



Application

This module is recommended for Pro-Series / Spraymaster sprayer installations, where a non-RDS control valve requires in excess of 2 amps to operate.



Contents

The kit contains the following components,

Item	Part Number	Description	Qty
1	S/AC/500-4-075	High Current Valve Drive Module	1
2	S/CB/500-1-022	5-amp Power lead	1
3	S/FIXING/079	1/4" Female Crimp Terminal	6
4	S/FX/199-2-129	Self-adhesive Cable Tie Base	2
5	S/CBL/TIE/001	Cable Tie	10
6	S/DC/500-10-514	Instruction Leaflet	1

Installation

- Although the module is waterproof, to avoid possible corrosion of the connections,
 - locate it where it will be shielded from corrosive chemical spray.
 - if possible apply a spray grease to the connections.
- Connect the standard Valve Drive Lead from the junction box/Terminator, to terminals 1 and 4 of the module.
- Connect the Power Lead from a suitable switched +V and 0V supply, to terminals 2 and 5 of the module.

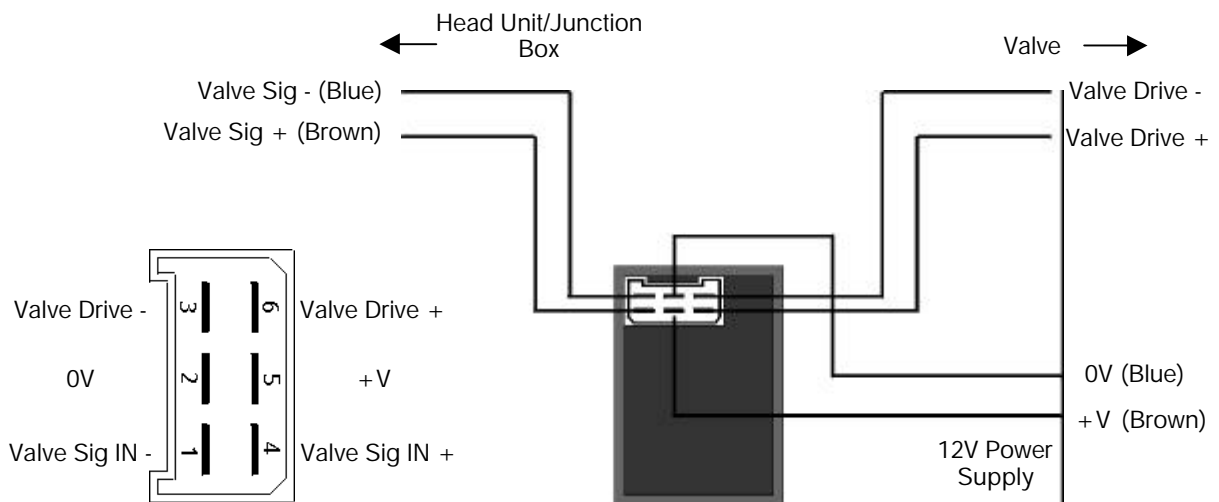

- Connect the Control Valve using a length of suitable cable (not supplied) to terminals 3 and 6 of the module.