

Electro-Magnetic Compatibility (EMC)

This product complies with Council Directive 89/336/EEC when installed and used in accordance with the relevant instructions.

Service and Technical Support

PLEASE CONTACT YOUR LOCAL DISTRIBUTOR

If unknown then fax: 44 (0) 1453 733311

© Copyright RDS Technology Ltd 2001

Our policy is one of continuous improvement and the information in this document is subject to change without notice. Check that the software reference matches that displayed by the instrument.

Document number

S/DC/500-10-255 : Issue 2 : 4/1/01

\\UK255-2.DTP



User Guide

Binmaster 8000 **Bin Weighing System** **Installation and Calibration**

Software Ref: PS305-002

Contents

Installation **3**

1.1	Strain Sensors	3
1.2	Angle Sensor	7
1.3	Head Unit and Wiring	8
	1.3.1 Mounting the Head Unit	- 8
	1.3.2 Mounting the Junction Box	- 8
	1.3.3 Connecting the Head Unit	- 8
	1.3.4 Connecting the Sensors	- 9
	1.3.5 Connecting the power supply	- 10
	1.3.6 Connecting a Printer	- 11
	1.3.7 Remote Enter Switch	- 12
	1.3.8 Weighing Sytem - Automatic Inhibition	- 12
1.4	Testing the system	13

Calibration **15**

2.1	Calibrating the angle sensor	15
2.2	Sensor setup	15
2.3	Weight calibration	19
	2.3.1 View Cal. Factors	- 20
	2.3.2 View Tare Factors	- 20
	2.3.3 Tare the system	- 21
2.4	Test Weighing	22
2.5	Alarms	22
2.6	Re-calibration using the NUDGE function	23
2.7	Stores Data	24
	2.7.1 Switch Product / Customer reference On/Off	- 24
	2.7.2 Edit Product / Customer reference	- 24
2.8	System Settings	25
	2.8.1 Printer setup	- 25
	2.8.2 Instrument ID	- 26
	2.8.3 Set PIN for "System Settings" menu	- 26
	2.8.4 Set language	- 27
	2.8.5 Reset factors	- 27
	2.8.6 Store / Restore / Print Cal. Data	- 27
	2.8.7 Switch "Driver Number" function On/Off	- 28

1.1 The Strain Sensors

IMPORTANT ! The installation involves welding. Before you commence welding, disconnect the vehicle battery by means of the battery isolator switch adjacent to the battery box.

Install the strain sensor before the other components. This will give the adhesive time to cure sufficiently before working the machine. The hydraulics should be fully relaxed e.g. the lift arms are resting just their own weight on the ground.

Position the sensor adjacent to each ram pivot. This part of the lift arm has the highest strain. Ideally, the sensor should operate in tension so it should be mounted in position 'A' on the rear face of the arm (fig. 3), however this may not be possible if;

- (a) the hydraulic pipes run up the rear face.
- (b) there is insufficient clearance between the ram body and the rear face when the arms are in the fully raised position.

The alternative position is position 'B' (fig.3) where the sensors will operate in compression.

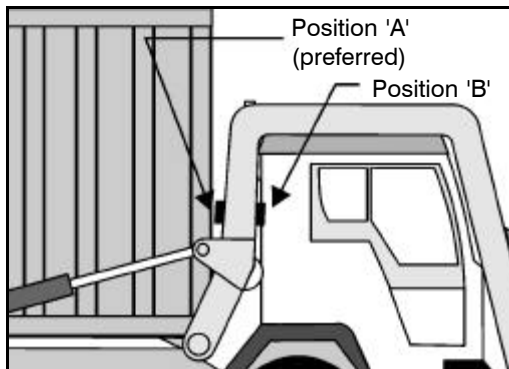

Figure 3 Strain sensor position

1. Measure 400 mm from the ram pivot point and mark across the face of the arm. Clean the area back to bare metal.
2. Bolt the Sensor Mounting Blocks onto the welding jig and clamp the assembly centrally over the mark (fig.4).

NOTE: IMPORTANT! The strain sensor is extremely sensitive to bending forces. Correct operation depends on it being bolted down to as flat a surface as possible, so take care to ensure that the welding jig, mounting blocks and surface of the box section are cleaned beforehand.

1 - Installation

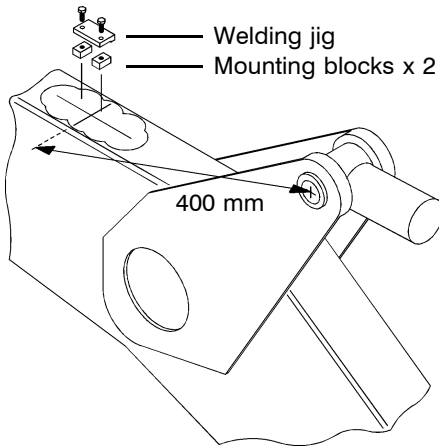

Figure 4 Fitting the Sensor Mounting Blocks

3. Weld the blocks with a continuous seam weld around the outer 3 sides of each block (fig. 5). Allow to cool fully before removing the welding jig to prevent the possibility of the mounting blocks warping.

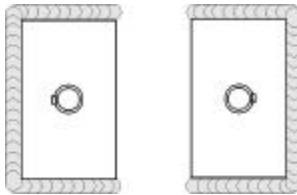

Figure 5 Weld position

4. Check the faces are flat using a suitable straight edge (e.g. a steel rule). In the event that the blocks have warped slightly, carefully file across both faces until they are flat and parallel. Mask the top face of the mounting blocks and around the mounting area, and make good with primer/top coat paint.
5. Check the mounting faces on the sensor are clean and flat. Use emery cloth if necessary and thoroughly degrease with proper solvent degreaser (not petrol or white spirit).

1 - Installation

6. Prepare the PERMABOND adhesive (1 pack per sensor) following the instructions on the rear of the pack and apply to the mounting faces (figs 6,7)



Figure 6

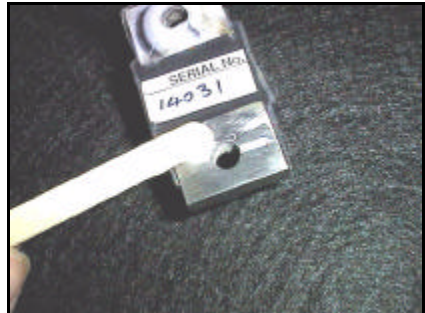

Figure 7

7. Degrease the mounting blocks and fasten the sensor using the M8 Socket Caphead screws supplied, with the cable facing back towards the lift arm pivot (fig. 8). Torque the screws to 35 Nm.

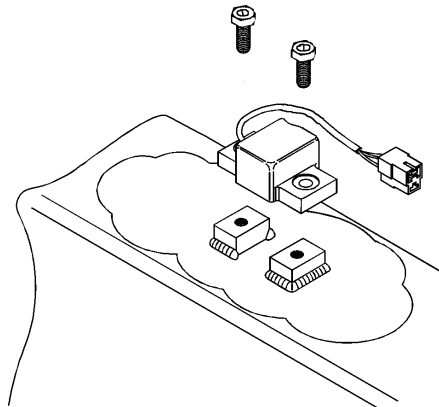

Figure 8 Mounting the sensor

NOTE: Avoid forcing the hex wrench against the sensor body. This will prevent large sensor offsets which may render the sensor inoperative.

The adhesive will set in only 3-5 minutes at 20°C - longer at lower temperatures. Full curing will take considerably longer. The lift arms should not be loaded for at least 1½ hours.

1 - Installation

- BOTH ARMS:** Position the sensor cover, mark through and drill and tap M6. Slip the heat shrink and conduit over the sensor cable (fig.9)...

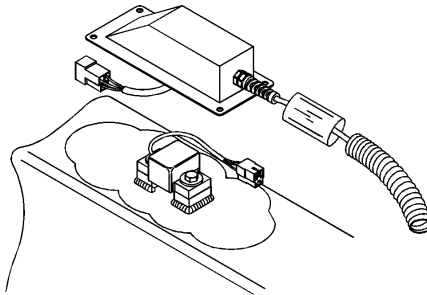

Figure 9

...then shrink together over the cable protection gland (fig. 10). Mate the 3-way connector using grease to protect against the possibility of any corrosion, and fit the sensor cover using rubber washers (or suitably sized rubber grommets) under the screw heads (fig. 13). Do not over tighten the screws.

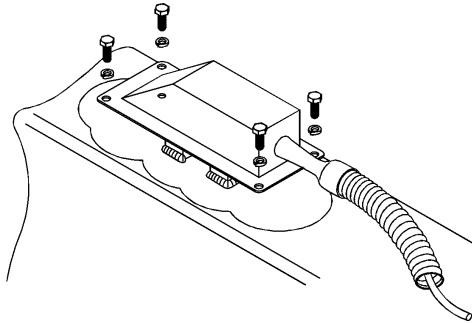

Figure 10

- Use 'P' clips fastened with POP Rivets, to fix the conduit securely back along the arm, following the hydraulic pipes back onto the vehicle body (fig. 11) to where the junction box will be mounted.

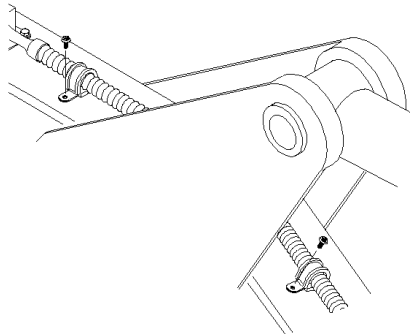

Figure 11

1.2 Angle Sensor

1. Lift the arms to the reference position. This is normally at the point where the cross bar is level with the top of the windscreen (fig.12).

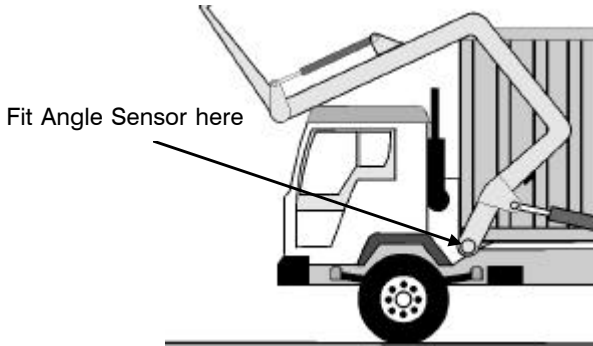

Figure 12 Weighing reference position

2. Fit the angle sensor on the centre of either_arm pivot (fig.12). **Rotate the sensor so that the cable gland on the sensor housing is horizontal and faces toward the rear of the vehicle.** The sensor won't work properly in any other position.
3. Drill and tap M6 through the centre of the slots on the sensor flange, to enable some angular adjustment in either direction if necessary.
4. Feed the sensor cable into the plastic conduit and route the conduit back along the hydraulic pipework/ wiring loom to where the junction box is to be mounted. Fasten the conduit to the side of the arm with 'P' clips as necessary.

NOTE: *On powering up the system you can check the power supply to the angle sensor. Simply remove the cover plate and when powered, a red LED will be visible through the potting compound.*

1 - Installation

1.3 Head Unit and Wiring

1.3.1 Mounting the Head unit

Confirm with the operator on where to mount the head unit in the cab. The head unit must not restrict the view out of the cab or the use of the controls.

The *Binmaster 8000* is supplied with a ball-jointed mounting stalk. Fit using the M8 screws nuts and washers provided in the kit.

1.3.2 Mounting the Junction Box



















All cable connections are made into this box. The junction box is sealed against moisture and dust. The cable glands all have removable blanking discs so that unused glands remain sealed.

Fit the junction box on the cab where it has some degree of protection from weather or physical damage, and where the various cables can be conveniently fed through. The actual position depends on the particular vehicle. In some cases you may be able to fit it behind the front grille.

1.3.3 Connecting the Head Unit

Route the 12-core cable from the 50-way 'D' connector on the head unit back to the junction box, and cut to length to suit the installation.

Connect the wires to their respective terminals 1 -12. Refer to the wiring label on the inside of the junction box lid.

LM 8000 WIRING CONNECTIONS <small>Branchement des câbles LM 8000 / LM 8000 Kabelverbindung / LM 8000 Bedrading</small>				
Terminal No.	S/CB/268-2-005		S/CB/268-1-011	S/CB/268-1-012
Numéro sur PCB Terminal Nr. Terminal No.	Black-sheath - 12 core Gaine noire - 12 fils Schwarz Umhüllt - 12 Kabel Zwart Omhuls. - 12 draden	Grey-sheath - 12 core Gaine grise - 12 fils Grau Umhüllt - 12 Kabel Grijs Omhuls. - 12 draden	Grey-sheath - 40 core Gaine grise - 40 fils Grau Umhüllt - 40 Kabel Grijs Omhuls. - 40 draden	Universal - 40 core Universel - 40 fils Universell - 40 Kabel Universeel - 40 draden
1	Brown Marron Braun Bruin 			White-Black-Black 
2	Turquoise 	Tan Bronze Ocker Geelbruin 		
3	Pink Rose Pink Roze 		Red-Black 	
4	Yellow Jaune Gelb Geel 			
5	Orange Orange Orange Oranje 			
6	Blue Bleu Blau Blauw 			
7	Red Rouge Rot Rood 			
8	Black Noire Schwarz Zwart 			
9	Violet Violet Violet Violet 			
10	Grey Gris Grau Grijs 		Red-Yellow 	
11	White Blanc Weiß Wit 			White-Red-Red 
12	Green Vert Grün Groen 		White-Red 	White 

2786-225

Figure 13 Head Unit connections

1.3.4 Connecting the Sensors

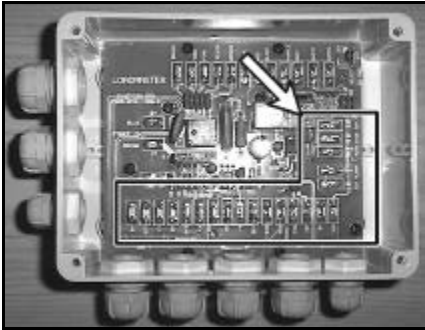

Figure 14 Terminals for connecting the sensors

1. Connect the left-hand strain sensor to the terminals marked 'PRESSURE SENSOR 1'

Terminal	Wire Colour
+V	Brown
0V	Blue
SIG	Green/Yellow

2. Connect the right-hand strain sensor to the terminals marked 'PRESSURE SENSOR 2'

Terminal	Wire Colour
+V	Brown
0V	Blue
SIG	Green/Yellow

3. Connect the Angle sensor to the terminals marked 'ACCELERATION'

Terminal	Wire Colour
+V	Brown
0V	Blue
ACC	Green/Yellow

4. Connect the PTO input to the 'DIR' terminal.

It is recommended that you clearly identify the strain sensor cables 'LEFT' and 'RIGHT' inside the junction box, in the event you need to replace a sensor.

1 - Installation

1.3.5 Connecting the Power Supply

Requires Kit Ref: K/24V-13.8/CON/KIT

The head unit can operate in the voltage range 10 - 30V however, the strain sensors require a minimum 12.2V. Whereas the head unit is switched on and off from the front panel, the strain sensors must be permanently powered in order to maintain their correct operational performance.

A power supply loom with an in-line fuseholder is provided and is suitable for any installation.

Connect to the the Power supply

The power supply loom (see below) includes a 24V - 13.8V voltage dropper. Connect the power supply from a suitable permanently live point - e.g. from the fusebox.

Locate the voltage dropper where it is protected from the elements, e.g. within the vehicle cabin.

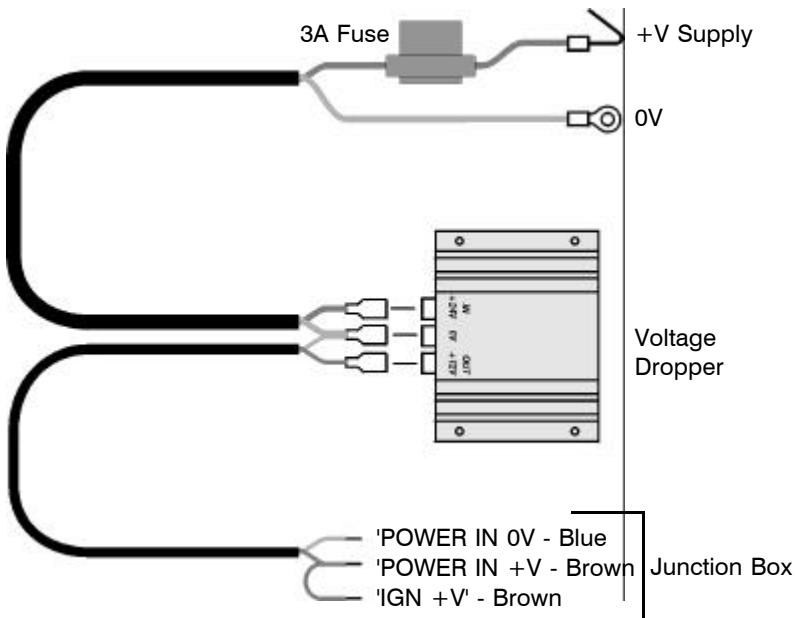

NOTE: The junction box PCB has a jumper switch to select the voltage. Check that this is set to the 12v position.

Connection to Voltage Dropper

Connect the brown wire of the thicker cable to the '24V IN' terminal.
Connect the blue wire to the '0V' terminal.
Connect the brown wire of the thinner cable to the '12V OUT' terminal.

Connection to the junction box

Feed the cable through one of the cable glands and fit the crimp terminals,
Connect the brown wire to the 'POWER IN +V BROWN' terminal.
Connect the blue wire to the 'POWER IN 0V BLUE' terminal.
Connect the brown jump wire to the 'IGN +V' terminal in the junction box
(this wire permanently powers the strain sensors).

NOTE: *If the head unit system must be turned off with the ignition, then instead of connecting the jump wire to 'IGN +V', connect it across from the 'POWER IN +V BROWN' to the +V terminal of 'PRESSURE SENSOR 1' and 'PRESSURE SENSOR 2'. Only the strain sensors are then permanently powered.*

1.3.6 Connecting a Printer

ICP100 Printer

The power supply for an ICP100 printer can be 12V or 24V and should be powered separately i.e. not from the junction box.

ICP200 Printer

The ICP200 printer is powered through the printer cable connected to the head unit.

1 - Installation

1.3.7 Remote Enter Switch

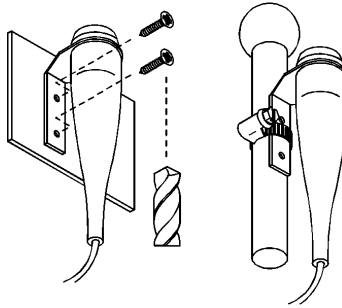

This is optional, replacing the use of the ENTER key on the head unit to manually enter the weight reading.

Mount where most convenient for the operator. Route the cable back to the junction box. The terminals are clearly marked 'REMOTE ENTER' .

Blue = 0v

Brown = +v

1.3.8 Weighing system - Automatic inhibition

Due to the arms being close to the reference position while the vehicle is in transit and because the weighing system is 'live', extraneous weight readings may occur while the vehicle is moving, unless the head unit is switched off.

Weighing can be automatically inhibited by for example, detecting when the PTO hydraulic pump is disengaged (as is normal when on the road).

To enable this, first trace the wire from the *switched* (+V) side of the PTO indicator lamp back to a suitable point where you can connect into it.

Connect a single wire from the 'DIR' terminal in the junction box and using a Scotchlock connector, connect the other end into the indicator lamp wire. The cutout input will then be pulled down to 0V when the light goes out.

NOTE 1: *The head unit can only sense a 'pull down' input for the cutout i.e. going to ground when the PTO is disengaged. If the switching situation is from 0v to +v, an automotive relay (not supplied) should be used to provide a ground signal.*

NOTE 2: *'0v' and 'Ground' are not the same thing. '0v' indicates precisely what it is and it may not necessarily be grounded. The input will only work when it is grounded.*

1.4 Testing the System

NOTE: Do not load the arms for at least 1½ hours after glueing the sensors.

1. From the SETUP page, select 'Diagnostics' from the Setup menu (fig.15).



Figure 15 THE 'Diagnostics' screen

This screen page displays an indicator bar showing the weighing status. As you lift the arms, the frequency output and weigh sample time for weighing up and weighing down will be displayed for each sensor.

NOTE: The weighing sequence may not work correctly until the angle sensor is calibrated.





2. Press  to display the strain sensor inputs (fig.16).



Figure 16 Strain sensor input screen

You should see a live frequency output of around 2.0 kHz for a no-load condition. This can change when the sensors are bolted down due to torsion.

The   indicators open and close to indicate frequency output.

 shows the PTO On/Off input status (closed means pulled down to ground).

1 - Installation

If a sensor is not working then the frequency display will show 0.0Hz and on the MAIN screen, the error message 'Sensor A Error' or 'Sensor B Error' will be displayed after weighing up.



indicates the status of the Remote Enter Switch (optional).

3. Press ESC to return to the 'Diagnostics' screen and then press  to display the Voltage Input screen.

The angle sensor input should display around 2.5v increasing as the arms are raised and decreasing as they are lowered. The figure indicates that the sensor is functioning, although is meaningless unless the sensor is calibrated.

4. The supply voltage should be above 12.2v in order for the strain sensors to function correctly. On a 24v system fitted with the voltage dropper, the nominal voltage should normally be a regulated 13.8v.

NOTE: *Ignore the Sensor voltage displayed on this screen.*

5. If the above checks indicate any problem, check the following before assuming that a sensor is faulty;
 - Wiring connections in the junction box.
 - Power supply lead and fuses
 - In-line connectors on the sensor leads.
6. Before calibrating the system, you must work the lift arms under load (e.g. an empty bin) to bed-in the strain sensors. Select the 'Diagnostics' screen and repeatedly lift for 15 minutes. There may be an initial frequency drift as the sensors bed-in. When the frequency settles around a constant figure, the system is then ready to calibrate.

2- Calibration

For easy navigation to any of the calibration functions, a menu diagram is also included at the back of this manual. On installation, calibrate in the sequence given on the following pages.

The default PIN is 1234. The PIN can be changed if desired, to prevent inadvertent or undesirable changes to important calibration settings. If you do change the PIN, remember to note down the personalised number for future reference.

2.1 *Calibrating the Angle Sensor*

1. Select the AUTOCAL function;

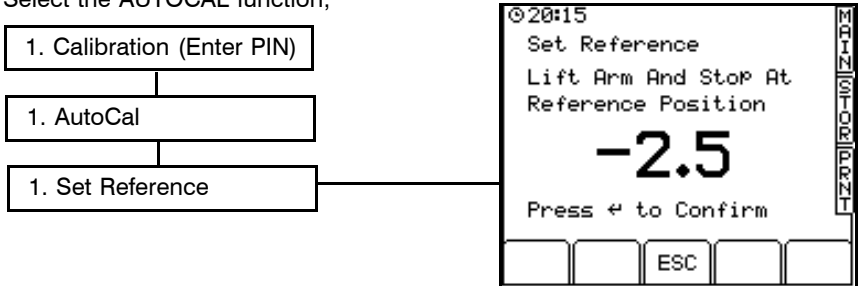

2. Lift the arms to the intended reference position and press ENTER to confirm. This sets the 'Trigger Angle'. The sensor is then calibrated.

2.2 *Sensor Setup - screen 1*

1. Select the SENSOR SETUP screen;

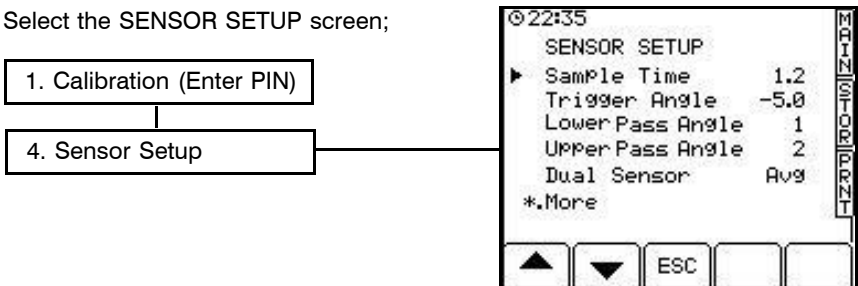

'Sample Time'

The period during the lift over which weight measurement occurs. The weight is averaged from both sensors.

2 - Calibration

Because the sample period is time-based, the actual angle through which the arms are raised will vary according to the speed of lift. A slower lift will result in weight sampling over a smaller angular displacement and vice versa. The system is fully speed-compensating with no speed calibration necessary.

The default value (1.2 sec) should not normally need to be altered.

'Trigger angle'

This is automatically set when you calibrate the Angle sensor. The sensor output voltage range is,

90° CW	4v
LEVEL	2.5v
90° CCW	1v

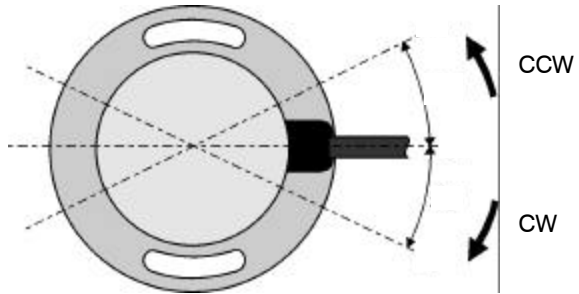

...so in the reference position, the trigger angle should normally be around 0° with 2.5v output on the diagnostic screen.

Upper and Lower Pass Angle

The upper pass angle is the angle of movement of the lift arm beyond the angle of the arm at the end of the Weigh-up sample period. It sets the point when the instrument prompts you to 'Lower Bin'.

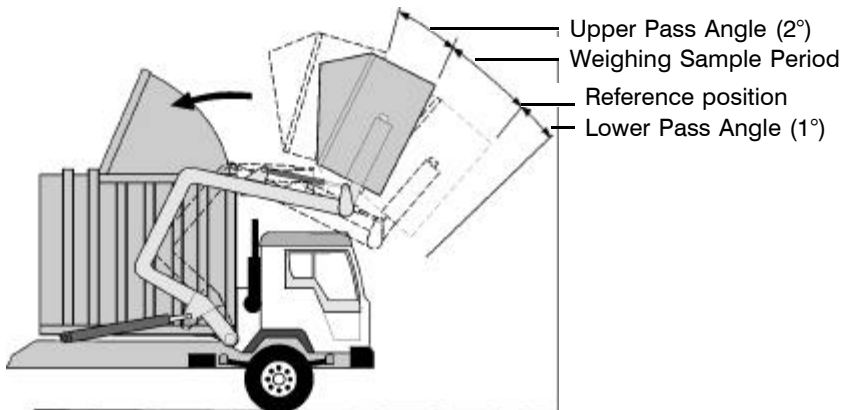

2 - Calibration

Likewise, the lower pass angle is the angle of movement below the reference position. It sets the point when the instrument logs the net weight and prompts you to enter the next **'Customer reference Number'**, (or if this option is disabled it will prompt **'Raise Bin'**).

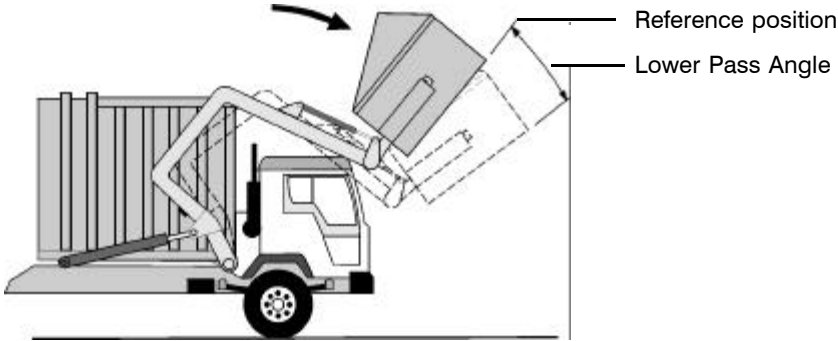

'Dual Sensor'

This sets the method by which the instrument combines the two sensor readings.

Default = 'Avg' Do not change this setting.

Sensor Setup - screen 2

Press **'* more'** to display more functions.

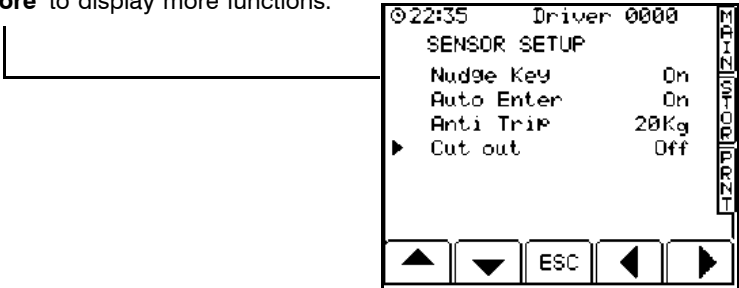

2 - Calibration

'Nudge Key'

Enables/disables the NUDGE function on the SETUP screen.

Default = 'On'

'Auto Enter'

Sets whether the weight is automatically recorded as the bin is lowered, or the ENTER key (or Remote Enter Switch if fitted) is pressed to confirm the weight entry.

Default = 'On'

'Anti Trip'

The weighing system is normally powered on from the ignition circuit and therefore will remain 'live' unless you switch the head unit off via the on-off button. This setting prevents the weighing system from triggering while the vehicle is en-route, e.g. as a result of going over bumps etc.

Default = 20kg

This setting should be adequate in normal use but may be increased if spurious weight readings occur en-route. Alternatively, you can enable the 'cutout' function (see below) to automatically inhibit weighing if the PTO is disengaged.

'Cutout'

Off :- the weighing system remains 'live' unless switched off at the head unit or via the ignition (see 'Anti-trip' above).

Set to  to enable the cutout input wired via the PTO warning light.

Set to  to enable the cutout input obtained by other means e.g. via a pneumatic pressure switch (default setting).

NOTE: *The status of this input is indicated on the top of the screen pages by the  icon.*

 means the PTO is disengaged.

 means the PTO is engaged.

The absence of the icon means that the cutout is set to 'Off'.

2.3 Weight Calibration

The system can be calibrated separately for up to 8 different bin types A to H. Keep a record of the type of bins below.

A	
B	
C	
D	
E	
F	
G	
H	

1. Select the AUTOCAL function;

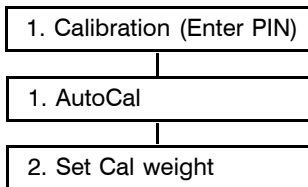



2. Select the bin type that you wish to calibrate. Press  repeatedly if necessary, to cycle through bin types A to H.
3. Lift and lower the empty arms. Key-in zero for the 'Empty Bin Weight' and press ENTER. This sets the tare. The message 'Lift Full Bin' is then displayed.
4. Lift and lower a full bin of the appropriate type. Key-in the bin weight and press ENTER. Initial weight calibration is now complete. The Cal. factors are now stored.

2 - Calibration

2.3.1 To view the Cal Factors

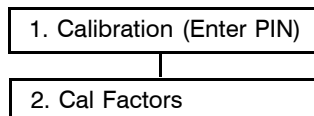
From the SETUP screen, select;



Press  repeatedly if necessary, to cycle through the cal figures for bin types A to H.

2.3.2 To view the Tare Factors

From the SETUP screen, select;

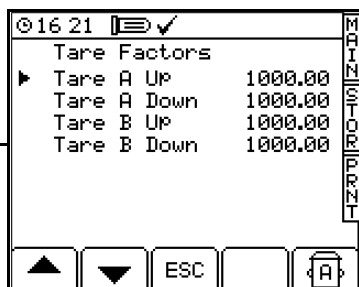
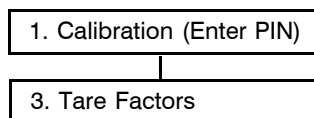

The figures are actually the generated frequency for each sensor tare.

Press  repeatedly if necessary, to cycle through the figures for bin types A to H.

2 - Calibration

2.3.3 To tare the system

After initial installation and weight calibration, it only becomes necessary to re-tare the system if there is some change made to the machine for example, replacing components due to wear, welding repairs or any other modifications.

- 1. From the SETUP screen press  to select the tare screen.



- 2. Lift and lower the arms and follow the screen prompts to confirm the tare.
- 3. Select the next bin type and repeat the tare procedure for bin types A through H.

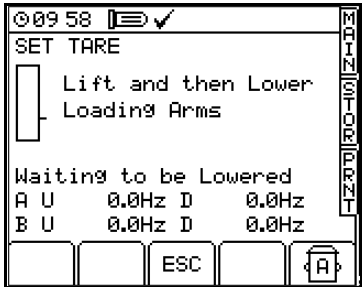

2 - Calibration

2.4 Test weighing

The TEST function in the diagnostics screen is useful for displaying the 'weigh-up' weight and the 'weigh-down' weight without having to empty the contents of a bin.

1. Tare the system with no bin attached (section 2.3.3).
2. Select the 'Diagnostics' screen and press the TEST key.
3. Lift and lower the bin as normal.
4. The weights are then displayed.

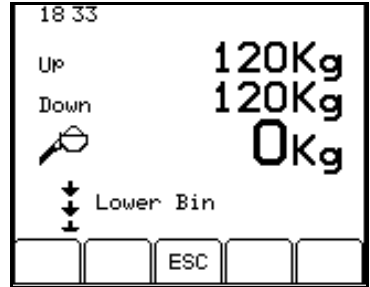

NOTE: It is recommended that a re-tare is done before doing the above procedure (ref. section 2.3.3).

2.5 Alarms

There are two alarms. The Load Alarm will trigger when the accumulated weight reaches a programmed threshold.

The Bin Alarm will trigger if the bin weight is above a pre-programmed threshold.

From the SETUP screen, select;

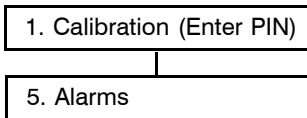



Key-in the weight threshold for each alarm and press ENTER. The bin alarm threshold should not be set above the safe working load for the lifting arms.



NOTE: A zero weight (the factory default setting) disables an alarm function.

2.6 Re-calibration using the "NUDGE" function

A consistent discrepancy between the instrument weight total and the load recorded over the weighbridge is easily rectified.

1. Make a note of the weighbridge total and the instrument total.
2. Press  and then the  key to select the "NUDGE" screen (below).



3. Press  to select the bin type.
4. Enter the instrument total () and press ENTER.
5. Enter the weighbridge total () and press ENTER.

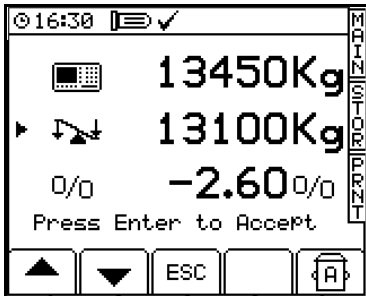

6. The percentage difference between the two figures is then displayed. Press ENTER to accept and the new calibration factors are then stored in memory.
7. Press the MAIN menu key to return to the weighing screen.

2 - Calibration

2.7 Stores Data

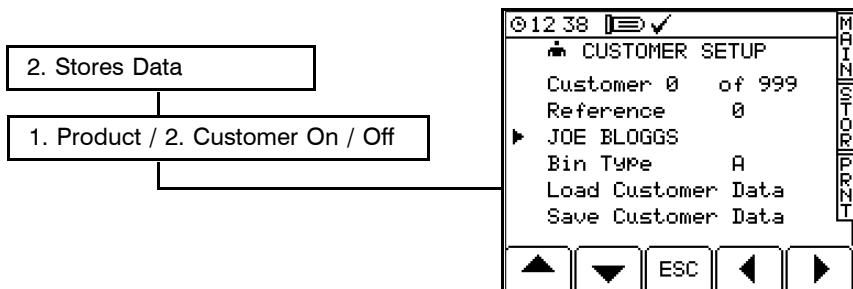

2.7.1 Switch Product / Customer Reference On/Off

If you do not want to have to enter the customer reference each time before you can weigh, then you can switch this function off (as well as switching the product reference on or off).

From the SETUP screen, select '2. Stores Data' to reach the STORE SETUP screen. Select either the 'Product' or 'Customer' line using the arrow keys and then press  to switch either on or off.

2.7.2 Edit Product / Customer Reference

You can edit the Product or Customer description for any of the 200 product stores or 1000 customer stores.

Select the 'Product' or 'Customer' line using the arrow keys and then press the right arrow key to move the cursor ready to edit the line. Enter the text using the alpha-numeric keypad.

2.7.3 Edit Bin type

You can select the bin type A to H for individual stores. When you subsequently select the customer reference before weighing, the system will use specific weight calibration figures for the bin type associated with the customer (or product) store selected. You must ensure however that the instrument has been calibrated separately for each bin type selected.

2.7.4 Upload / Download Data

You may also upload or download Product and/or Customer data for all the stores from this screen with an optional data upload/download kit. For instructions on uploading or downloading from a PC to the head unit, please refer to the separate "Upload/Download Data" manual from RDS.

2.8 System Settings

2.8.1 Printer Setup

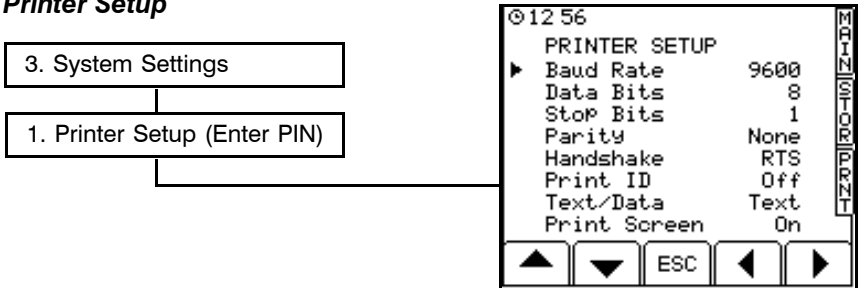

The default settings (in bold below) are for an RDS ICP200 In-Cab Printer. You can alter the setting to suit other types of printer. Please refer to the manual supplied with the printer.

The options are as follows;

Baud rate: 110 / 150 / 300 / 600 / 1200 / 2400 / **4800** / 9600 / 19,200 / 31,250 or 38,400.

Data Bits: 7 / **8**

Stop Bits: **1** / 2

Parity: **None** / Odd / Even

Handshake: **RTS** / XON

Settings for an ICP100 printer must be:- 4800 Baud, 7 Data Bits, 2 Stop Bits, No Parity, RTS Handshake.

"**Print ID**" enables an instrument ID - a line of text to be included in any printout.

"**Text/Data**" selects the data output format:

TEXT: - Automatically outputting ASCII text to an ICP100 or ICP200 printer

DATA:- Comma-delimited output for importing into a database program.

CARD:- Automatically outputting a .CSV file to the RDS Data Module.

NOTE 1: Ignore the setting 'Print Screen'.

2.8.4 Set Language

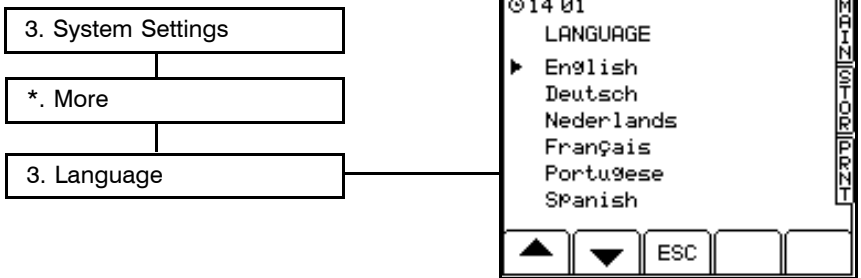

Position the menu pointer to the desired language and press ENTER.

2.8.5 Reset Factors

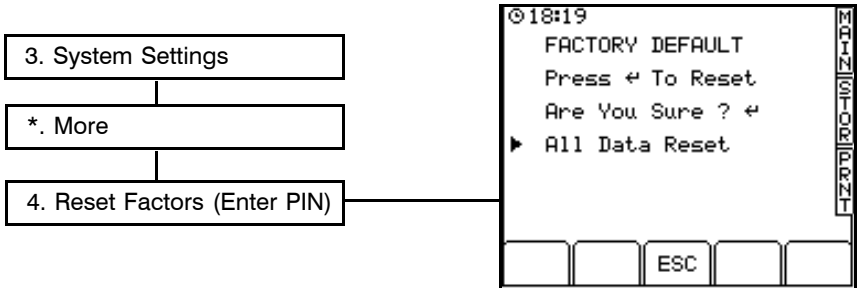

Follow the screen prompts to reset the instrument to the factory default settings.

NOTE: *All customised factors and other data will be lost. Keep a record of the existing calibration data.*

2.8.6 Store / Restore / Print Calibration Data

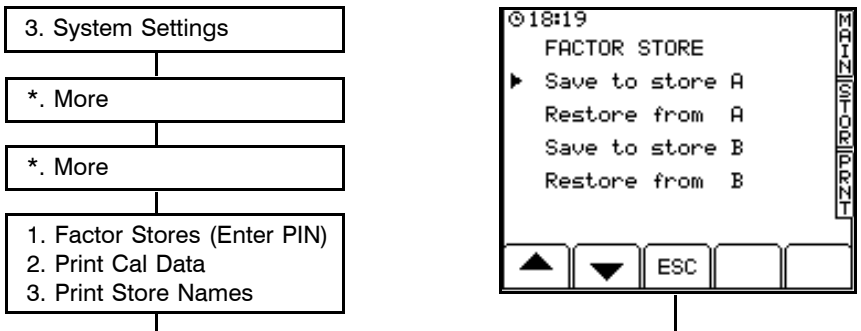

2 - Calibration

1. 'Factor Stores'

Each time the instrument is powered down all current factors are AUTOMATICALLY recorded to store A, overwriting the previous data. The calibration data can also be recorded to a second store B which is never automatically overwritten. This enables the original calibration data to be kept secure, and restored at any time.

2. 'Print Cal Data'

Press ENTER to print out the calibration data.

3. 'Print Store Names'

Press ENTER to print out a list (a very long list!) of all the store names.

2.8.7 Switch "Driver Number" function On / Off

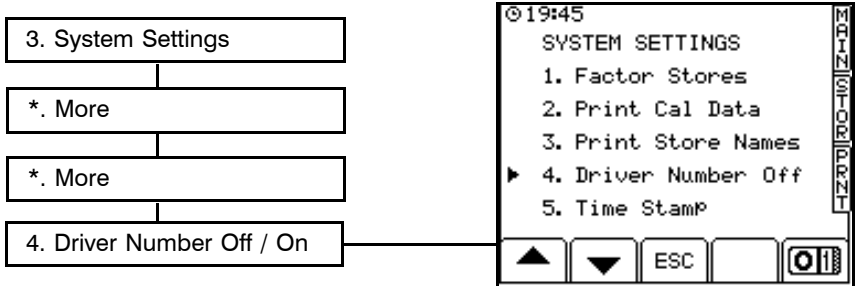

If you do not want the "ENTER DRIVER NUMBER" screen to appear each time the instrument is switched on, then switch this function off using the  key.

2.8.8 Switch "Time Stamp" function On / Off

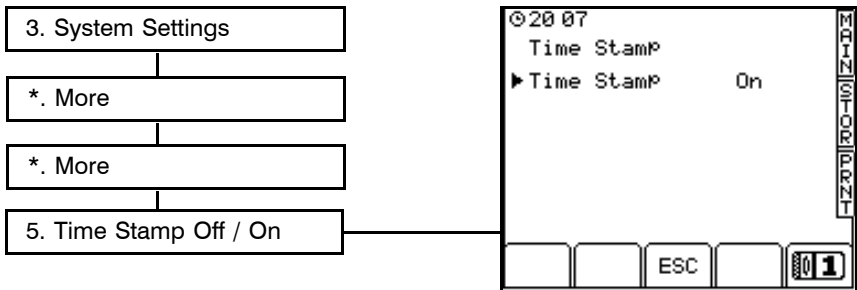

If you do not want the time to appear on every printout, then switch this function off using the  key. Only the date will be printed.

Notes
