

Electro-Magnetic Compatibility (EMC)
This product complies with Council Directive
89/336/EEC when installed and used in accordance
with the relevant instructions.



Service and Technical Support
PLEASE CONTACT YOUR NEAREST DISTRIBUTOR
If unknown then fax: 44 (0) 1453 733322

© Copyright RDS Technology Ltd 2001

Document number
S/DC/500-10-310 : Issue 1 : 4/7/01

\\UK310-1.DOC

User Guide

Artemis 100 **Variable Rate Drill Controller**

Calibration and Operation
Software Reference A500.000 rev. 7

Contents

| | |
|--|-----------|
| Overview | 4 |
| Operating Summary | 5 |
| Power On/Off..... | 5 |
| Switch Functions..... | 5 |
| Normal Display Mode | 6 |
| Programming Modes..... | 6 |
| Work Status Indicator | 6 |
| A Forward Speed Display | 7 |
| A.1 View Forward Speed | 7 |
| A.2 Speed Alarms | 7 |
| A.3 Speed Sensor Calibration..... | 7 |
| Manual Calibration | 8 |
| Auto Calibration | 9 |
| B Area Display | 10 |
| B.1 View Area Totals | 10 |
| B.2 Zero Area Total..... | 10 |
| B.3 Set Implement Width | 11 |
| C. Drilling Rate Functions | 12 |
| C.1 View Drilling Rate | 12 |
| C.2 Adjusting the Drilling Rate..... | 12 |
| C.3 Drilling Rate Indicator | 12 |
| C.4 Changing the Target Rate | 13 |
| C.5 Set Current Rate to become new Target Rate | 13 |
| C.6 Product Calibration | 14 |
| C.7 Set "Thousand Grain Weight"..... | 15 |
| C.8 Select Unit | 16 |
| C.9 Set % Step for Rate Offset..... | 16 |
| C.10 Frequently asked Questions | 17 |

| | | |
|-----------|---|-----------|
| D. | <i>Fan Speed Display</i> | 18 |
| D.1 | View Fan Speed..... | 18 |
| D.2 | Fan Under-Speed Alarm | 18 |
| D.3 | Fan Over-speed Alarm | 18 |
| D.4 | Set Low Fan Speed Alarm..... | 19 |
| E. | <i>Tramlining</i> | 20 |
| E.1 | Manually advance bout number | 20 |
| E.2 | Hold Bout number | 20 |
| E.3 | Symmetrical Tramlining | 21 |
| E 4.1 | Asymmetrical Left Tramlining | 22 |
| E 4.2 | Asymmetrical Right Tramlining..... | 23 |
| E 4.3 | 10-bout Tramlining | 24 |
| E 4.4 | 18-bout Tramlining..... | 25 |
| E.5 | Programme Tramline Bout | 26 |
| F. | <i>Hopper level Alarm</i> | 28 |
| G. | <i>Programme Functions and Fault Diagnosis</i> | 29 |
| G.1 | Programme Modes 1 –4..... | 29 |
| G.2 | Error Codes..... | 30 |
| G2.1 | <i>Alarms irrespective of "Work" Status</i> | 30 |
| G.2.2 | <i>Alarms when the drill is in work</i> | 31 |

Overview

The *Artemis 100* Drill Control is a CAN Bus control system suited for both conventional and pneumatic drills. The system has two CAN Modules - one for controlling the electric motor driving the metering unit, and another controlling the various sensor inputs and tramlining outputs. All the components are connected via a custom wiring loom. The cab instrument has a 6-way Amphenol sealed connector allowing it to be easily disconnected and transferred to another drill as required. A separate heavy duty power cable powers the CAN Modules and motor. An in-line heavy duty, quick-release connector simplifies mounting and dismounting the drill.

The metering unit is controlled via an electric motor, allowing the drilling rate to be varied at the touch of a button. The drilling rate can be varied in 5% or greater steps from the pre-programmed target rate.

The instrument measures and indicates;

- Forward Speed
- Part Area and Total Area worked
- Tramline bouts
- Seed Application Rate (kg/ha or Seed/m²)
- Fan Speed
- Low Hopper Level

The instrument has a number of alarm functions for fan over-speed, forward over-speed and under-speed, and hopper level. In addition, a number of extra alarms are displayed as fault codes.

The instrument must be initially calibrated to suit the implement being controlled. Seed calibration is very simple to undertake via a priming switch provided on the drill. Other default settings are also programmable in the calibration mode.

Area totals and all calibration data are automatically stored in memory when the instrument is powered off.

Operating Summary

Power On/Off

Switch the system on/off via the toggle switch on the rear of the head unit.

Switch Functions

Current Bout

At Target rate Indicator

Channel Indicator

Decrease Rate

Increase Rate

Preset Tramlining bout Indicator

Press to select the Display Function

Increase Rate Or, HOLD whilst powering on to enter CAL Mode 2 (for automatic product calibration)

EITHER:

- 1. View Area Total**
Select the channel then press to switch between Area Total 1 and Area Total
- 2. Advance Bout Number**
Select the channel then press to manually advance the Bout Number.
- 3. Set Target Rate**
Select the channel then press and hold to display rate. Use +RATE and -RATE to adjust.
- 4. HOLD continuously** to enter Programme mode 1 / Programme Mode 2 (Normal Mode is resumed when the button is released).

| CH | Function | Units |
|----|-----------------------|-------------------------------|
| 1 | Forward Speed | km/h |
| 2 | Area Total 1 or 2 | ha |
| 3 | Tramline/Current bout | - |
| 4 | Seed Rate | kg/ha or seeds/m ² |
| 5 | Fan Speed | rpm |
| 6 | Hopper level alarm | 'lo.1, lo.2' |

These channels perform different functions when the instrument is set in to Programme Modes 1, 2, 3, or 4

Normal Display Mode

The instrument has a normal display mode displaying six work functions

Select a channel by pressing the  button once or more.

When the drill is in work, the selected channel is displayed for 10 seconds before defaulting back to the tramline bout display ( channel).

When the drill is out of work, the instrument will continue to display the selected channel.

Programming Modes

There are 4 programming modes with various calibration factors and default settings.

Access to the programming modes is required for some settings which are changed as part of the normal operating procedure (such as product calibration). Changing these settings is described within the normal operating instructions (sections A, B, C, C, D, E and F).

Other settings are made on installation and do not normally need to be changed unless the instrument is switched onto a different drill. These settings are appended to in the back of this manual (section G). The operator does not normally need to refer to them.

Work Status Indicator

The  indicator is used to indicate the channel to which the information on the display relates.

It also shows the working status of the drill. If the cursor is flashing then the drill is out of work, if the cursor is solid then the drill is in work.

A Forward Speed Display

A.1 View Forward Speed



The forward speed is derived either from an encoder on the landwheel, or from a radar sensor depending on your particular installation. The speed is displayed in km/hr only.



Figure 1 : Select Fwd. Speed

A.2 Speed Alarms

- (i) *If you stop with the drill still in work, the instrument will beep twice, and the display alternates between the selected channel and the forward speed channel, until you start moving again.*
- (ii) *If you drive too fast, the motor control will be unable to maintain the required seed rate. Again, the instrument will default to the speed channel, the display will flash "HIGH" and the instrument will beep until you slow down. The maximum forward speed is calculated by the software for the seed rate being achieved.*

A.3 Speed Sensor Calibration

The forward speed is derived from the distance travelled in millimetres for each pulse received from the speed sensor. The speed sensor is either a rotary encoder on the landwheel, or a radar sensor.

You can either calculate and manually enter the Speed Sensor Factor (S.S.F.) or do an "Autocal".

Manual Calibration

If a rotary encoder is fitted, the theoretical calibration figure equals the rolling circumference of the land wheel in millimetres divided by the pulses per rev. of the encoder,

$$\text{e.g. } \frac{\text{diameter (mm)} \times 3.142}{360}$$

The cal factor should normally be a figure around 10 (mm/pulse).

If a radar sensor is fitted, then accept the default factor of 7.78 mm/pulse for the RDS radar sensor.

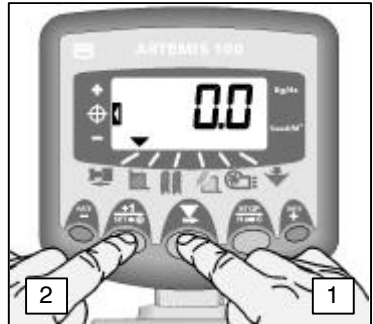

Figure 2 : Enter CAL Mode 1 (S.S.F.)

To manually enter the calibration factor:

1. Select the forward speed channel (fig. 2).
2. Press and hold the $\frac{+1}{\text{SET}}$ button until the cal factor appears on the display (fig 2).
3. Continue holding the $\frac{+1}{\text{SET}}$ button and PRESS \blacktriangledown to select the digit/decimal point to change (fig. 3).
4. HOLD \blacktriangledown to change the digit (or move the decimal point). Releasing the button selects the next digit.
5. Release the $\frac{+1}{\text{SET}}$ button to return to the normal display mode.



Figure 3 : Change S.S.F.

Failure to correctly programme the speed sensor factor will result in the drilling rate being displayed incorrectly. Auto calibration is likely to be more accurate than manual calibration.

Auto Calibration

Auto-calibrate in field conditions for maximum accuracy.

1. Place two markers 100 metres apart and position some reference point on the tractor (e.g. the cab step), opposite the first marker.
2. Select the forward speed channel.
3. Press and hold the $\frac{+1}{\text{SET} \rightarrow \oplus}$ button until the cal factor appears on the display.
4. Continue holding the $\frac{+1}{\text{SET} \rightarrow \oplus}$ button and press the $\frac{\text{STOP}}{\text{Halt} \rightarrow \ominus}$ button. The display will show "AUto" ready to start the test run (fig. 4).
5. Drive up to the second marker and stop exactly opposite the marker. The instrument counts and displays the pulses received from the speed sensor over the measured distance.

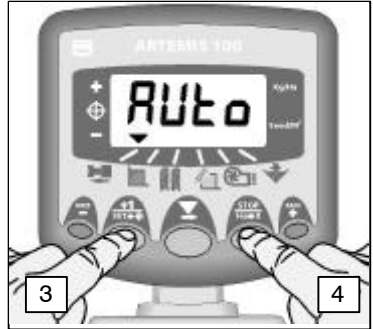
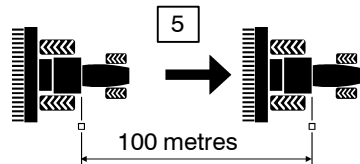

Figure 4 : Start AutoCal



NOTE: The instrument only displays up to 9999 pulses then cycles back to 0000, however the pulses are still being counted internally.

6. Press the $\frac{\text{STOP}}{\text{Halt} \rightarrow \ominus}$ button (fig. 5). The calibration factor is automatically calculated and stored in memory. The instrument then returns to the normal display mode.

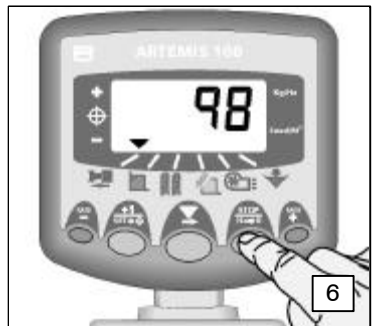

Figure 5 : Stop Autocal

B Area Display

B.1 View Area Totals



The area display is derived from the forward speed sensor and the programmed implement width.

There are two area registers. Each can be independently reset to zero.

Press $\frac{+1}{\text{SET} \rightarrow \oplus}$ to cycle between the two area registers 'tot.1' and 'tot.2'.

The display then shows the area accumulated since that total was last reset.



Figure 6 : Select Area Channel

B.2 Zero Area Total

1. Select the total 1 or total 2 and release.
2. HOLD $\frac{\text{STOP}}{\text{Ha} \rightarrow 0}$ for 5 seconds.



Figure 7 : Select Area Register 1 / 2

The instrument gives 10 beeps, then the total resets to zero.



Figure 8 : Zero Area Total

B.3 Set Implement Width



1. Select the Area Total channel ().
2. Press and hold the $\frac{+1}{\text{SET} \rightarrow \oplus}$ button for 5 seconds. The display will flash "tot.1", then "tot.2" then show the programmed implement width (fig. 9). Default width = 4 metres.
3. Continue holding the $\frac{+1}{\text{SET} \rightarrow \oplus}$ button and PRESS  to select the digit/decimal point to change.
4. HOLD  to change the digit (or move the decimal point). Releasing the button selects the next digit (fig. 10).
5. Release the $\frac{+1}{\text{SET} \rightarrow \oplus}$ button to return to the normal display mode.



Figure 9 : View Implement Width



Figure 10 : Change Implement Width

C. Drilling Rate Functions

C.1 View Drilling Rate



This channel displays the current drilling rate in either Kg/Ha or Seeds/m², depending upon the selection made at the beginning of the calibration routine.

The resolution for Kg/Ha units is:

0 to 24.9 0.1 Kg

25 to 250 1 Kg

250 to 9995 5 Kg

The resolution for Seeds/m² is 1 Seeds/m²



Figure 11 View Drilling Rate (kg/ha)

C.2 Adjusting the Drilling Rate

Press the **RATE**  button to decrease the drilling rate.

Press the **RATE**  button to increase the drilling rate.

The rate adjusts by the % step programmed in programme mode 3, i.e. 5%, 10%, 15%, 20% or 25% of the programmed target or base drilling rate.

Pos. 1



Pos. 2



Pos. 3



C.3 Drilling Rate Indicator

The left indicator is used to remind the operator of his drilling rate. When the indicator is in position 2, then the drill is operating at the target rate.

If the indicator is in position 1 then the drill is operating at plus the target rate.

If the indicator is in position 3 then the drill is operating at minus the target rate.

C.4 Changing the Target Rate

If the drilling rate is currently at the target rate (the rate indicator is in position 2), then:-

1. With the rate display selected, press and hold the $\frac{+1}{\text{SET} \rightarrow \oplus}$ button for 5 seconds (fig. 12).

The display will initially show either the top row of segments or the bottom row of segments to indicate the currently selected units, then the current target rate.



Figure 12 View current Target Rate

2. When the number is flashing, release the $\frac{+1}{\text{SET} \rightarrow \oplus}$ button.

3. Press and hold either the $\frac{\text{RATE}}{+}$ button to increase the target rate, or the $\frac{\text{RATE}}{-}$ button to decrease the target rate (fig. 13). The longer the switch is held, the faster the number changes.

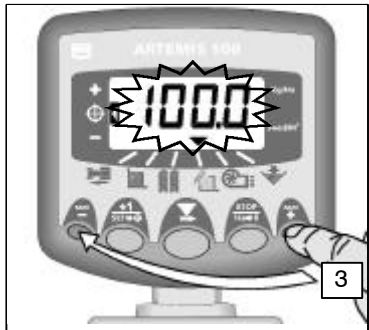

Figure 13 Adjust Target Rate

4. When the desired target rate is displayed, press and hold the $\frac{+1}{\text{SET} \rightarrow \oplus}$ button for 3 seconds (fig 14) to revert back to normal operating mode.

$\frac{+1}{\text{SET} \rightarrow \oplus}$

C.5 Set Current Rate to become new Target Rate

If the drilling rate is not currently at the target rate (rate indicator is in either position 1 or 3), then after pressing and holding the $\frac{+1}{\text{SET} \rightarrow \oplus}$ button for 5 seconds, the current drilling rate becomes the new target drilling rate (the rate indicator moves to position 2).

On releasing the $\frac{+1}{\text{SET} \rightarrow \oplus}$ button, the instrument will revert to normal operating mode.



Figure 14 Return to Normal Mode

C.6 Product Calibration

1. Place a container under the seed outlet of the metering unit and press the priming button adjacent to the metering unit, to dispense the product.



The instrument automatically switches to the programme mode, and the display will count up the theoretical weight (in grams) of product based on the calibration factor currently stored in memory.

NOTE: If the drill has an "Accord" type metering unit, you must consult the operators manual and ensure that the metering slide is set to the optimum position to achieve the required drilling rate, before the motor is calibrated.

2. Once you have dispensed sufficient product, release the priming switch and weigh the product metered out. The theoretical weight will remain flashing on the display.

NOTE: If the priming switch is held for long enough to exceed 9999 grams then the instrument will simply show 'High', informing the operator that he must re-test to ensure the weight does not exceed 9999 grams.

Press the **STOP**
Ha→0 button to re-select channel 4, and the display will reset to "0000" ready for another calibration.

5. Using the  or  button, adjust the displayed weight to match the measured weight. The longer the switch is held, the faster the number changes.
6. When the correct weight is displayed, press the  button to confirm the entry. The instrument will automatically re-calculate the calibration factor (grams/pulse of the motor encoder) and store it in memory.

The display will show "done" for 5 seconds, then the instrument will revert back to the normal display mode.

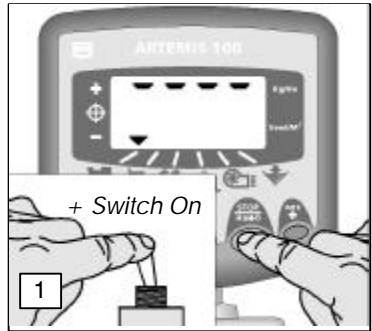

Figure 15 Enter Cal Mode 3

7. If you display the drilling rate in Seeds/m², check the T.G.W. (Thousand Grain Weight) setting is correct.

C.7 Set "Thousand Grain Weight"

The T.G.W. must be set in order enable the instrument to display a drilling rate in Seeds/m² correctly.





1. Press and hold the  button as you switch the instrument on. The instrument is then in programme mode 3 on channel 1 (fig. 15).
2. Press  to select channel 2 (). The display will show the Thousand Grain Weight in grams (fig. 16).
3. PRESS  to select the digit/decimal point to change (fig. 16).
4. HOLD  to change the digit (or move the decimal point). Releasing the button selects the next digit.
5. Switch off to exit the programme mode (fig 17).



Figure 16 Adjust T.G.W. (Channel 2)

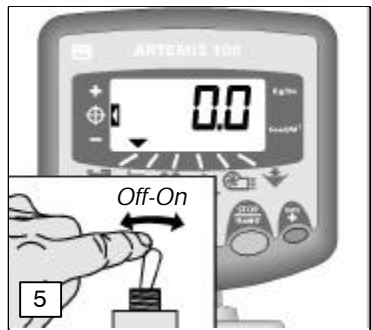

Figure 17 Return to Normal Mode

C.8 Select Unit

1. Press and hold the **STOP** **Ha→0** button as you switch the instrument on. The instrument is then in programme mode 3 on channel 1 (fig. 15).

The display shows either the top row of segments to indicate the *kg/ha* unit is selected, or the bottom row of segments to indicate that the *Seeds/m²* unit is selected.

2. Press the **▼** button to change units (fig. 18).

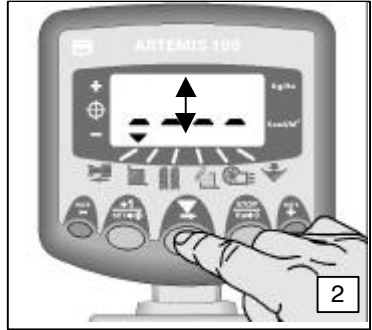

If the *Seeds/m²* unit is set, check the T.G.W. setting is correct for the product being drilled (C.7).

Figure 18: Change Units

3. Switch off to exit the programme mode.

C.9 Set % Step for Rate Offset

This sets the amount by which the rate is adjusted away from the target rate when you press the **RATE** **+** or **RATE** **-** buttons.



1. Press and hold the **STOP** **Ha→0** button as you switch the instrument on. The instrument is then in programme mode 3 on channel 1 (fig. 15).
2. Press **STOP** **Ha→0** to select channel 3 (🌾🌾🌾). The display will show a number indicating the % step (5 - 25% in 5% increments) (fig. 19).



Figure 19: Set % Rate Step

3. PRESS **▼** to select the required % step.
4. Switch off to exit the programme mode (fig. 17).

C.10 Frequently asked Questions

- **I have been drilling and there is some product left in the hopper. I think the system has under-applied.**
Perform a product calibration (C.6). If the measured amount tallies with the amount displayed on the instrument, the product calibration factor is correct. Check the forward speed sensor calibration and the implement width setting. If all these settings are correct and over/under application still occurs, there may be a problem with the motor control, in which case contact your service agent.
- **I pressed the priming switch to prime the metering unit prior to metering out the test quantity. Does this affect the calibration routine?**
Before metering out the test quantity, press the  button to re-select channel 4 and zero the instrument count. The priming quantity is then ignored. The proceed as normal (C.6).
- **I'm working in Seed/m² and then change product. Do I need to change any settings?**
You need to re-calibrate for the new product. Enter the appropriate T.G.W. value either before or after the product calibration. Failure to set the T.G.W. correctly for the product being drilled, will result in the drilling rate being incorrectly displayed.
- **I want to check for blocked coulters.**
Whilst the drill is lifted and the fan running, press the priming switch until seed is dispensed from the coulters. When you return to the cab the instrument will be flashing the theoretical weight dispensed. Simply press the  button to return to the normal display mode (the calibration factor is only recalculated if you adjust the displayed weight figure using the + / - rate buttons). Alternatively, when you move off, the instrument reverts to the normal display mode.
- **I operated the priming switch and want to continue normal drilling, without changing the calibration.**
The instrument will be flashing the theoretical weight dispensed. Don't press any buttons. Just move off and the instrument will beep three times and revert back to the normal display mode. The previously stored calibration factor will be retained and used.

D. Fan Speed Display

D.1 View Fan Speed



This channel displays the fan speed in RPM, typically about 3000 RPM (fig. 20).



Figure 20: View Fan Speed

D.2 Fan Under-Speed Alarm

If the fan speed drops below a programmed under-speed alarm level, the display defaults to this channel and shows the actual speed (flashing display). The audible alarm sounds 5 beeps. The alarm is cancelled either by pressing the  button, or when the fan speed is restored and within the normal alarm range. If the fan speed drops below the programmed under-speed level by 500 RPM or more, then motor operation will be inhibited and the instrument will beep continually. Motor operation is re-enabled when the fan speed is restored and within the normal alarm range.

The under-speed alarm is programmable (D.4), typically = 2700 RPM.

D.3 Fan Over-speed Alarm

If the fan speed goes above 4500 RPM, then the over-speed alarm sounds. The alarm is cancelled either when the  button is pressed, or when the fan speed is restored and within the normal alarm range.

The over-speed alarm threshold is non-programmable.

The alarms are inhibited if the forward speed is less than 2 km/hr.

D.4 Set Low Fan Speed Alarm

1. With the fan speed display selected, press and hold the $\frac{+1}{\text{SET} \rightarrow \oplus}$ button for 5 seconds. The instrument will then display the alarm speed with the first digit flashing (fig 21).
2. Continue holding the $\frac{+1}{\text{SET} \rightarrow \oplus}$ button as you PRESS the \blacktriangledown button to select the digit/decimal point to change (fig 22).
3. Still holding the $\frac{+1}{\text{SET} \rightarrow \oplus}$ button, HOLD \blacktriangledown to change the digit (or move the decimal point) (fig. 22). Releasing the button selects the next digit.
4. Switch off to exit the programme mode.



Figure 21: View Fan Alarm Speed



Figure 22: Change Fan Alarm Speed

E. Tramlining

There are five systems of tramlining - symmetrical, asymmetrical left, asymmetrical right 10 bout and 18 bout. The tramline bout is programmable from "oFF" (no tramlining) to 15 in symmetrical, asymmetrical left and asymmetrical right sequences.

The display defaults to the  channel after 10 seconds (unless the Area Total was selected).

Selection of asymmetrical tramlining is denoted by a decimal point on the display between the current tramline bout number on the left and the tramline bout number on the right.

Left or right asymmetric tramlining is selected in the programming mode.

NOTE: The tramline functions on the RDS Artemis 100 are identical to the RDS Multi-function Drill Control hence the illustrations depict the MFDC 100 instrument.

E.1 Manually advance bout number

Press  to advance the current bout number by one.

A decimal point indicates an asymmetric tramlining regime is selected



Figure 23: Advance Bout Number

E.2 Hold Bout number

Press  to 'hold' the current bout when the drill is lifted.

The display will flash 'StoP'.

Press  again to resume the normal bout sequence.

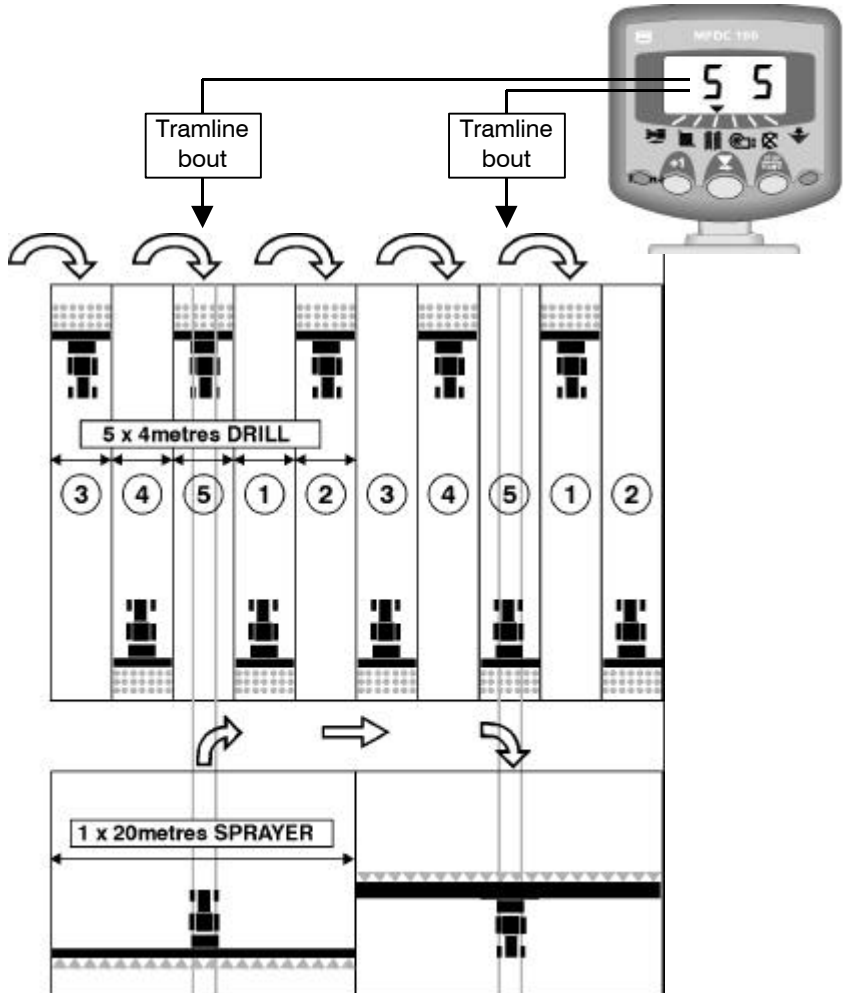

Figure 24: Hold Bout Number

E.3 Symmetrical Tramlining

Two + two seed spouts are closed during the tramline bout only. Refer to section E.5 to programme the instrument for symmetrical tramlining.

The instrument will beep once at the beginning of the tramline bout, and the display will continue flashing for the duration of the bout.



E 4.1 Asymmetrical Left Tramlining

Two seed spouts are closed on the left hand side of the drill on bouts 1 and 6. Refer to the section E.5 to programme the instrument for asymmetrical left tramlining.

The instrument will beep once at the beginning of each tramline bout, and the display will continue flashing for the duration of the bout.

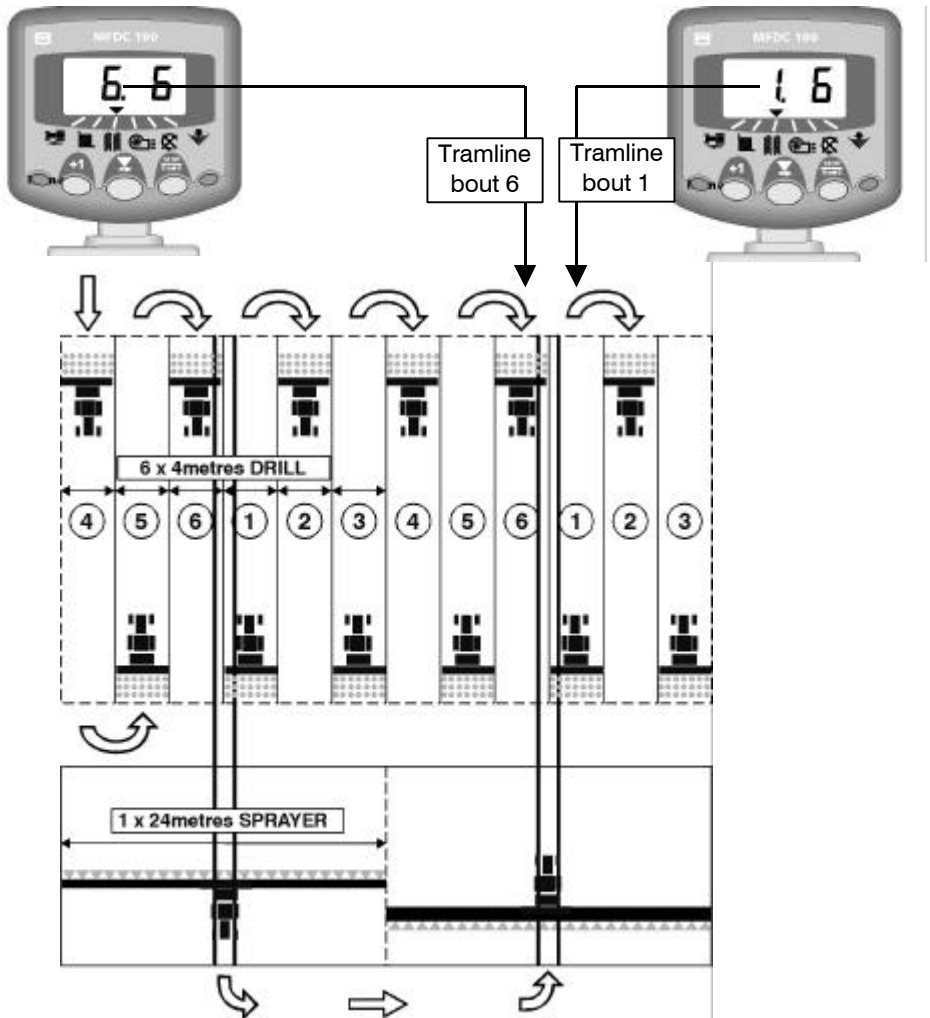

E 4.2 Asymmetrical Right Tramlining

Two seed spouts are closed on the right hand side of the drill on bouts 1 and 6. Refer to section E.5 to programme the instrument for asymmetrical right tramlining.

The instrument will beep once at the beginning of each tramline bout, and the display will continue flashing for the duration of the bout.

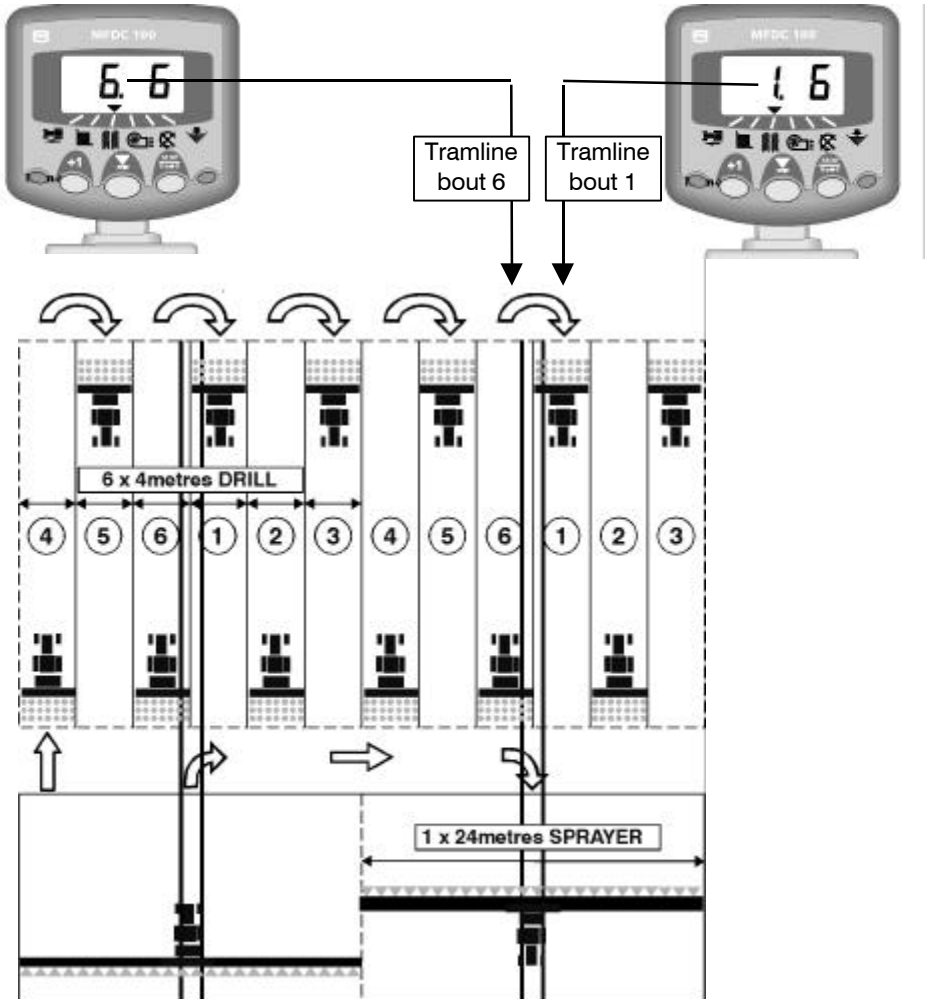

E 4.3 10-bout Tramlining

For use with an 8 metre drill and an 20 metre sprayer. (2 x 2 left hand seed spouts are closed on bouts 4 and 7, and 2 x 2 right hand seed spouts closed on bouts 2 and 9). Starting on bout 1 requires turning RIGHT at the end of the FIRST bout.

NOTE: To turn LEFT at the end of the first bout, cycle the instrument display to bout 6 before beginning.

The instrument will beep once at the beginning of each tramline bout and the display will flash for the duration of the tramline bout.

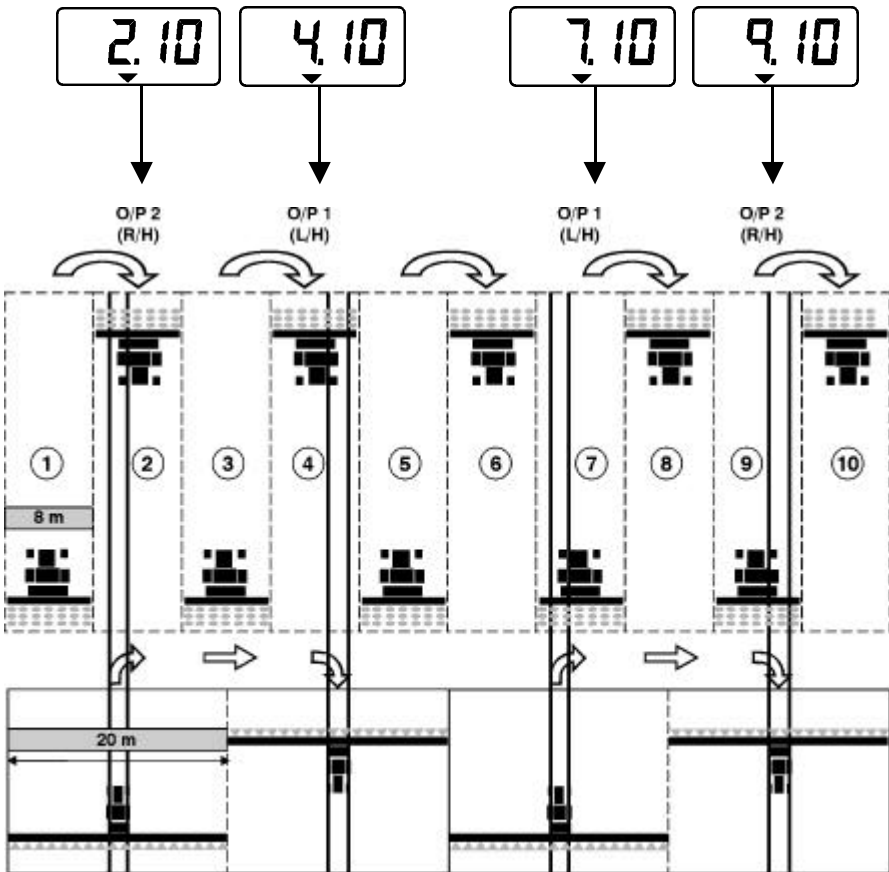

E 4.4 18-bout Tramlining

For use with a 4 metre drill and an 18 metre sprayer. (2 x 2 left hand seed spouts are closed on bouts 3 and 16, and 2 x 2 right hand seed spouts closed on bouts 7 and 12). Starting on bout 1 requires turning RIGHT at the end of the FIRST bout.

NOTE: To turn LEFT at the end of the first bout, cycle the instrument display through to bout 10 before beginning.

The instrument will beep once at the beginning of each tramline bout and the display will flash for the duration of the tramline bout.

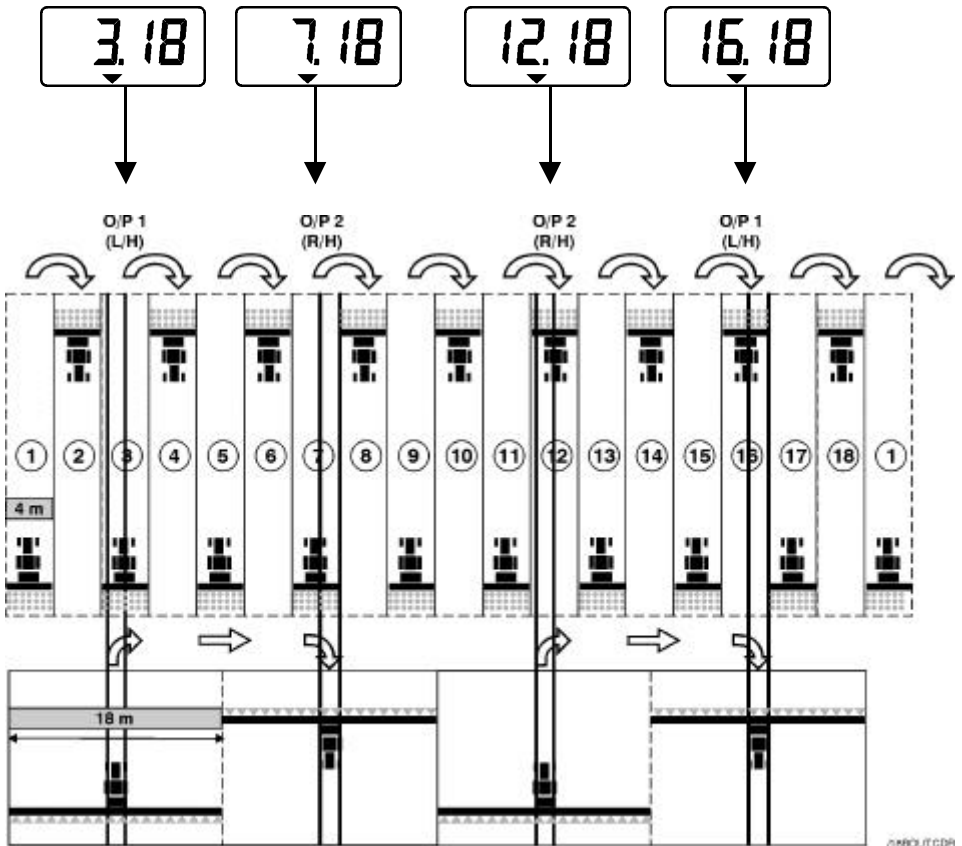

reBOUT CDR

E.5 Programme Tramline Bout

The tramline bout is programmable from 0 (no tramlining) to 15 for either Asymmetric Left or Asymmetric Right tramlining. It is also programmable for a 10-bout or 18-bout tramlining sequence.

Default value =SY 04 (Symmetrical- tramline bout 4)

1. Select the  channel.
2. HOLD  CONTINUOUSLY

The instrument enters programming mode after 5 seconds.

3. PRESS  and the tramline bout cycles ...SY05, SY06, SY07... SY15 for symmetrical tramlining,

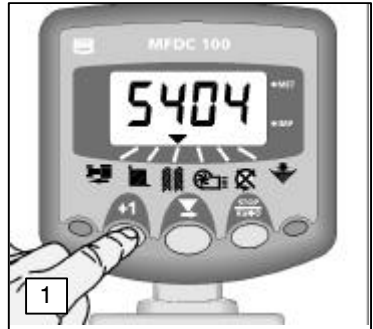

Figure 25: Select Programme Mode



Figure 26: Set Tramline Bout for Symmetrical tramlining

... then AL.00, AL.01, AL.02 ... AL.15 for Asymmetric Left tramlining.

Setting SY00 or AL.00 switches off the tramlining function.

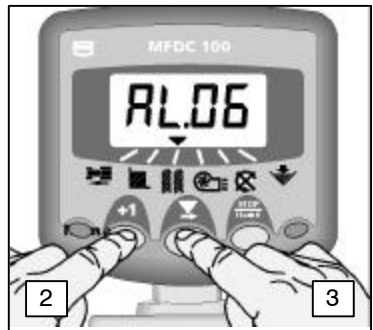

Figure 27: Set Tramline Bout for Assymmetrical Left tramlining

... then **Ar.00**, **Ar.01**, **Ar.02** ... **Ar.15** for Asymmetric Right tramlining.

Setting **Ar.00** switches off the tramlining function.

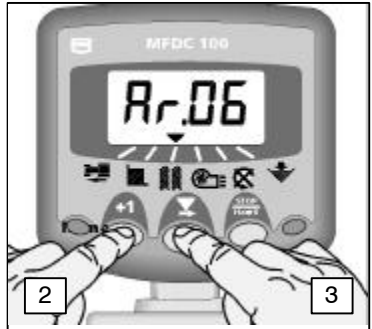

Figure 28: Set Tramline Bout for Assymetrical Right tramlining

... then **AS.10** for 10 bout tramlining...

...followed by **AS.18** for 18 bout tramlining.



Figure 29: Set Tramline Bout for 10-bout/18-bout tramlining

F. Hopper level Alarm



When either hopper level sensor is uncovered, the instrument will beep 3 times and the display will default to the hopper level channel ().

The display will flash either 'Lo. 1' or 'Lo. 2' (dependant upon which sensor is uncovered) or 'Lo.1.2' if both are uncovered.

The alarm function can be disabled in programme mode 1 if desired (see section G).



Figure 30: Hopper 1 Low Alarm



Figure 31: Hopper 2 Low Alarm



Figure 32: Both Hoppers are Low

G. Programme Functions and Fault Diagnosis

G.1 Programme Modes 1 –4

Some settings do not need to be accessed during normal operation, unless the instrument is transferred to another tractor/implement. Those that do are explained in the operators section (sections A - F) of the manual.

| | Mode 1 | Mode 2 | Mode 3 | Mode 4 |
|--------------------------|--|---|--|--|
| Mode Entry | From normal display mode, select channel and hold +1 button continuously | Press and hold +1 button for 10 seconds while switching instrument on | Press and hold STOP button while switching instrument on | Press and hold RATE+ button for 10 seconds while switching instrument on |
| Channel selection | As above | Press +1 button | Press STOP button | Press RATE+ button |
| Channel 1 | Speed Sensor Factor [7.78 mm/pulse] (see section A.3) | Motor Control On (1) / Off (0) [1] | Unit Selection [kg/ha] (see section C.8) | Motor selection [typ.1] |
| Channel 2 | Implement Width [4.0 m] (see section B.3) | Total Area (non-resettable) | T.G.W. [45.00 g] (see section C.7) | Dist. Shaft 1 Cal Factor [3.0 p.p.r] |
| Channel 3 | Tramline Regime /Bout [SY 04] (see section E.5) | Tramline Function On (1) / Off (0) [1] | Rate - % Step [5%] (see section C.9) | Dist. Shaft 2 Cal. Factor [0.0 p.p.r.] |
| Channel 4 | Drilling Target Rate [100 kg/ha] (see section C.4) | ----- | Cal. Weight (0-9999 grams) (see section C.6) | Motor Calibration Speed [800 rpm] |
| Channel 5 | Fan Under-Speed Alarm [2700 rpm] (see section D.4) | Fan Speed Cal Factor [1.0 p.p.r] | Cal Weight "Done" | ----- |
| Channel 6 | Hopper Level Alarm On (1) / Off (0) [1] | Shaft Confirmation Alarm On/Off [1] | ----- | HBM type [typ.1] |

G.2 Error Codes

Due to the extra features included within the CAN modules there are a number of extra alarms that will be displayed as fault codes. These codes are given below and the system rectified accordingly.

The alarms are split into 2 categories, those that are indicated irrespective of cut-out status and those that are only indicated if the drill is being registered as in work.

G2.1 Alarms irrespective of "Work" Status

When a fault condition exists, the instrument will beep 5 times every 30 seconds.

| Fault Code | Explanation | Rectification |
|-------------------|--|--|
| F100 | The instrument does not recognize the Motor Control Module (MCM) as being connected. | Check the plug connections. |
| F101 | The MCM is overheating. | Allow to cool down and check the metering unit for blockage etc. |
| F103 | The motor is overheating. | Allow to cool down and check the metering unit for blockage etc. |
| F200 | The instrument does not recognize the H/Bridge Module (HBM) as being connected. | Check the plug connections. |
| F201 | The outputs from the HBM used to operate the Tramline 1 solenoid / actuator are drawing too much current | Check the solenoid / actuator operation. |
| F202 | The outputs from the HBM used to operate the Tramline 2 solenoid / actuator are drawing too much current | Check the solenoid / actuator operation. |

G.2.2 Alarms when the drill is in work

When a fault condition exists, the instrument will beep 5 times every 30 seconds.

| Fault Code | Explanation | Rectification |
|-------------------|--|---|
| F102 | The rotary encoder on the motor has failed and power to the motor is stopped. | Check connections to motor. |
| F104 | The motor is drawing too much current. | Check the metering unit for blockage etc. |
| F105 | The actual motor speed is 5% or more than the theoretical target speed. | |
| F106 | The actual motor speed is 5% or less than the theoretical target speed. | |
| F107 | No pulses are being received on the shaft confirmation inputs. The metering shafts have stopped rotating. | Check the Shaft Confirmation Alarm is switched on (Programme Mode 2 - CH. 6). Check metering unit. |