



ASC 200

Automatic Section Controller

Installation and Operation

RDS Part No.:	S/DC/500-10-569
Document Issue:	2.0 : 23/2/09
Reference:	1-1252 Version 1.1 Rev. A

Electromagnetic Compatibility (EMC)



This product complies with Council Directive 2004/108/EC when installed and used in accordance with the relevant instructions.

Service and Technical Support

For service and support, please contact;

RDS Technology Ltd
Cirencester Road,
Minchinhampton,
Stroud, Glos
GL6 9BH

Tel : +44 (0) 1453 733300
Fax : +44 (0) 1451 733311
e-mail : info@rdstec.com
web : www.rdstec.com

© Copyright RDS Technology Ltd 2009

Our policy is one of continuous improvement and the information in this document is subject to change without notice. Check that the software reference matches that displayed by the instrument.

\\UK569200.DOC

1.	OVERVIEW	5
1.1	ASC 200 Standard Features	5
1.2	Typical Uses of the ASC 200	5
	Spraying around obstacles	5
	Spraying the headlands	5
1.3	ASC 200 Components	6
2.	INSTALLATION	7
2.1	Vehicle Power Supply	7
2.2	Installing the ASC 200	8
3.	SYSTEM SETUP	9
3.1	The Front Panel	9
3.2	The Back Panel	9
3.3	Functional Modes	10
	3.3.1 Operational Mode	10
	3.3.2 Setup Mode	10
3.4	Configuring the GPS	10
	3.4.1 Set 'GPS Type'	10
	3.4.2 Set GPS Baud Rate	11
	3.4.3 Set DGPS mode	11
	3.4.4 Set Velocity Filter	11
	3.4.5 Set GPS Alarm	11
	3.4.6 Set GPS Antenna Offsets	12
	GPS Offset - 'Crosstrack'	12
	GPS Offset - 'Longtrack'	12
	3.4.7 GPS Status	12
	3.4.8 GPS Health	12
	3.4.9 Testing the GPS connection	13
3.5	Boom settings and Spraying parameters	14
	3.5.1 Controller Type	14
	3.5.2 Set Master Control Switch (MCS)	14
	3.5.3 No. of Boom Sections / Boom Width	14
	3.5.4 Boom Translation	15
	3.5.5 Configure for Front Boom	15
	3.5.6 Configure 'Mid Offset'	16
	3.5.7 Spray parameters	16
	'Miss' Tolerance	16
	'Min Delay'	16
	'Latency On'	16
	'Latency Off'	16
	3.5.8 Measuring Latency	18
	3.5.9 Testing the Voltage Switch cable	20
	3.5.10 ASC 200 'Self Test'	20
	3.5.11 Testing the ASC 200 in the field	21
3.6	Measuring Vehicle and Boom Offsets	22
	3.6.1 Link and Axle Distances	22
	3.6.2 Measurements - Tractor with trailed sprayer	23
	3.6.3 Measurements - Tractor with trailed tank and sprayer	24
	3.6.4 Measurements - Self-propelled sprayer – rear-mounted boom	25
	3.6.5 Measurements - Self-propelled sprayer – front-mounted boom	26
	3.6.6 Measurements - Self-propelled sprayer – Mid-mounted split boom	27

4.	USING THE ASC 200	28
4.1	Some points to remember before you start	28
4.2	Starting a Field.....	28
4.2.1	Clearing a Field from Operational Mode	28
4.2.2	Clearing a Field from Setup Mode	29
4.3	Using the ASC 200 to Spray a Field	29
4.4	'Forced Start' (Section Control).....	30
4.5	Suspending & Resuming Spraying Operations in the Field.....	30
4.6	Starting a New Field	30
4.7	Override Function.....	30
4.7.1	Overriding sections ON or OFF <u>sequentially</u> from the left or right	31
4.7.2	Overriding <u>all</u> sections ON or OFF	32
4.7.3	Overriding <u>individual</u> sections ON or OFF	32
5.	THE MENU SYSTEM	33
5.1	Navigating the Menus.....	33
5.2	The Menu Structure.....	35
6.	APPENDICES	36
	Appendix 1 - System Messages.....	36
	Appendix 2 - Resetting the System.....	37
	Soft Reset	37
	Hard Reset	37
	Appendix 3 - Troubleshooting	38
	Appendix 4 - Connector Pin-Outs	39
	Ports A and B Connectors	39
	Power Input Connector	40
	Section Controller Connector	40
	Appendix 5 - Specifications	41
	Document History.....	42

1. Overview

Welcome to the ASC 200 User Manual. This document describes how to use the ASC 200 system.

The ASC 200 system is designed to connect to your existing Spray Rate Controller and GPS guidance system to provide automatic boom section control. This will greatly reduce the need for manually switching sections ON or OFF when going over previously sprayed crop or pasture. Its ability to automatically control the spraying state of the sections relieves the operator from a demanding task, which requires split second timing on multiple switches. The ASC 200 is an autonomous system, which can be interfaced with most existing spray rate controllers and GPS receivers.

This manual is designed to assist users of the ASC 200 in the operational use of the ASC 200 hardware and software.

1.1 ASC 200 Standard Features

Timing Delays	The ASC 200 can be adjusted for delays from electrical to mechanical switching.
Variable Overlap	Allows the operator to configure the required overlap.
Vehicle Modeling	Allows the operator to accurately define vehicle and boom dimensions for greater accuracy.
Antenna Offsets	Allows the operator to define the GPS antenna offsets.

1.2 Typical Uses of the ASC 200

Spraying around obstacles

Automatically minimize over spray around trees or rock heaps. ASC 200 detects areas previously sprayed and shuts down sections and reactivates as necessary.

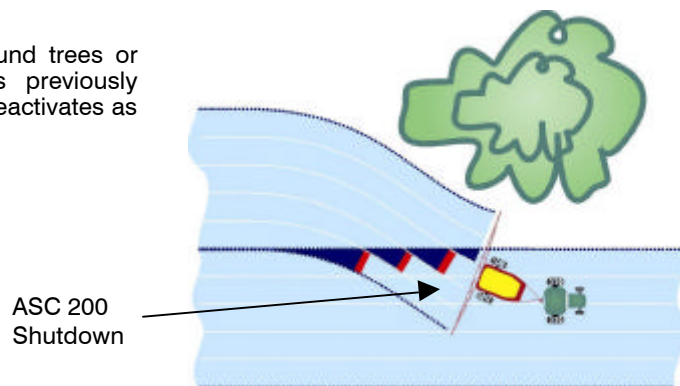

Spraying the headlands

ASC 200 detects areas previously sprayed as the headlands are approached and shuts down sections and reactivates as necessary.

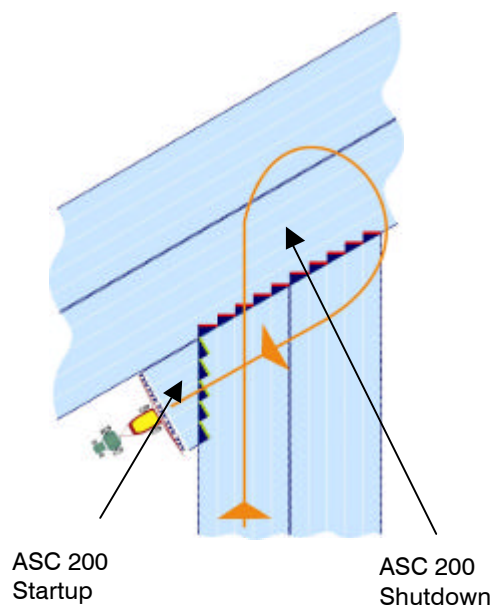

1.3 ASC 200 Components

Kit Ref. P/ASC200 and P/ASC200-EVRARD

When you receive your ASC 200 system, please check that you have received all of the components detailed on the packing list. A typical kit would comprise of the items below.

Qty	Description	Part No.	
1	ASC 100 Controller (1-0490)	S/HU/381-2-001	
1	Power Cable (1-2408)	S/CB/381-2-006	
1	Mounting Kit	S/AC/381-2-007	
1	GPS Interface Cable (1-2207)	S/CB/381-1-008	
1	Installation kit (1-0222)	S/CB/381-2-009	
1	Voltage Switch Cable (1-2805) <i>(Kit Ref. P/ASC200 only)</i>	S/CB/381-1-005	
1	Controller I/F cable Installation Leaflet	S/DC/500-10-574	
1	ASC 200 User Manual	S/DC/500-10-569	
1	ASC 200 Quick Start Card	S/DC/500-10-568	

Inspect all items for visual damage. If any component appears to be damaged, contact your supplier immediately. Ensure all packaging and shipping details are kept for future reference.

2. Installation

A schematic of the ASC 200 and how it connects to the spray rate controller and GPS receiver is shown in Figure 1

Figure 1: Schematic layout of the ASC 200

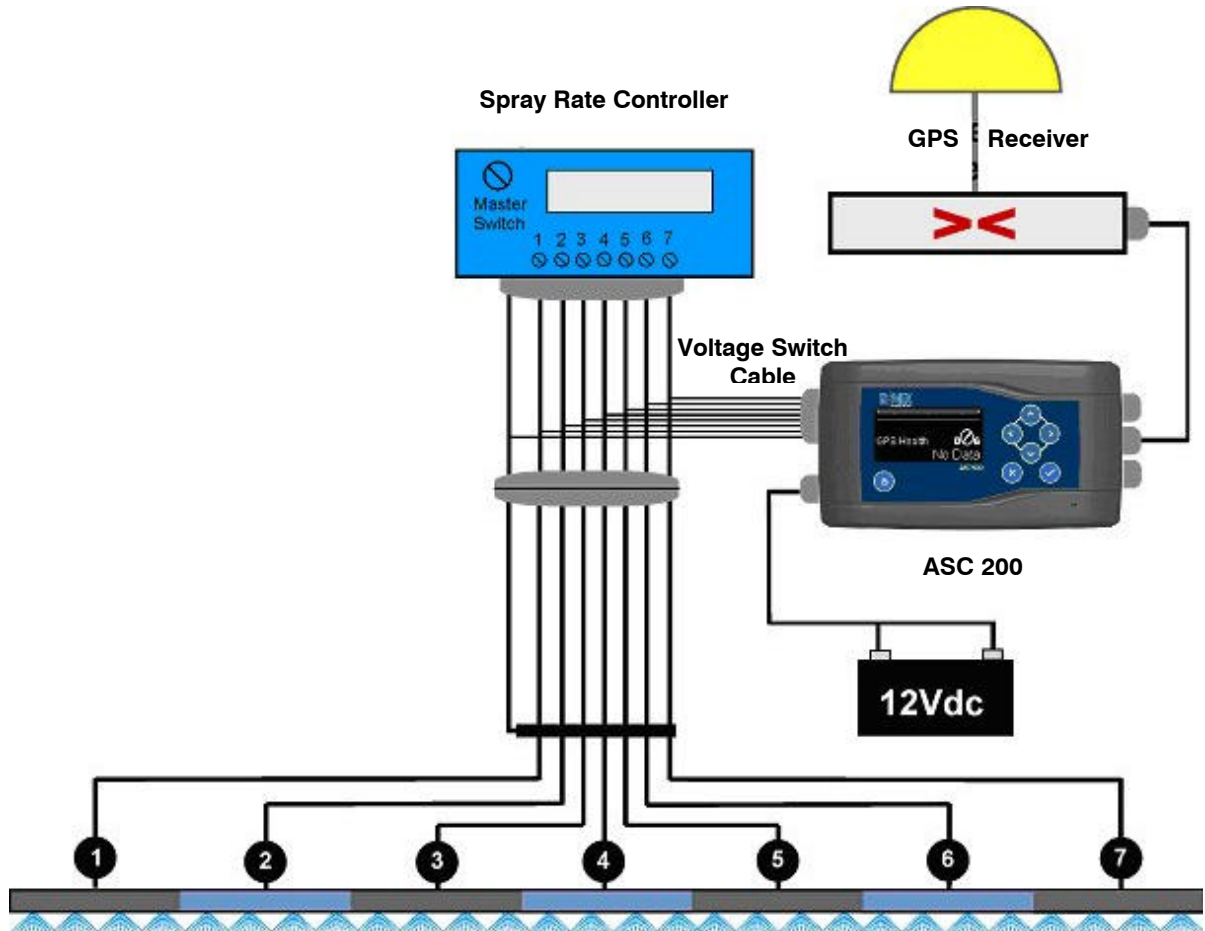

It is recommended that all electrical wiring should be installed by a qualified fitter/technician. Incorrect wiring may damage the ASC 200 controller, the spray rate controller, or both.

2.1 Vehicle Power Supply

The ASC 200 is designed to operate from a clean 12Vdc power source. The use of a cigarette lighter socket is not recommended as the plug may become loose and cause intermittent power to the ASC 200. The ASC 200 is fitted with an internal self-resetting fuse, hence it is not necessary to fit an in-line fuse to the power cable. However if the cable is connected directly to the vehicle's batteries it is recommended that a fuse be fitted accordingly.

RED = +V, BLACK = 0V

The ASC 200 is fitted with an Isolation Power Switch (IPS) on the rear panel. This switch completely removes power from the ASC 200 controller. The IPS should be set to the Off Position (0) if the vehicle will not be used for several months to prevent any power drain from the vehicle. The standard 12Vdc power cable (P/n 1-2408) supplied with ASC 200 is designed for a maximum of 8A operation.



The power cable should be carefully routed so as not to rub or wear through which may lead to a short circuit on the vehicle.

2.2 Installing the ASC 200

The following table summarises the installation and commissioning procedure. Please refer to the appropriate section as indicated, for further information.

Step	Instruction	Additional information
1.	Assemble the mounting kit , S/AC/381-2-007. Using the four screws to secure the mounting bracket to the ASC 200 controller.	-
2.	Install the ASC 200 Controller in a suitable location in the vehicle to allow the operator to have access to the front panel. Four screws are provided to mount the controller to the vehicle. Ensure that the Isolation Power Switch is in the OFF (O) position.	-
3.	Connect power cable S/CB/381-2-006 to the vehicle battery and switched power supply.	Section 2.1
4.	Connect GPS interface cable S/CB/381-1-008 to the GPS receiver.	Section 3.4
5.	Connect the Voltage Switch cable S/CB/381-1-005 to the spray controller. Further details are provided with the Voltage Switch cable.	Voltage Switch cable Installation Leaflet. Section 3.5
6.	<p>Check Operational Status</p> <p>Slide the Isolation Switch to the On Position (1) and press the power button on the front of the unit. There will be a delay of approximately 15 seconds while the unit powers up.</p> <p>The display panel will be activated, showing the Operational menu information. This confirms that the unit has been correctly installed and powered.</p> <p>The ASC200 is now ready to be calibrated and tested.</p>	-
7	<p>Configure GPS</p> <p>GPS Type (accept default) Baud Rate DGPS mode (accept default) Velocity Filter GPS Alarm GPA Antenna Offset(s)</p>	<p>Section 3.4.1 Section 3.4.2 Section 3.4.3 Section 3.4.4 Section 3.4.5 Section 3.4.6</p>
8	<p>Configure Boom Sections</p> <p>Controller Type Master Control Switch (MCS) No. of boom sections / Section width Boom Section Translation Vehicle and Boom Offsets</p>	<p>Section 3.5.1 Section 3.5.2 Section 3.5.3 Section 3.5.4 Section 3.5.5 Section 3.5.6 Section 3.6</p>
9	<p>Test System</p> <p>GPS connection Voltage Switch Cable connection Self-test (Boom sections)</p>	<p>Section 3.4.9 Section 3.5.9 Section 3.5.10</p>
10	<p>Fine tuning (Spraying parameters)</p> <p>Spray parameters Measuring Latency Testing the ASC 200 in the field</p>	<p>Section 3.5.7 Section 3.5.8 Section 3.5.11</p>

3. System Setup

This section details the steps taken for the first time user of the overall system. Furthermore this section describes the necessary information (including vehicle measurements), to ensure that the system will function correctly.

3.1 The Front Panel

Figure 2: The ASC 200 Front Panel

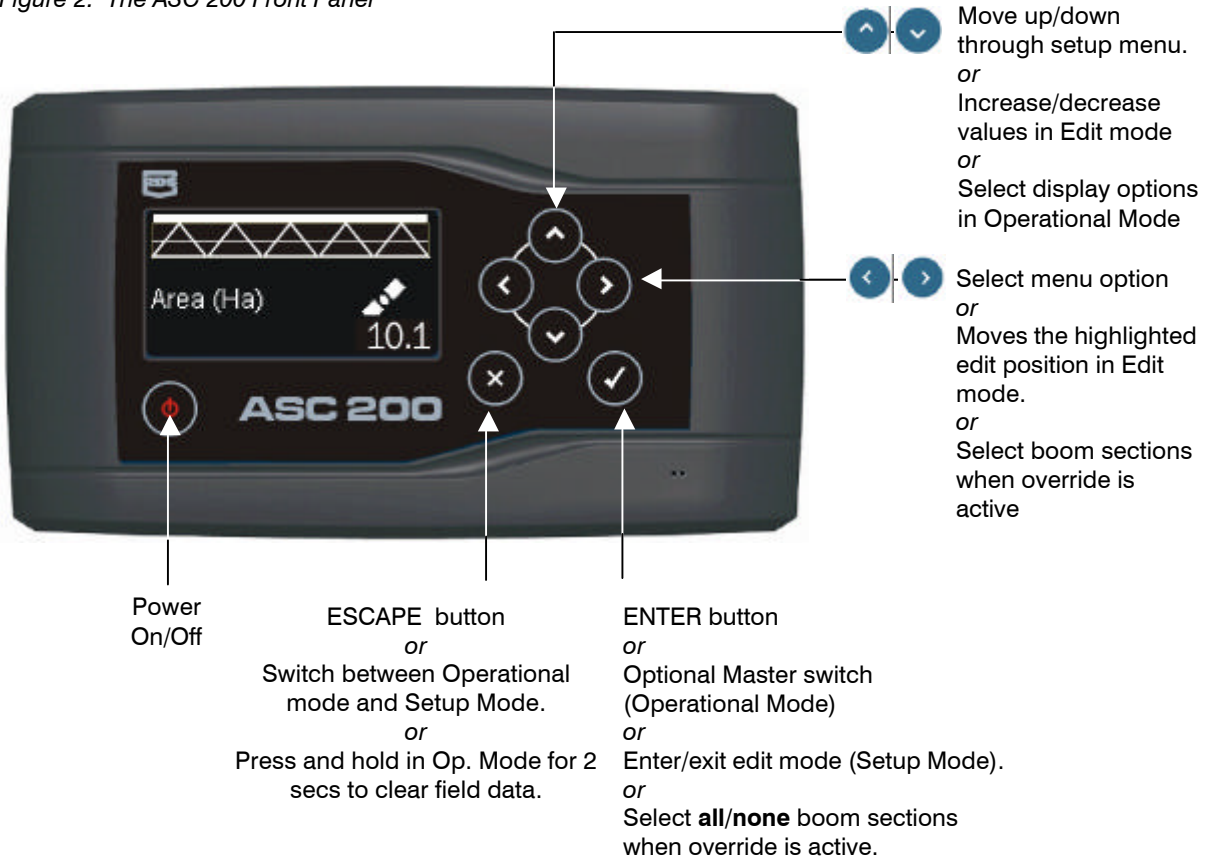

3.2 The Back Panel

Figure 3: The ASC 200 Back Panel

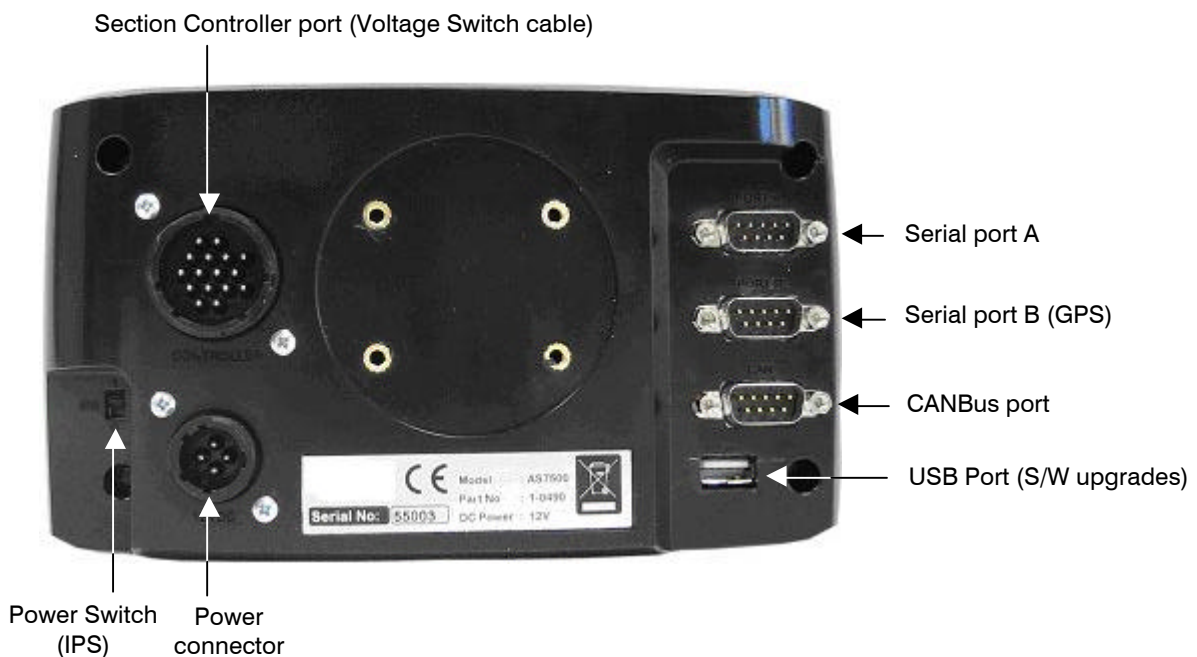

3.3 Functional Modes

The ASC 200 has two functional modes, Operational mode and Setup mode. The  key toggles the ASC 200 between Operational and Setup mode.

3.3.1 Operational Mode

The Operational mode allows the ASC 200 to automatically control the boom sections, and provides the operator with status information when working in the field.

Figure 4: Example display in Operational mode

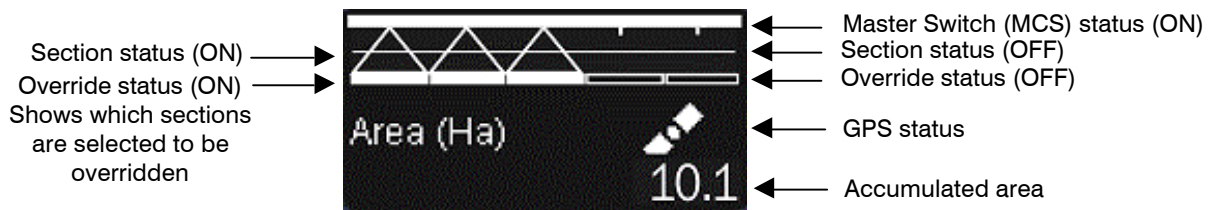

3.3.2 Setup Mode

The Setup mode allows the user to configure the ASC 200 as required. The Setup menu is indexed to allow the user to easily step through the menu as required.

Figure 5: Example display in Setup mode

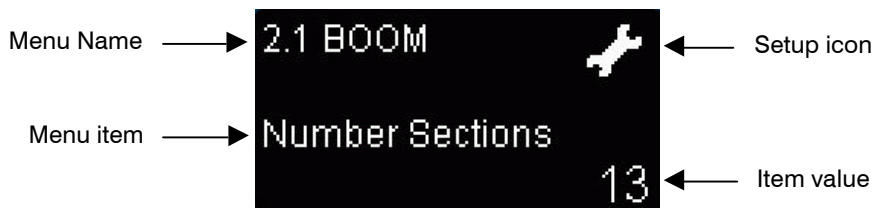

NOTE: When in Setup mode, the ASC 200 does not record any spraying completed.

3.4 Configuring the GPS

The ASC 200 will operate with almost any GPS receiver or guidance system, which can output an NMEA message via RS232. It does not require a GPS mapping screen to operate. GPS requirements are:

NMEA message GGA (VTG optional)
 Update rate 5Hz
 Baud rate 19,200 baud (default - optional settings available)

3.4.1 Set 'GPS Type'

The unit is supplied with an RS232 serial GPS cable only. Connect the receiver to port 'B'.

To view / set in Setup mode, select 'Settings' – 'GPS Type'.

Default setting = 'NMEA' (RS232 - Port 'B').

Option: 'NMEA 2000' (CANBus port 'C' - cable not supplied)



3.4.2 Set GPS Baud Rate

The baud rate of the ASC 200 must match that of the receiver, otherwise data will not be received.

To maximise performance, configure the ASC 200 with the fastest baud rate that the receiver will support,

Default setting = 19200 baud.

Options: 9600 / 19200 / 38400 / 115200

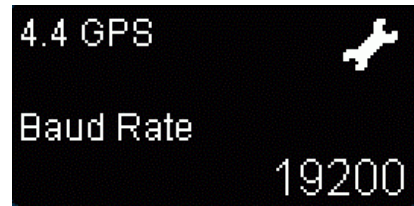

3.4.3 Set DGPS mode

For maximum accuracy, the ASC 200 needs a differentially-corrected GPS signal (DGPS). There are several common forms of DGPS correction services which include WAAS, EGNOS, Beacon (Coast Guard), OmniSTAR®, and StarFire®. All of these services provide a more accurate GPS position and are recommended for use with the ASC 200. Furthermore, RTK signals may also be used.

To view / set in Setup mode, select 'GPS' – 'Diff Required'.

Default setting = 'Yes'

Option: 'No'

If set to 'Yes', the 'GPS Health' message in Operational mode, displays whether the received GPS message is differentially-corrected.

If set to 'No', the unit will function with or without differential correction. In the OPERATIONAL mode with the master switch ON, an audible alarm will sound if the 'GPS Health' message is other than 'Good GPS', or 'No DGPS'

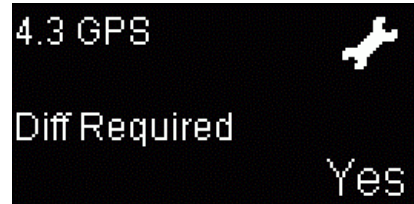

NOTE: The use of non-corrected GPS signals should be avoided if possible, as this will have a direct impact upon the accuracy of the overall system (although the 'Velocity Filter' setting will minimise the inaccuracy).

3.4.4 Set Velocity Filter

If the ASC 200 is operated with non-corrected GPS signals the heading of the spray rig may be erratic, which may cause irregular behaviour of boom sections shutting On and Off, particularly on the outside sections.

To minimize this effect the VTG (heading) message may be disabled and the ASC 200 can smooth the vehicle's heading using a 'Velocity Filter'. The filter may be increased in magnitude to further dampen the erratic behaviour of the non-corrected GPS signals.

It is however, recommended to use DGPS to provide optimal accuracy with the overall system. It is the operator's responsibility to determine the accuracy of the GPS.

NOTE: Velocity Filter has no effect when the \$VTG string is being received.

Default setting = 0 (filter disabled)

Options: 1 – 9 (VTG message disabled – filter active)

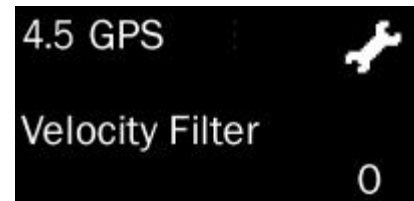

3.4.5 Set GPS Alarm

When the 'Diff Required' setting (3.4.3) is set to 'Yes', and the unit is in the OPERATIONAL mode with the master switch ON, an audible alarm will sound if the 'GPS Health' message is other than 'Good GPS'.

When the 'Diff Required' setting (3.4.3) is set to 'No', and the unit is in the OPERATIONAL mode with the master switch ON, an audible alarm will sound if the 'GPS Health' message is other than 'Good GPS' or 'No DGPS'.

To disable the audible alarm, in Setup mode select 'General' – 'Sound', and set 'No'

Default setting = 'Yes' (Audible alarm enabled)

3.4.6 Set GPS Antenna Offsets

When using GPS, the actual position is computed at the GPS antenna. However this is not the physical location where the sections are located. Hence it is necessary to measure the distances or 'offsets', from the GPS antenna to the physical section.

The distance between the GPS antenna and the boom sections is not measured directly between the points. The ASC 200 provides accurate modelling of the boom by measuring points along the length of the spray rig to compute the orientation of the boom relative to the vehicle.

GPS Offset - 'Crosstrack'

Most GPS antennae are located along the centreline of the vehicle and/or spray rig. However, if for some reason the antenna is offset from the centreline, then it will be necessary to enter a **Cross Track** value.

Measure the distance and enter a positive value if the antenna is to the right of the centreline of the vehicle, as viewed from the rear of the tractor facing forwards.

Enter a negative value if the antenna is to the left of the centreline of the vehicle, as viewed from the rear of the tractor facing forwards.

Default setting = 0.00

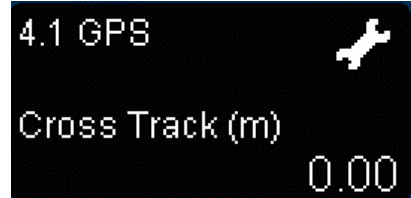

GPS Offset - 'Longtrack'

The distance from the GPS antenna, to the centreline of the front axle on the spray vehicle. If a front boom is used, the 'Longtrack' measurement is to the flow point of the boom and not the front axle.

Default setting = 0.00

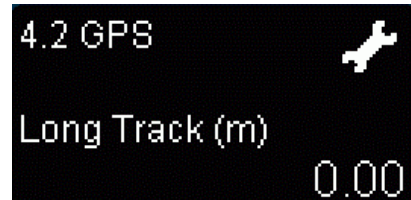

3.4.7 GPS Status

The number of satellites used by the GPS receiver / guidance system is reported in the GPS status message on the display panel. It is necessary to have four or more satellites for a valid GPS position.



3.4.8 GPS Health







Further to the GPS Status, the GPS Health is a summary of several parameters related to the GPS data. 'GPS Health' messages are explained in the following table.

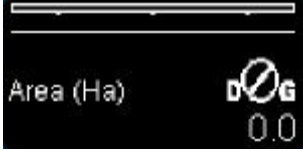

Message	Description
Good GPS	Good DGPS data is being received (GGA message only).
Good GPS (V)	Good DGPS data is being received (GGA & VTG messages).
No DGPS	Good GPS data is being received but no differential correction signal is received.
Poor GPS	Poor DGPS data is received, less than 4 satellites or a PDOP greater than 10. The ASC200 will not function.
No Pos	Correct data type & baud rate, no GPS position given in the data.
No NMEA	Invalid data being received.
No Data	There is no data being received through the GPS port.

3.4.9 Testing the GPS connection

Once the ASC 200 has been correctly configured for the GPS, it should be tested for correct operation as described below;

Step	Instruction	Screen
1	Start the ASC 200 unit using the On/Off button. The unit will start into the Operational mode after about 15 seconds and the display panel will appear as shown until a valid GPS signal is received.	
2	Once the unit is receiving valid DGPS information on the correct port, the display will show a moving satellite symbol as shown.	
3	Scroll to the GPS health messages using the  or  buttons. If no GPS data is being received, the display will be as shown.	
4	Once GPS data is received, the message will change to show the status of the GPS data being received. See section 3.4.8 for a description of the GPS health messages.	

If the test procedure fails, confirm that the GPS receiver / guidance system is correctly configured and that the data cable is connected to the correct port on the ASC 200 controller.

3.5 Boom settings and Spraying parameters

When setting up the ASC 200 for the first time or for use in a new vehicle, there are various boom settings that must be configured for ASC 200 to function correctly and accurately.

Measurements for Vehicle and Boom offset dimensions are described in section 3.6

3.5.1 Controller Type

By default, the ASC200 is configured to control automatic boom section switching via the voltage switch cable connected to the Section Controller port.





3.5.2 Set Master Control Switch (MCS)

The Master Control Switch is the switch (source) used to control both the ASC 200 controller and the Spray Rate Controller (SRC).

The vast majority of SRC's have a master switch used to switch all sections On and Off as required. Ideally this will be setup as the MCS, and the 'Master Source' setting should be 'External'.

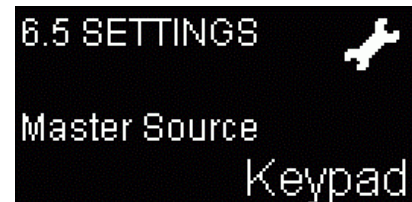
However in some cases, it is not possible or practical to use this as the MCS. In these cases the keypad of the ASC 200 may be used as the MCS, and the 'Master Source' setting is left as the default 'Keypad'.



Control Setting	Device Used
'Keypad'	The  button on the front panel of the ASC 200 controller (default setting).
'External'	Typically this will be the Master switch on the SRC. The ASC 200 requires a constant 12Vdc signal on pin 11 of the Section Controller Port.
'Bipole' [see note]	Typically this will also be the Master switch on the SRC. It observes a 12Vdc pulse on one wire (pole) to open the valve and then a 12Vdc pulse on the opposite wire (pole) of the valve to close it. The ASC 200 requires 12Vdc pulse on pins 11 and 16 of the Section Controller Port.

NOTE: With 'Bipole' selected as the MCS, only 12 boom sections can be used on the Section Controller port. 'Bipole' must be set as the MCS before the cable is connected to the Section Controller port otherwise either the ASC 200, or the SRC, or both units may be damaged.

NOTE: The 'Bipole' configuration is not possible with the Voltage Switch cable supplied. This cable only allows for up to 8 sections to be controlled.

3.5.3 No. of Boom Sections / Boom Width

The Boom Settings determine the overall width of the spray boom being used. From the 'Boom' menu,

(i) Enter the number of boom sections.

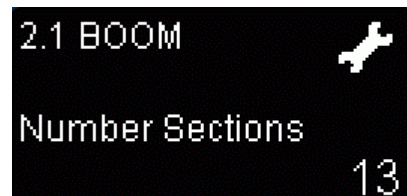

(ii) Enter the width for each section in turn.

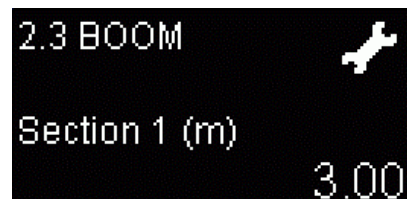

3.5.4 Boom Translation

The 'Translation' option is used when the boom sections do not map "one-to-one" to the outputs of the Section Controller port.

To use 'translation', edit the character in each boom section position and change it to the position that it is to be mapped to.



As an example, if a five section boom had two additional switches placed for further control of the two outer most sections, then it would be necessary to translate which sections would be activated by the ASC 200. In this example it would be necessary to have the translation as shown in the sequence beneath the boom in Figure 5a.

Figure 5a: Assigning Section Controller Outputs to Boom Sections / Fence Line / End Nozzles

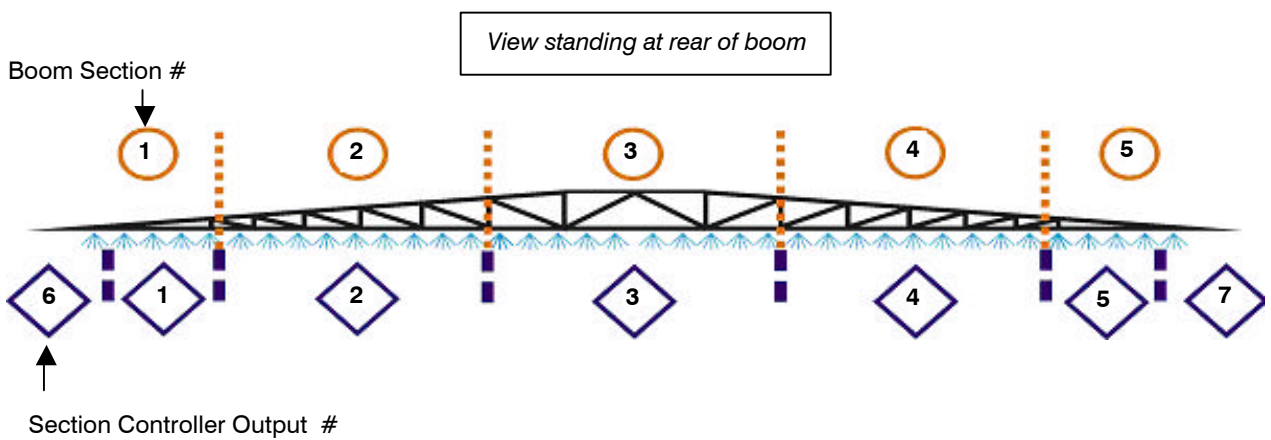

3.5.5 Configure for Front Boom

The 'Front Boom' option is used when the physical boom is located at the front of the vehicle. The location of boom will be modelled correctly when this option is selected as 'Yes'.

Dimensions for a self-propelled, front-mount boom sprayer should be recorded in section 3.6.5

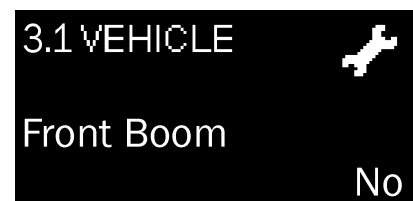
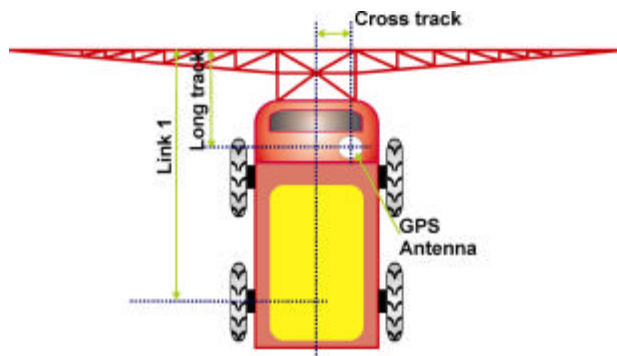

3.5.6 Configure 'Mid Offset'

The 'Mid Offset' option is used when the physical boom is split along the longitudinal axis of the vehicle. Typically this will be on a self-propelled sprayer with mid-mounted boom and the central part of the boom at the rear of the vehicle. The mid-offset for the boom is for one central section of the boom only and must be one complete section for the boom section switches.

Dimensions for a self-propelled, mid-mount, split boom sprayer should be recorded in section 3.6.6

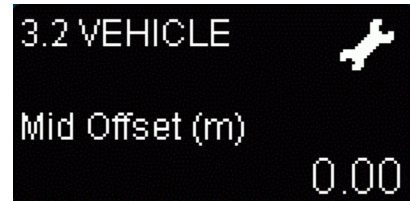
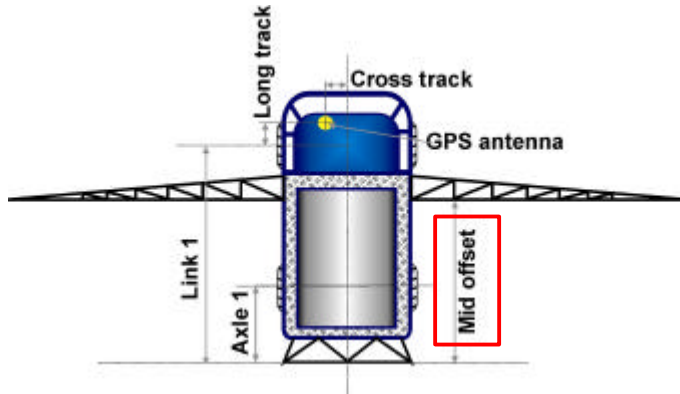

3.5.7 Spray parameters

The following parameters are used when determining when to turn the spray valves on and off. To optimize the usage of the ASC 200 it is important that these settings are configured correctly.

'Miss' Tolerance

The 'Miss' Tolerance is used to decide when to turn valves on or off. When set to its default of 1%, the system will turn the valves on whenever any part of the sensed area has not been sprayed. It is effectively the percent of miss that the system will tolerate. If the value is increased, the system will not turn the valves on when traversing over a small missed area such as a line between two spray swaths.

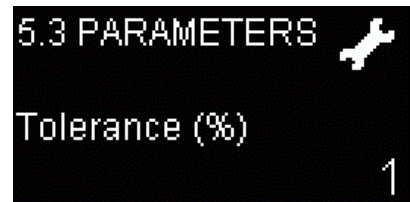

'Min Delay'

This value defines the minimum amount of time that should elapse before a section that has been switched Off can be again turned On, and vice-versa. The feature is designed to prevent problems due to fast switching of solenoid valves.

The entered value is a percentage of the sum of the 'Latency On' and 'Latency Off' values (see over).

NOTE: This is an advanced tuning parameter and should only be changed from its default value under instruction from authorised support personnel.

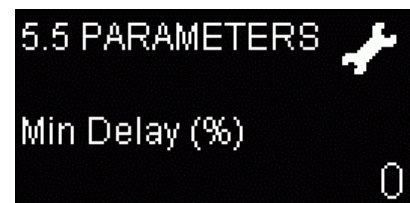

'Latency On'

'Latency On' is used to compensate for any time delay between the time the system requests the valves to open, and the actual time that this takes place. For example, if it takes one second for a valve to open, a 'Latency On' of one second should be entered. In this case the signal to open the valve will be sent to the valve a second before the valve needs to open (ref. fig. 6).

To measure latency, please refer to section 3.5.8.

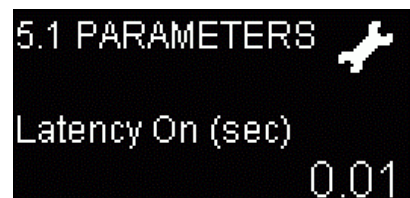

'Latency Off'

'Latency Off' is opposite to 'Latency On' and is used to compensate for any time delay between the time the system requests the valves to close, and the actual time that this takes place. (ref. fig. 6).

To measure latency, please refer to section 3.5.8.

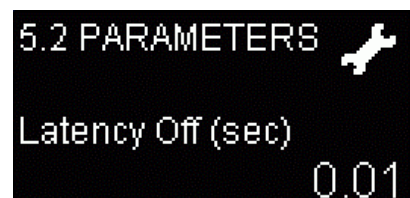
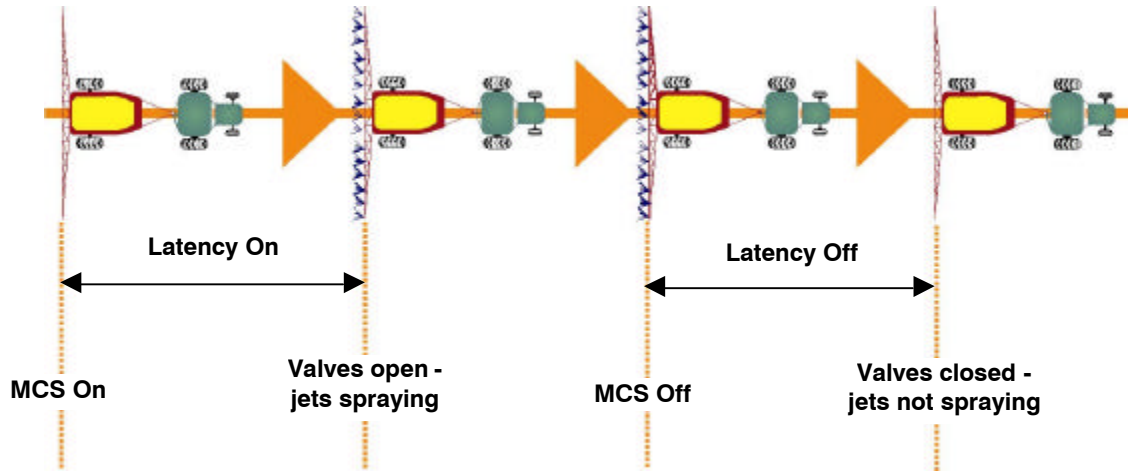

Figure 6: Latency values



3.5.8 Measuring Latency

The quickest way to estimate the latency of the sprayer is to use a stop watch, turn a spray section on and time the delay between this action and when spray come out of the nozzle onto the crop. These observations require precise timing and would need to be repeated many times to confirm that the times were accurate. The times would need to be measured to less than 0.01 of a second for precise control.

For a more accurate measurement, use the following procedure:

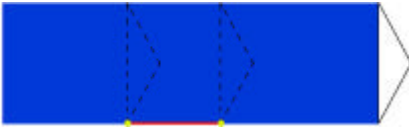
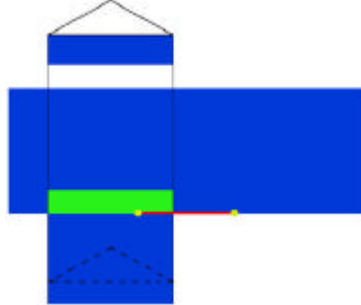
Step	Instruction	Diagram
1	<p>Drive slowly in a straight line down the field for 200m with the sprayer on. The tank should have water only for the purpose of this exercise.</p> <p>Have another person mark the end nozzle of the boom with two pegs and a rope half way along the spray run.</p>	 <p>The diagram shows a blue rectangular sprayer boom with a white arrowhead at the right end. A red line is drawn along the bottom edge of the boom, representing a spray run. Two yellow dots are placed on this red line, one near the left end and one near the right end, representing the end nozzle. Dashed lines indicate the spray pattern extending from the nozzle.</p>
2	<p>At right angles to the previous spray run, spray at 20km/hr across the spray mark with one end of the boom crossing over the rope.</p> <p>Ensure that you have allowed enough distance before crossing over the line for the boom trailer to straighten up behind the tractor.</p> <p>Have someone measure the distance from the rope to where the sprayer actually turned on the sections.</p>	 <p>The diagram shows the sprayer boom from the previous step crossing over the red spray run at a right angle. The boom is now oriented vertically, and the red spray run is horizontal. A green rectangular area is highlighted on the boom, representing the spray section that has turned on. The yellow dots from the previous diagram are still visible on the horizontal spray run.</p>
3	<p>Metric Calculations</p> <p>Forward speed in kph</p> <p>Distance (m) = The distance from the rope to where the sprayer turned on the sections, in <i>metres</i>.</p> <p>Calculate the latency using this formula:</p> <p>Latency (s) = Distance (m) ÷ Speed (km/h) x 3.6</p> <p>For example : Assuming the operator was travelling at 20km/hr and the distance from the rope to where the sprayer reacted is 5 metres:</p> <p>Latency(s) = 5(m) ÷ 20(km/h) x 3.6 = 0.9 seconds.</p>	
4	<p>Imperial Calculations</p> <p>Forward speed in mph.</p> <p>Distance (ft) = The distance from the rope to where the sprayer turned on the sections, in <i>inches</i>.</p> <p>Calculate the latency using this formula:</p> <p>Latency (s) = Distance (in) ÷ Speed (mph) x 0.056</p> <p>For example : Assuming the operator was travelling at 10mph and the distance from the rope to where the sprayer turned on the sections, is 150 inches:</p> <p>Latency(s) = 150 (in) ÷ 10 (mph) x 0.056 = 0.8 seconds</p> <p>Often the latency time for the sprayer to switch on will differ from the time to switch off. Currently a compromise needs to be made and averaging the two results is the best figure to use.</p>	
5	<p>Repeat steps 1 to 3, altering the 'Latency On' figure by plus or minus 0.1 seconds, until the optimum result is achieved.</p>	



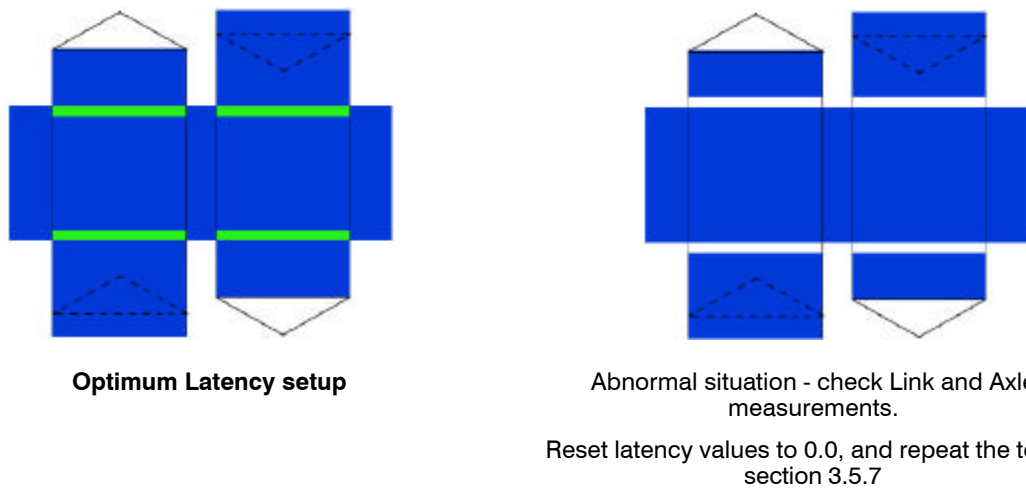
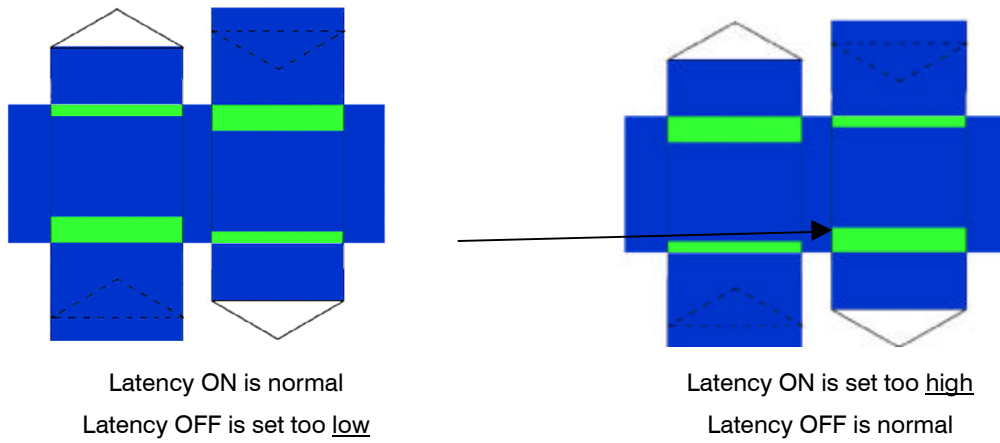
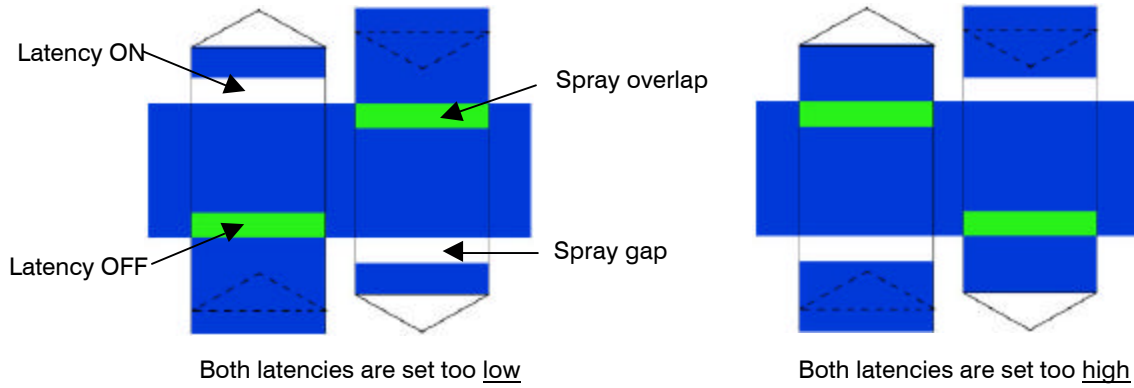

To calculate the 'Latency Off' value the same procedure is followed, except that the measurements are observed where the sections are switched Off crossing into the sprayed area.

The following examples show possible scenarios and how to resolve the latency settings for optimum control of the ASC 200.

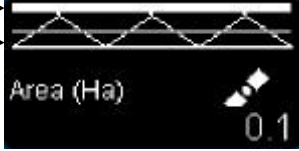

Record the spray parameters including latency settings, in section 3.6 for future reference.

3.5.9 Testing the Voltage Switch cable

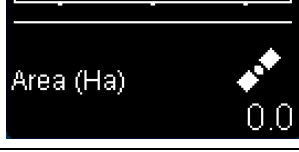
Step	Instruction	Screen
1	Start the ASC 200 using the On/Off button. The ASC 200 will start into the Operational mode after about 15 seconds and the display panel will appear as shown.	
2	Switch the SRC Master switch ON. If the vehicle is stationary the display will not change.	
3	If the vehicle is moving, with GPS connected. The MCS status will be On, and the Section status will be On as shown, (assuming three boom sections).	<div style="display: flex; align-items: center;"> <div style="margin-right: 10px;"> <p>MCS Status →</p> <p>Section Status →</p> </div>  </div>
4	If number of boom sections is more than 13, the displayed will be as shown.	
5	Switch the SRC Master switch OFF.	

A delay may occur between the switching of the Master Section switch and when the Master Status is displayed on the ASC 200. This delay is due to the type of electrical circuit switching used within the SRC.

If the display panel status value does not change, check that the Voltage Switch cable has been installed correctly.

3.5.10 ASC 200 'Self Test'

Prior to using the ASC 200 for the first time, perform a 'Self-Test' to ensure that all components are correctly installed and operational. The 'Self-Test' determines that the ASC 200 is communicating correctly with the SRC. It starts with a sound test and then turns each section On for three seconds.

To start the test, set the 'Self-Test' option to "Yes".

The left most boom section (when looking from behind the boom in a forward direction) will come on first. When the section test is finished it tests the MCS for general switching On and Off.

NOTE: If the MCS is set to External, it should be turned 'On' prior to starting the self-test.

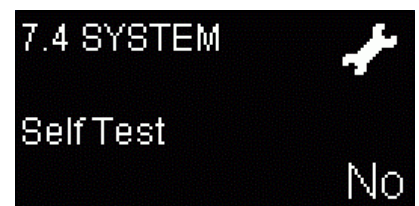

3.5.11 Testing the ASC 200 in the field

The second part of the test will require the spray rig to be in a field where the boom spray can be operated in a typical manner.

Step	Instruction
1	Start the ASC 200 using the On/Off button. The ASC 200 will start into the Operational mode after about 15 seconds.
2	Turn the spray rate controller ON. All boom section switches are to be in the OFF position.
3	Turn the spray rate controller Master switch to the ON position.
4	Drive the vehicle forward in a straight line and observe that all boom sections automatically switch ON. If the sections do not switch ON, check that all cabling is correct.
5	<p>Drive the vehicle around so that it crosses the portion of the field sprayed, and observe that all sections of the boom switch OFF and ON in the correct order (fig. 5a).</p> <p>If the sections all switch ON and OFF in the correct order, the field test have been successfully completed.</p> <p>If the sections do not switch OFF in the correct order, then check the cabling.</p> <p>The sections may not switch OFF at exactly the correct location, as the boom spray parameters may still require tuning (ref. section 3.5 – ‘Latency’).</p>
6	The ASC 200 system should now be tuned for the boom spray parameters as noted in section 3 5.

Figure 5a : Testing ASC 200 in field

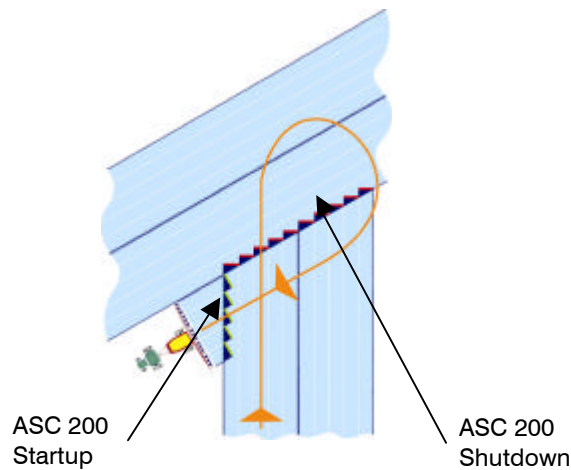

3.6 Measuring Vehicle and Boom Offsets





The ASC 200 models the movement of the entire spray rig, whether it is a self-propelled sprayer or a trailed sprayer. This allows the true position of the spray boom and its orientation, to be accurately computed for precise control when switching the boom sections ON and OFF.

3.6.1 Link and Axle Distances

The Link and Axle distances are used when determining the path of the spray rig as it moves around the field. The distances should be measured as follows (also ref. figs. 7, 8):

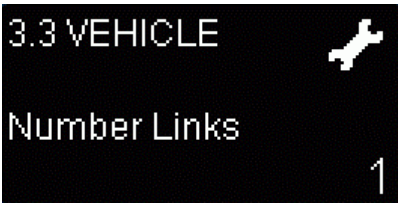
Link Setting	Measurement
Link 1	Link 1 is measured from the front axle centreline to the vehicle hitch point.
Axle 1	Axle 1 is measured from the rear axle of Link 1 to the hitch point of Link 1.
Link 2	Link 2 is measured from the hitch point of Link 1 to the hitch point or the flow point if it is the last link. (ref. figure. 7, 8)
Axle 2	Axle 2 is measured from the rear axle of Link 2 to the pivot point of Link 2.
Link 3	Link 3 is measured from the hitch point of Link 2 to the flow point. (ref. figure. 8)
Axle 3	Axle 3 is measured from the rear axle of Link 3 to the flow point.

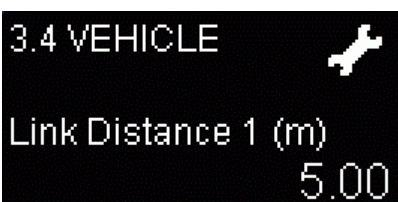
The number of Links and the Link and axle distances can be edited in the 'Vehicle' Menu.

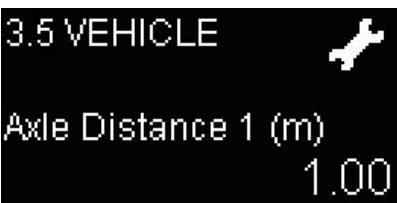
- (i) First edit the number of links for the spray rig.  
- (ii) Then edit the distances for each link.  
- (iii) Then edit the distances for each axle.  

NOTE: Record the settings in the appropriate section 3.6.2 – 3.6.6 for future reference.

3.6.2 Measurements - Tractor with trailed sprayer

Figure 7

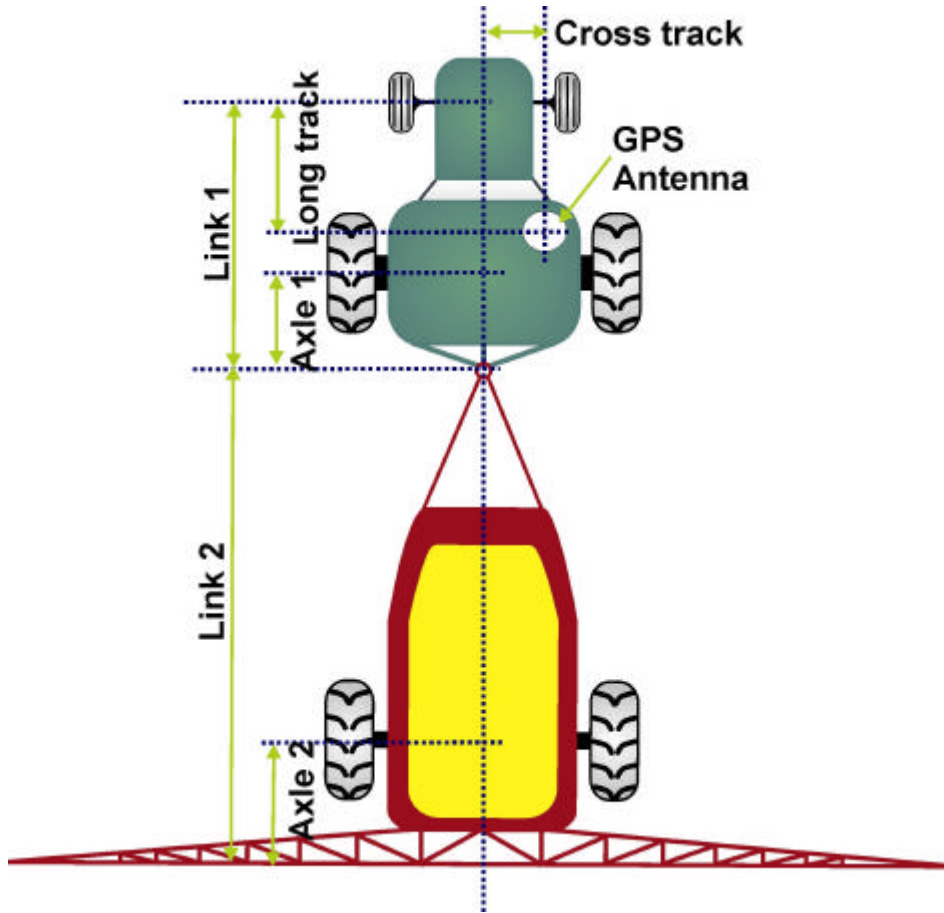

Vehicle Measurements

Number of Links	2		
Link 1		Axle 1	
Link 2		Axle 2	
Front Boom	NO	Mid Offset	0
Cross track		Long track	

Boom Details

Number of Sections			
Section 1		Section 2	Section 3
Section 4		Section 5	Section 6
Section 7		Section 8	

Boom Spray Parameters

Master Source (MCS)			
Latency On		Latency Off	
Tolerance		Min Delay	

3.6.3 Measurements - Tractor with trailed tank and sprayer

Figure 8

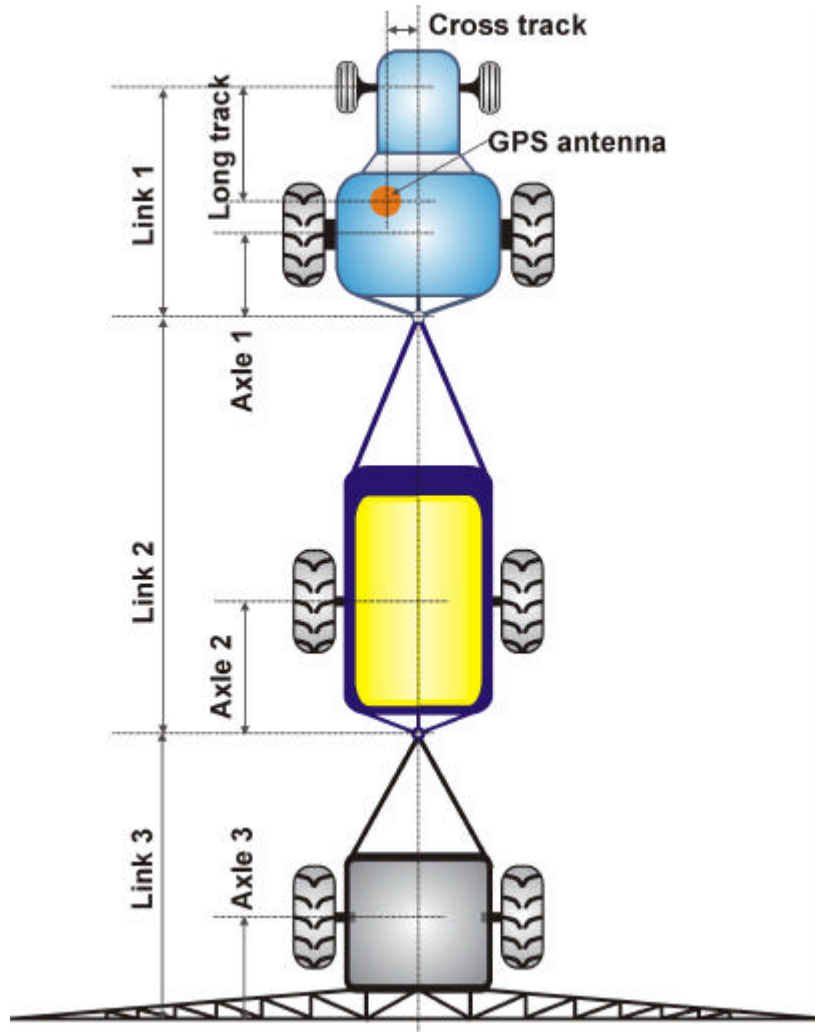

Vehicle Measurements

Number of Links	3		
Link 1		Axle 1	
Link 2		Axle 2	
Link 3		Axle 3	
Front Boom	NO	Mid Offset	0
Cross track		Long track	

Boom Details

Number of Sections			
Section 1		Section 2	Section 3
Section 4		Section 5	Section 6
Section 7		Section 8	

Boom Spray Parameters

Master Source (MCS)			
Latency On		Latency Off	
Tolerance		Min Delay	

3.6.4 Measurements - Self-propelled sprayer – rear-mounted boom

Figure 9

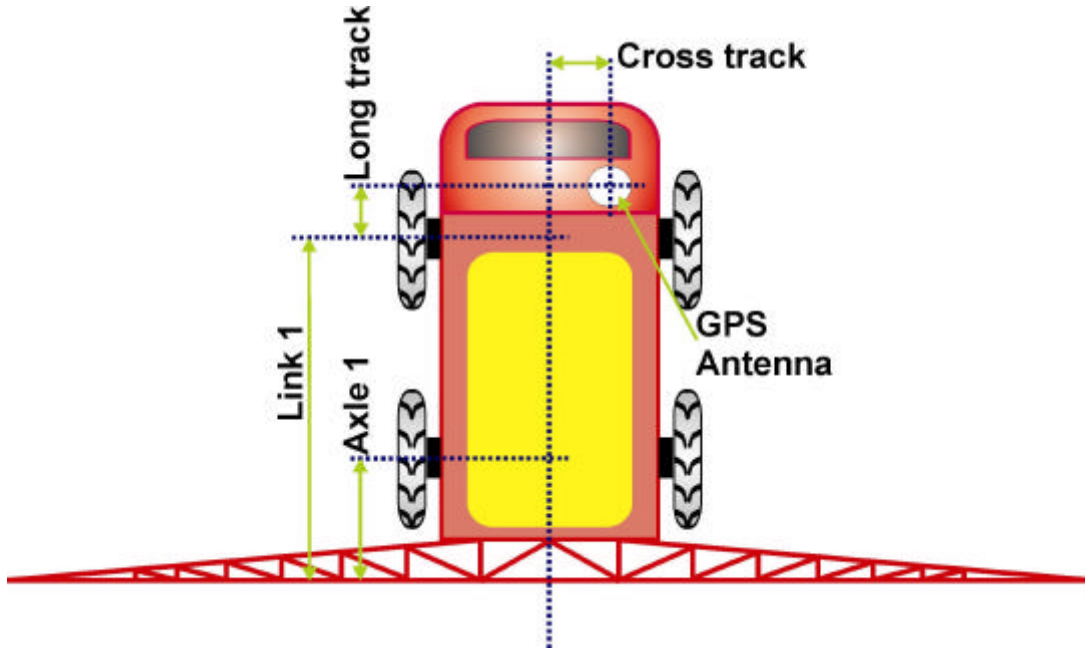

Vehicle Measurements

Number of Links	1		
Link 1		Axle 1	
Front Boom	NO	Mid Offset	0
Cross track		Long track	

Boom Details

Number of Sections			
Section 1		Section 2	Section 3
Section 4		Section 5	Section 6
Section 7		Section 8	

Boom Spray Parameters

Master Source (MCS)			
Latency On		Latency Off	
Tolerance		Min Delay	

3.6.5 Measurements - Self-propelled sprayer – front-mounted boom

Figure 10

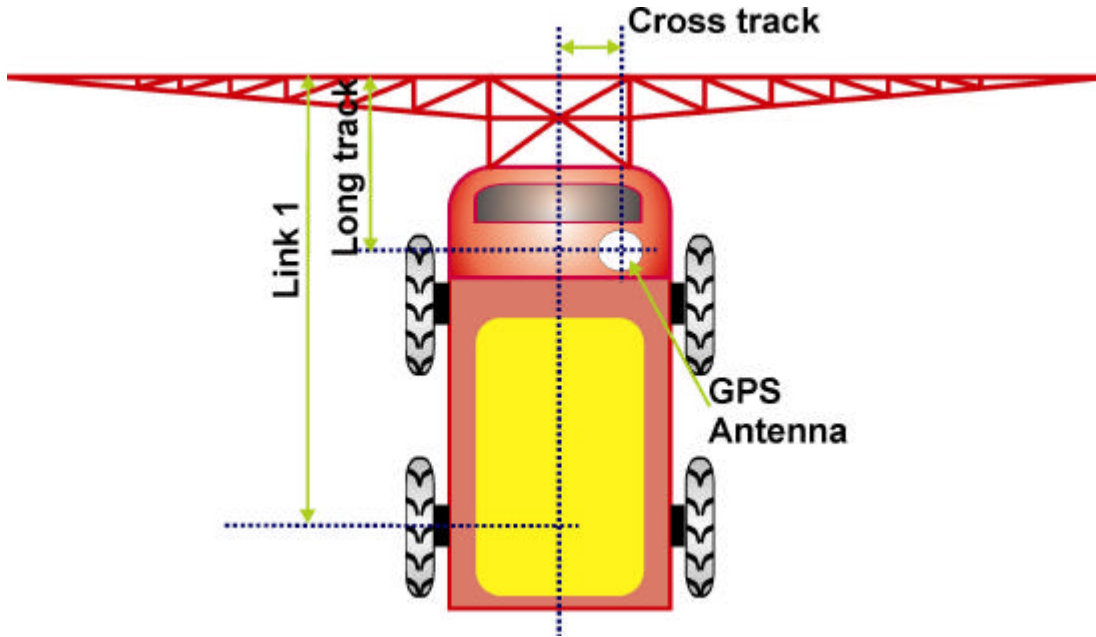

Vehicle Measurements

Number of Links	1		
Link 1		Axle 1	0.00
Front Boom	YES	Mid Offset	0.00
Cross track		Long track	

NOTE: Ensure that the Front Boom is set to 'YES' in the Vehicle Menu.

Boom Details

Number of Sections			
Section 1		Section 2	Section 3
Section 4		Section 5	Section 6
Section 7		Section 8	

Boom Spray Parameters

Master Source (MCS)			
Latency On		Latency Off	
Tolerance		Min Delay	

3.6.6 Measurements - Self-propelled sprayer – Mid-mounted split boom

Figure 11

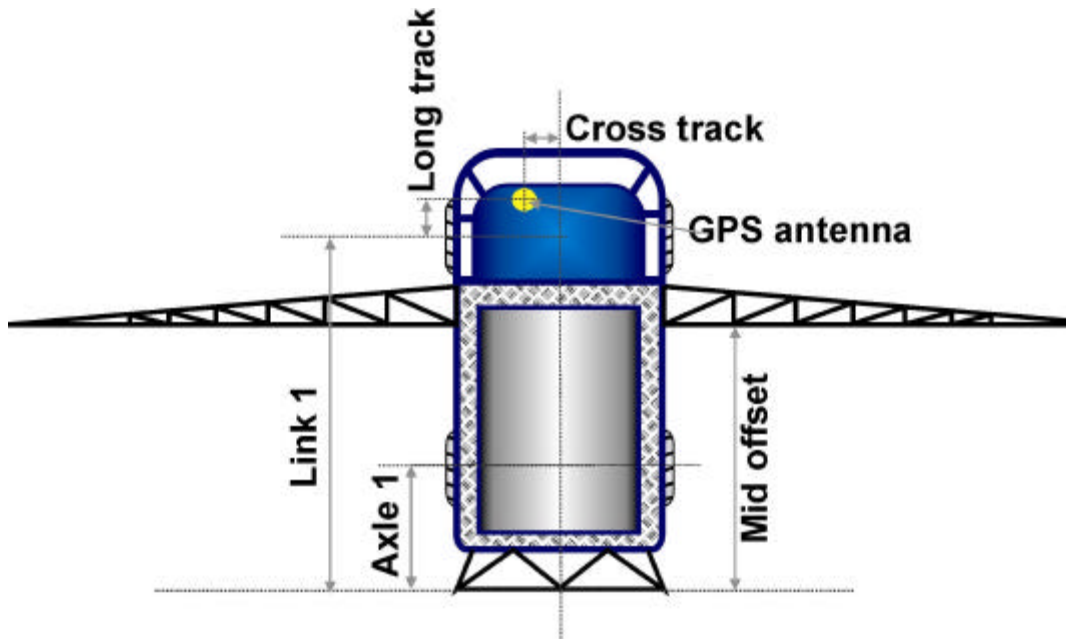

Vehicle Measurements

Number of Links	1		
Link 1		Axle 1	
Front Boom	NO	Mid Offset	
Cross track		Long track	

NOTE: Ensure that the Front Boom is set to 'YES' in the Vehicle Menu.

Boom Details

Number of Sections			
Section 1		Section 2	Section 3
Section 4		Section 5	Section 6
Section 7		Section 8	

Boom Spray Parameters

Master Source (MCS)			
Latency On		Latency Off	
Tolerance		Min Delay	

4. Using the ASC 200

Once the ASC 200 has been setup and calibrated it is a very simple system to use and requires only one button to start and stop operations in the field.

This section provides the user with a step by step guide to using the ASC 200 on a daily basis in the field. Should it be necessary to suspend or pause operations in the field, this section also describes the necessary steps.

While ASC 200 does not require user intervention during normal operation, the method of overriding the ASC 200 is also described in this section.

4.1 Some points to remember before you start

(i) **Ensure all the manual section switches on the sprayer switchbox are OFF.**

With the manual section switches OFF, the ASC 200 has full control switching sections ON and OFF. However if any manual section switch is ON, it will effectively override the ASC 200 'off' command.

(ii) **While reversing into position, switch the MCS OFF.**

The ASC 200 computations assume a *forward* speed. The maths is complicated, but if you don't switch the MCS OFF, you may spray the area twice that you reversed over.

(iii) **With the MCS ON, the sprayer will not spray while stationary.**

With the ASC 200 in control and the MCS ON, the ASC 200 needs to register a forward speed before it will switch sections ON. When you need to operate the sprayer while stationary e.g. for calibration purposes, switch the ASC 200 OFF to resume manual control via the sprayer switchbox.

4.2 Starting a Field

Prior to starting in a new field, it is essential that the ASC 200 has been setup and all relevant dimensions of the spray rig have been measured and recorded as shown in Section 3.6. It is also necessary that the system has been calibrated in accordance with Section 3.5.

Once these steps have been completed, then the system is ready for use in the field. Prior to starting the field, it is recommended the system is cleared of all previous information.

The first step is to start the vehicle and any necessary pumps or ancillary equipment in preparation for the field activities. The next step is to power up the ASC 200 and the SRC installed in the vehicle. The field data can then be cleared using one of two methods.

4.2.1 Clearing a Field from Operational Mode

This method is the quickest method to clearing all treatment data from the ASC 200 in preparation to commence a new field.

While in Operational mode, HOLD down the  button on the display panel for a few seconds until the screen displays "Clearing...".



The message "Treatment Clear" will be displayed when the field has been successfully cleared.

NOTE: All previous treatment data will be lost when the field is cleared.

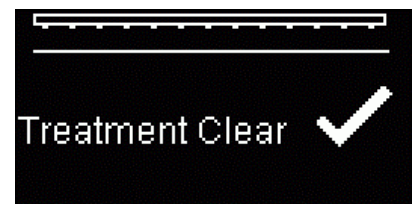





4.2.2 Clearing a Field from Setup Mode

The field can be reset in the Setup Mode by navigating to the menu '1.1 GENERAL-Field Reset', and then toggling the option to 'Yes'.

From the Operational Mode, with the MCS Off, press the  button to enter Setup Mode.

Navigate to the menu '1.1 GENERAL-Field Reset'.

Press the  button to enter EDIT mode, and press the  or  buttons to change the 'NO' to a 'YES'.

Press the  button to exit EDIT mode. The field will be cleared, as shown above.

4.3 Using the ASC 200 to Spray a Field

The following is a step-by-step guide to using the ASC 200 to spray a field using automatic boom section control.

Step	Instruction
1	If not already done so, start the vehicle and any necessary pumps or motors to operate the boom spray. Start the SRC and the ASC 200
2	Wait until the display panel is operational, this may take approximately 15 seconds. Confirm that the GPS status icon on the display panel shows the scrolling satellite. If the GPS is not ready wait until the system is ready to proceed.
3	Confirm that the Area value reports 0.0 ha for a new field. If the field has not been cleared, see Section 4.2.
4	Position the vehicle ready to commence spraying operations with the boom spray in position ready to drive forward to spray the field.
5	Turn all boom section switches to the Off position.
6	If the Master Switch of the SRC is not set as the MCS, then turn to the 'On' position, otherwise proceed to the next step.
7	Turn the MCS to the 'On' position. Note that MCS status will become a solid block at the top of the display panel.
8	Start to move the vehicle forward and observe that the boom sections will automatically switch On. The physical spray nozzles will start spraying the field. NOTE: See also section 4.4 – 'Forced Start'
9	Drive around the field in the normal method at the desired speed. As the vehicle moves over any area that has been sprayed the ASC 200 will switch Off boom sections as necessary to minimise over-spray in the field.
10	As the field is being treated, status information can be viewed on the display panel.
11	When the field has been completed, turn the MCS Off. NOTE: See also section 4.4 – 'Forced Start'
12	If the MCS is the keypad switch on the ASC 200, then also switch the Master Switch on the SRC to the 'Off' position.

NOTE: Boom sections will switch off if the vehicle is stationary with the MCS Off, unless the 'Forced Start' function is enabled (ref. section 4.4).

Once the field has been completed, the area of the field is displayed in the Operational Mode. The area is computed using GPS co-ordinates, hence it may not agree exactly with the SRC, as it will typically use a relatively coarse calculation based upon the distance travelled.

4.4 'Forced Start' (Section Control)

Under normal conditions, the sections are switched off when the vehicle forward speed is below 0.8 km/h (0.5 miles/h). With the MCS switched on, the sections will not start spraying until the forward speed threshold is reached.

The 'Section Control' function when enabled, forces the sections to remain on even if the vehicle is stationary. This is useful when the vehicle has to manoeuvre into position and instant application is required when the MCS is switched on.

'Forced Start' is enabled ('1'), or disabled ('0') via the 'GENERAL' menu in Setup mode.

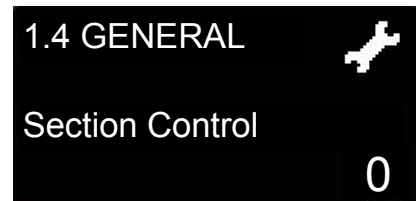

'0' All sections are switched Off when the forward speed goes below 0.8 k/hr (0.5 miles/h).

'1' All sections are forced On (when the MCS is switched On) even when the vehicle is stationary.

4.5 Suspending & Resuming Spraying Operations in the Field

Simply stop and switch the MCS Off to suspend spraying. You can then move off the field e.g. to refill the tank.

As long as the treatment data is not cleared from memory, simply return to the previous position and switch the MCS ON to resume spraying. Spraying operations can be resumed in the field after any period of time, assuming that the treatment has not been cleared from the ASC 200. However it should be noted that the accuracy of the shut-off will be related to any drift in GPS accuracy over this time.

NOTE: To continue tank agitation on the spray rig without auto section control, place the ASC 200 in Setup Mode and turn the MCS On.

4.6 Starting a New Field

To spray a new field, it is recommended to first clearing the existing treatment data from memory (refer back to section 4.3 if necessary).

Clearing information from the ASC 200 ensures that the internal memory is not overloaded with old data from completed fields. The ASC 200 has a capacity to work in fields up to 2,000 ha.

4.7 Override Function

The Override Function is used to override the status of the system, so that selected sections are temporarily fixed to 'On' or 'Off' and are not controlled by the ASC 200.

To use overrides, first the function must be enabled and set to either 'On' or 'Off' in Setup mode. Thereafter, the individual sections to be overridden can be selected and deselected in Operational mode, while spraying.

The Override function is configured using the PARAMETERS menu in Setup mode.

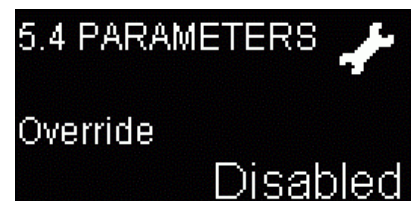

NOTE: Override Function is accessible only after turning the MCS On.

Override Status	Action
Disabled (Default)	Used to switch the Override Function off. In this state the Override is not active and the user is not able to manually control the section switches.
Off	Allows the user to manually switch boom sections (sequentially from the left or right side) to 'Off' and ignore the ASC 200 status.
On	Allows the user to manually switch boom sections (sequentially from the left or right side) to 'On' and ignore the ASC 200 status.
Manual	Allows the user to manually switch individual boom sections On or Off and ignore the ASC 200 status.

4.7.1 Overriding sections ON or OFF sequentially from the left or right

The override can start from either the left or right hand side.

To use 'Override' while spraying, press the  and  buttons while in Operational mode, to select sections.

Press  to select and deselect sections starting from the left end of the boom, working to the right with each subsequent press.





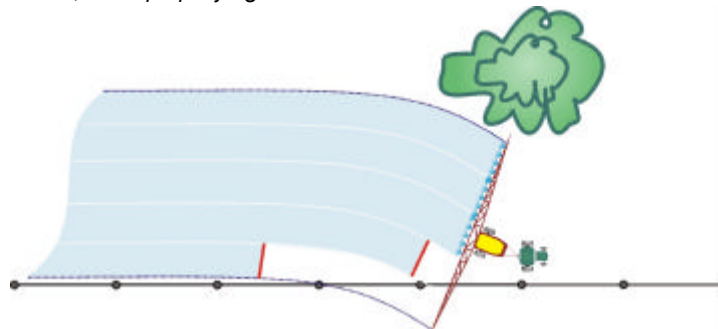

Press  to select and deselect sections starting from the right end of the boom, working to the left with each subsequent press.

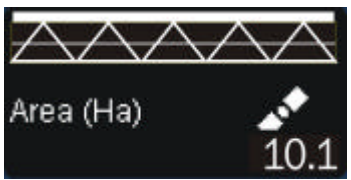

As an example assume that it is necessary to spray around an obstacle, and one side of the boom will pass across to an adjoining field, which is not to be sprayed as shown in figure 12.

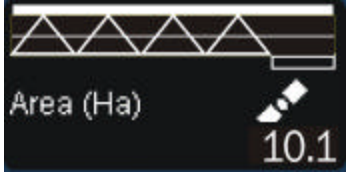
Figure 12: Manual Override to Off, to stop spraying over a fence line

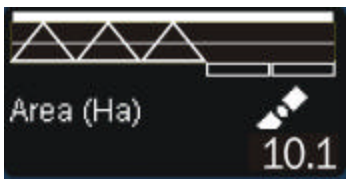

Using manual override allows the user to manually switch sections 'Off' (ref. Note 2), on the outer end of the boom, as it extends over the boundary that is not required to be sprayed. This is shown in the following steps;

STEP	Screen	Boom Spray
Normal mode		All boom sections are On and the 'Override' function is not activated 
Press 		The outermost, right hand boom section is 'Off'. The manual override indicator status is shown below the section switched Off. 
Press  again		The two outermost, right hand boom sections are 'Off'. The manual override indicator status is shown below the two sections switched Off. 

The above actions can be reversed by pressing the  or  button as required, or pressing the  will clear all override settings and the ASC 200 will function as normal.

NOTE 1: If the MCS setting is configured as 'Keypad' then it is not possible to clear the override setting using the switch .

NOTE 2: Setting the 'Override' status in the SETUP menu to 'On', means that using manual override, allows the operator to manually switch sections 'ON' instead of 'OFF'.

The Override status indicator then appears as a solid bar as shown here.

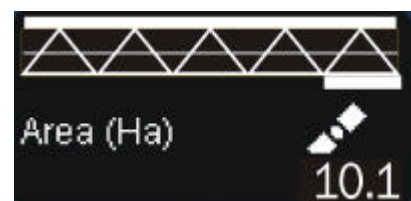



4.7.2 Overriding all sections ON or OFF

If the MCS is external, (i.e. it does not utilise the ASC 200 keypad), then all sections can be overridden ON or OFF by simply pressing the  switch.













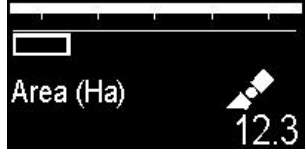

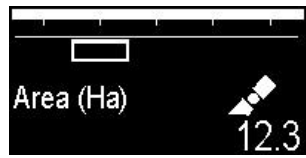
Simply press the  switch again to clear the override function.

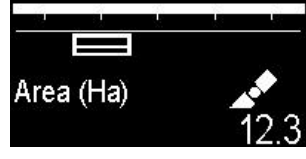
4.7.3 Overriding individual sections ON or OFF

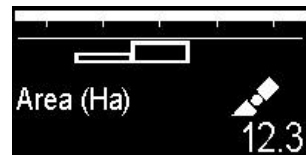
The 'Section Control' setting in the Setup menu must be set to 'Manual'.

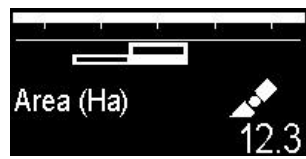
Press  as required, to select the section that you want to override. Press  as required, to toggle between Override Off, Override On and Automatic (no override).

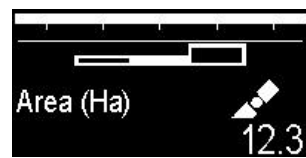
Example:

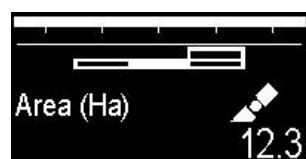
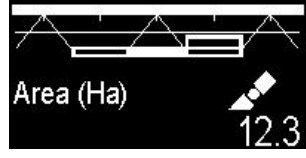
Step	Description	Result
1	Press  and  while in Operational mode, to select sections. Flashing box indicates the current section (1) to be configured.	
2	Press  to select next section (2).	
3	Press  to select Override Off (shown).	
4	Press  to select next section (3).	
5	Press  twice to select Override On (shown).	
6	Press  to select next section (4).	
7	Press  to select Override Off (shown).	
8	Switch MCS on to start spraying. Sections (1) and (5) are in Automatic mode, section (4) and (4) are set to Override Off, and section (3) is set to Override On.	



5. The Menu System



This section describes how to navigate the menus, and shows the complete menu structure for reference.

5.1 Navigating the Menus

The ASC 200 has two modes of operation. Navigation in each mode is slightly different, and is explained below.

Operational Mode



Use the  and  buttons to view the various information available to the operator while spraying.

Use the  and  buttons to override boom sections (if the Override function is enabled in the SETUP menu).

Use the  button to change to Setup mode.

Setup Mode

Use the  and  buttons to change menus.

Use the  and  buttons to select an option within a menu.

Use the  button to enter and exit Edit mode. Edit mode is used to change the value of a menu item.





While editing the value of items, use the  and  buttons to change the highlighted value, and use the  and  buttons to select the character under the highlight.



Use the  button to change to Operational mode.

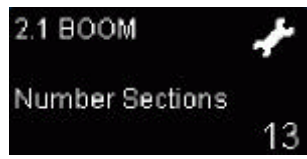

Navigation Example

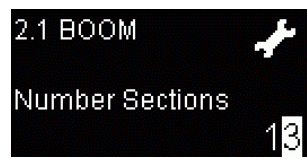
The following is an example of how to change the number of boom sections, starting from the default Operational mode display.

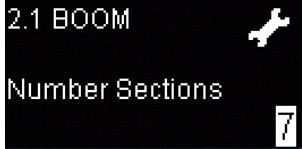
NOTE: Ensure that the MCS is Off.

Step	Action	Result
1	Press  to change to Setup mode.	
2	Press  to move to the BOOM menu.	
3	Press  to enter EDIT mode	

4	Press  to decrease the value.	
5	Press  to exit EDIT mode and save the new value.	

NOTE: Setup mode cannot be entered when spraying. To change the digit being edited, press the  and  buttons until the correct digit is highlighted.

5.2 The Menu Structure

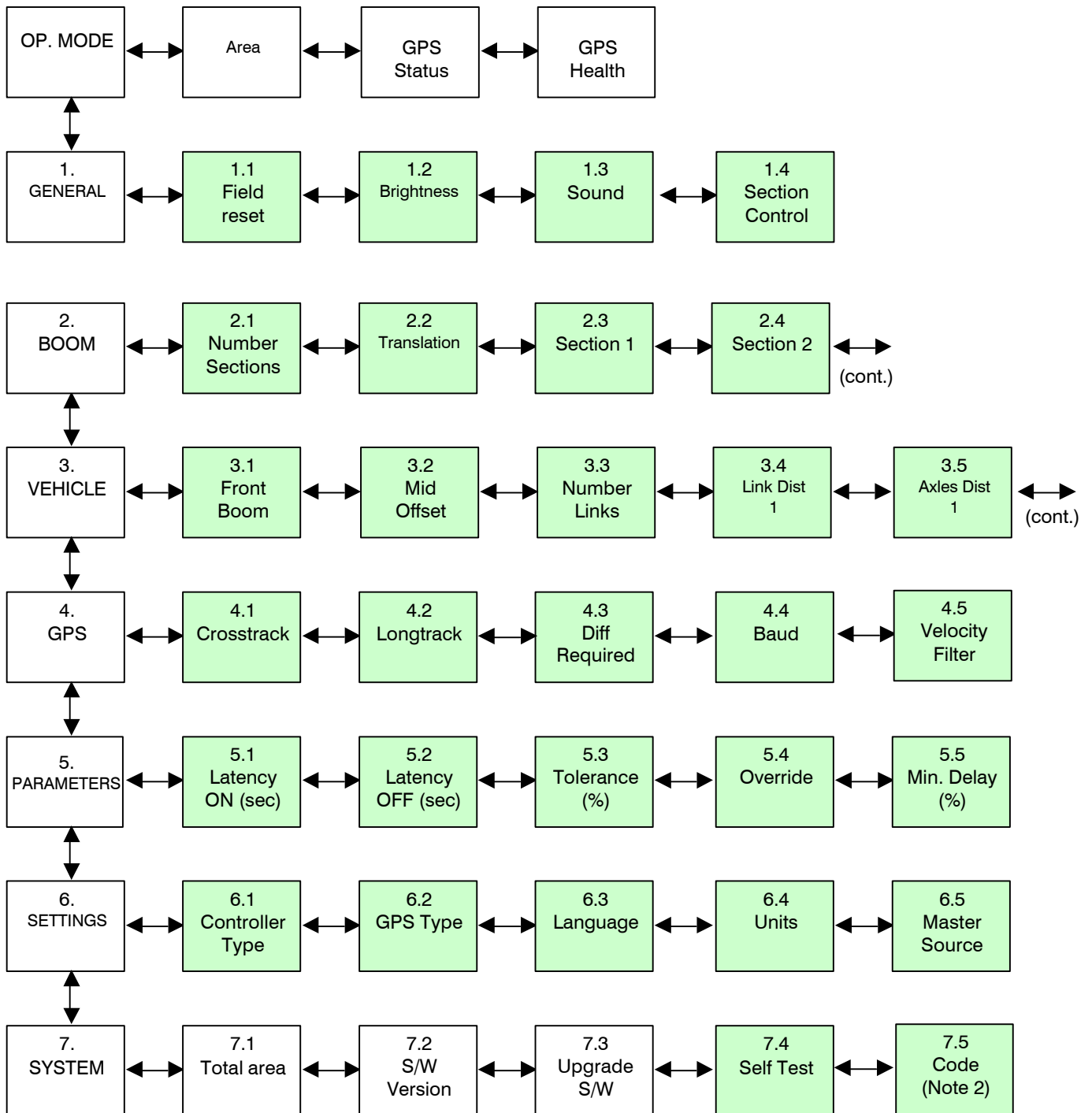

NOTE 1: Menu Items shaded can be edited when not spraying.

NOTE 2: 'Code' setting allows selection of different control algorithms. Default = 0. Do not change unless advised.

6. Appendices

Appendix 1 - System Messages

System messages will display when an event or error occurs. Please record any message, in case technical support is then required.

Message	Meaning
Turn Master Off	The MCS must be turned off before this function can be selected.
Clearing...	The current treatment is being cleared.
Treatment Clear	The current treatment has been successfully cleared.
Upgrading...	The system software is being upgraded.
Upgrade Complete	The system software has been successfully upgraded.
Error: copying	An error occurred copying a file to or from the USB drive.
Error: rename	An error occurred when upgrading the software.
File not found	The file to upgrade was not found on the USB drive.
Please Reboot	Please shut down and restart the system after changing baud rate or upgrading the software.
Width too large	The total width entered for the boom sections exceeds the maximum allowable width (100m)
Soft Reset	A soft reset is being performed.
Hard Reset? No Yes	Do you want to perform a hard reset? Press arrow key beneath your choice.
Reset Failed	The reset failed.
Reset Complete	The reset completed successfully.
Loading...	The system is loading the current field.
Disk Full	Disk space is full. Clear the field.
Memory Full	All available memory is used. Shut down and restart the ASC 200.
Max Cells Reached	The maximum number of cells for storing data has been reached. Clear the field.
Exiting...	The system is preparing to turn off.
Error...Power Outage.	The system has detected that the input power has dropped below minimum requirements. Use the IPS to turn off and restart the ASC 200.

Appendix 2 - Resetting the System





Soft Reset

Performing a 'Soft Reset' will clear all treatment data from the system prior to the program starting.

Hard Reset



Performing a 'Hard Reset' will clear all treatment data from the system and reset all settings back to factory defaults.

To either 'Soft Reset' or 'Hard Reset' the system, proceed as follows:

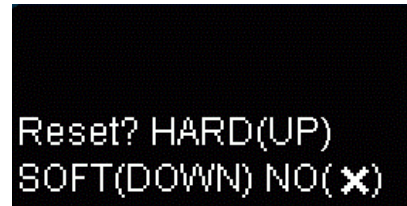
1. Turn the system ON and press and hold down the  button on the display panel until a beep is heard.
2. Release the  button immediately. The display should now be at the 'Reset' menu as shown.
3. Press the  arrow key to access the 'Soft Reset' menu, or, press the  arrow key to access the 'Hard Reset' menu,



The ASC 200 now requires confirmation to complete the reset as shown.

4. Press the  key to confirm the request for a reset, or press the  key to cancel the reset operation.

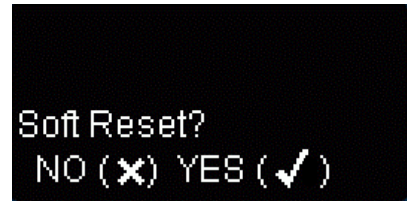

After a 'Soft Reset' has been performed, "**Reset Complete**" will be displayed and the software will continue to start with all treatment data cleared.

After a 'Hard Reset' has been performed, "**Reset Complete**" will be displayed and the software will continue to start with treatment data and all parameters cleared.

NOTE: *It will be necessary to re-enter all setup parameters back into the ASC 20 after a 'Hard Reset'.*

The 'Reset' menus are in English only.



Appendix 3 - Troubleshooting

The ASC 200 is a robust system and should provide many years of trouble free service. In the unlikely event that something is not correct, please check the following points before contacting your local dealer for service.

Problem	Probable Cause	Action
Boom sections do not switch OFF	Incorrectly wired No GPS signal Boom section switches are ON 'Tolerance' setting too low Master Control Switch (MCS) incorrectly set	Check wiring Check that GPS is being received Turn section switches OFF Check settings on 'Tolerance' (3.5.6) Check settings for Master Control Switch (MCS)
Boom sections switch at the wrong time	GPS is inaccurate 'Latency' settings are set incorrectly	Check with the GPS supplier Check latency settings (3.5.7)
NO GPS signal	No NMEA data Incorrect GPS settings Incorrect GPS cable GPS connected to wrong port	Check that the connected GPS is turned ON and working Check GPS settings match the GPS receiver Check that the correct GPS cable is being used. Check that the GPS cable is connected to the correct port.
Boom sections do not switch OFF	Incorrect cabling Incorrect 'Miss Tolerance' settings Incorrect MCS settings	Check that the SRC data cable is properly connected to correct port. Check settings for 'Miss Tolerance' (3.5.6) Check settings for MCS
ASC 200 will not power up	Isolation switch (IPS) is OFF Incorrect cabling	Turn the Isolation switch ON The ASC 200 has not been correctly installed - check power supply.
ASC 200 will not save settings after restart	Unit not shut down correctly Incorrect cabling	Switch the ASC 200 off in the correct way The ASC 200 has not been correctly installed. Check and rectify.
ASC 200 is very slow to respond	The last data file may be corrupt	Perform a 'Soft Reset' as denoted in Appendix 2. A 'Hard Reset' should only be done as directed by an authorised technician
It is difficult to read the display panel	Unit switched off Check the 'Brightness' setting	Check that the ASC 200 is switched on. Increase the 'Brightness' setting
The ASC 200 alarms are not heard.	The Sound option in the General menu is set to 'No' Check that the speaker enclosure is not covered	Set the 'Sound' option in the 'General' menu to 'Yes'. Remove any obstructions from the speaker
Warning message that the Master Switch cannot be switched OFF	The MCS is 'ON' Incorrect cable in GPS port and settings for the MCS	Turn the MCS 'OFF' Check that the GPS cable is the one supplied with the ASC 200

System constantly beeps	No GPS	Check that the GPS is correctly configured and connected to the ASC 200
System beeps randomly	GPS dropping out	Check GPS antenna and cables for corrosion and/or damage. Check the 'GPS Health' message
"File Not Found" message when upgrading software	Insufficient time to recognise upgrade media	Wait 30 seconds and then retry the upgrade operation.
System does not respond to bi-pole switch operation.	Setting for MCS is incorrect Bi-pole switch connection is incorrect	Set the MCS option to 'Bipole' Check that the bi-pole switch is connected to the Section Controller Port
ASC 200 does not respond	Power fluctuation	Restart ASC 200 using the Isolation power switch (IPS)
"Error – Zone Problem" reported	Invalid GPS position in data	Clear existing treatment data by pressing and holding the  button
The 'Area' value is too low compared to SRC	Area reported by ASC 200 is "Covered Area" The SRC may be calculating area differently, by not accounting for overlapping swaths.	Invalid comparison Note that 'Treated Area' reported by ASC 200 only includes area sprayed <u>once</u> .

Appendix 4 - Connector Pin-Outs

Ports A and B Connectors

Port 'A' is a full RS-232C serial port. Port 'B' is a basic RS-232C serial port.

The pin functions are shown below.

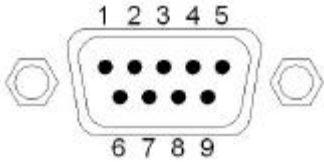
Connector Pin Locations	Pin	Port A I/O	Port B I/O	Signal
	1	-	-	Not Connected
	2	IN	IN	Receive data (RxD)
	3	OUT	OUT	Transmit data (TxD)
	4	OUT	-	Data terminal ready (DTR)
	5	-----	-----	Data ground
	6	IN	-	Data set ready (DSR)
	7	OUT	-	Request to send (RTS)
	8	IN	-	Clear to send (CTS)
	9	-	-	Not connected

Power Input Connector

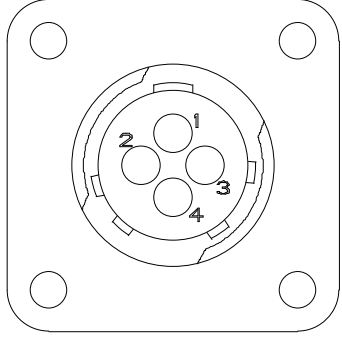
Connector Pin Locations	Pin	Host I/O	Signal
	1	IN	Battery Negative
	2	IN	Vehicle Ignition sense input <i>(Not available with cable supplied)</i>
	3	IN	Optional battery feed for high current applications <i>(Not available with cable supplied)</i>
	4	IN	Battery Positive

Section Controller Connector

This connector allows the ASC 200 to interface with external boom section valves.

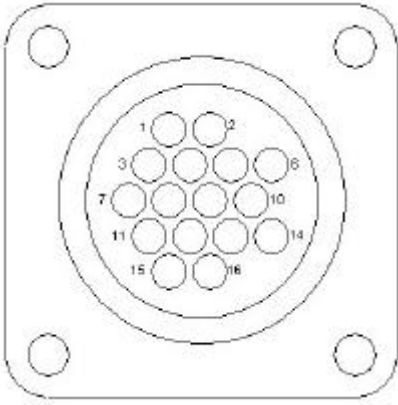
Connector Pin Locations	Pin	Host I/O	Signal
	1	-	+12 V
	2	-	0 V
	3	OUT	Section 1
	4	OUT	Section 2
	5	OUT	Section 3
	6	OUT	Section 4
	7	OUT	Section 5
	8	OUT	Section 6
	9	OUT	Section 7
	10	OUT	Section 8
	11	IN	Master Switch
	12	OUT	<i>(Not available with cable supplied)</i>
	13	OUT	<i>(Not available with cable supplied)</i>
	14	OUT	<i>(Not available with cable supplied)</i>
	15	OUT	<i>(Not available with cable supplied)</i>
	16	OUT	<i>(Not available with cable supplied)</i>

Appendix 5 - Specifications

Weight:	500grams
Size:	183 (w) x 104 (d) x 57 (h) mm
Environment:	Casing: Aluminium extrusion, environmentally robust and shock resistant Operational: 0° to +50°C (32°F to 122°F) Non-operational: -20° to +60°C (-4°F to 140°F)
Data I/O:	Electrical interface: ASCII serial / CANBus Plug types: D-9 male (Serial) x 2 D-9 male (CANBus) x 1 USB x 1 AMP 16pin male (Section Controller Port) AMP 4 pin male (Power supply)
Power:	12VDC Nominal / 8 – 16VDC , 2A max.
Output:	No. of Sections: 30 sections (max via serial data cable) 8 sections via Voltage Switch cable Pt No. S/CBL/381-1-005 (1-2805)

Document History

Issue 1	22/10/07	Original issue (re-formatted from document version 1.0 Rev. A)
Issue 2.0	23/2/09	Reference source document version 1.1 Rev. A p.29, section 4.3 – changes p.30, section 4.4 – added, section 4.7 - changes p.32, section 4.7.3 – added p.35, section 5.2 - changes