

### **Electro-Magnetic Compatibility (EMC)**

This product complies with Council Directive 2004/108/EC when installed and used in accordance with the relevant instructions.



### **Service and Technical Support**

PLEASE CONTACT YOUR NEAREST DISTRIBUTOR  
If unknown then fax: 44 (0) 1453 733322

© Copyright RDS Technology Ltd 2005

Document number

S/DC/500-10-505 : Issue 1 : 7/2/05

\\UK505-1.DOC

# **User Guide**

## **Athene 200 Fertiliser Spreader Monitor/ Variable Rate Controller**

Operation

Software Reference WZ814-000 rev.5

# Contents

- 1 Overview 4**
  - 1.1 System components..... 4
  - 1.2 The Head Unit and work measurement functions ..... 5
  - 1.3 Switch Functions - Summary ..... 6
  - 1.4 Instrument On-Off / Work Status Indication ..... 7
  - 1.5 Channel Selection..... 7
  - 1.6 Starting and Stopping the Spreader..... 7
- 2 Rate Control 8**
  - 2.1 Under-application (excessive speed) ..... 8
  - 2.2 Setting the Target Base Rate ..... 8
  - 2.3 Spot Application - Nudging the Target Rate ..... 9
- 3 Product Calibration 10**
  - 3.1 Calibration Procedure..... 10
  - 3.2 FAQ's about Product Calibration ..... 12
  - 3.3 Correcting the Calibration Factor..... 13
    - 3.3.1 Adjusting the "T" Factor ..... 13
- 4 Other Work Measurement Functions 14**
  - 4.1 Forward Speed ..... 14
    - 4.1.1 Low Speed Alarm..... 14
    - 4.1.2 High Speed Alarm (Under-application)..... 14
  - 4.2 Area ..... 14
    - 4.2.1 Select Area Total 1 or Area Total 2 display ..... 15
    - 4.2.2 Reset Area Total 1 or Area Total 2 display ..... 15
  - 4.3 Work Rate ..... 16
  - 4.4 Spinner Speed ..... 16
    - 4.4.1 Spinner Underspeed Alarm ..... 16
  - 4.5 Hopper Contents- Display options ..... 17
    - 4.5.1 Low Level Alarm (using Hopper Level Sensor) ..... 17
    - 4.5.2 Weight display (Quantity left in hopper/ Quantity dispensed)..... 17
  - 4.6 The "Quantity remaining in Hopper" display ..... 18
    - 4.6.1 Resetting the "Hopper Maximum Quantity" figure ..... 18
    - 4.6.2 Set Alarm Quantity ..... 18
    - 4.6.3 Adjusting the "Hopper Maximum quantity" figure ..... 19

4.7 “Quantity Dispensed” display..... 20  
4.7.1 Resetting the “Quantity Dispensed” display to Zero ..... 20

# 1 Overview

## 1.1 System components

The instrument provides variable rate control of a twin shutter fertiliser spreader, by controlling two linear actuators to operate the traps. Here are the components of the control system.

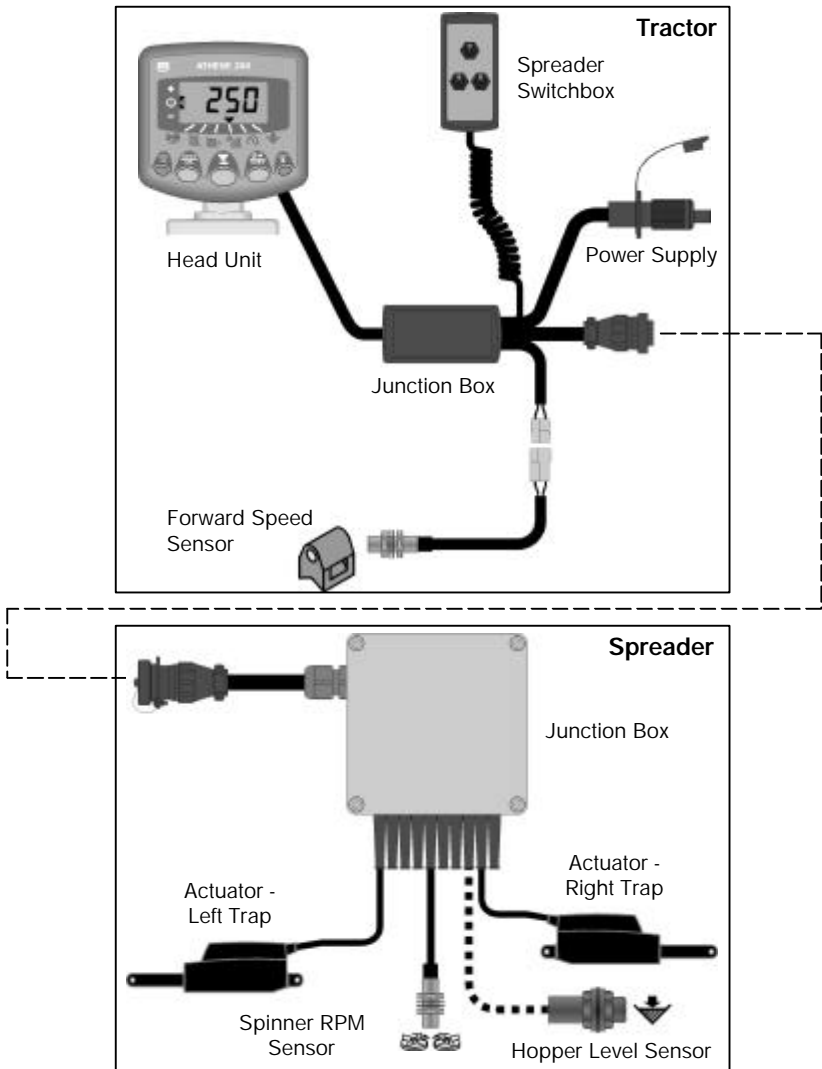

This manual explains the everyday use of the *Athene 200* Monitor/Controller to the operator, including regular calibration e.g. for spreading different products. Other calibration settings are explained in the calibration manual (ref. RDS Pt No. S/DC/500-10-455).

## **1.2 The Head Unit and work measurement functions**

The head unit is ruggedly designed for maximum reliability in harsh environments, and is rated to IP67 (effectively waterproof). The instrument has a 4-digit back-lit LCD display with 6 display channels for different work measurement functions.

In the normal operating mode the following functions are displayed,

- Forward Speed (km /hr)
- Area Worked\* (hectares)
- Work Rate (hectares /hr)
- Application Rate (kg/ha or tonnes/ha) or RPM depending on the application
- Spinner RPM
- Hopper Contents (kg or tonnes)

\* There are two memory registers to record area worked. The area is accumulated to whichever total is selected on the display – 'Total 1' or 'Total 2'.

The head unit is switched on and off by the switch on the back the instrument.

Area totals (and all calibration data) are automatically stored in memory when the instrument is powered off.

### 1.3 Switch Functions - Summary

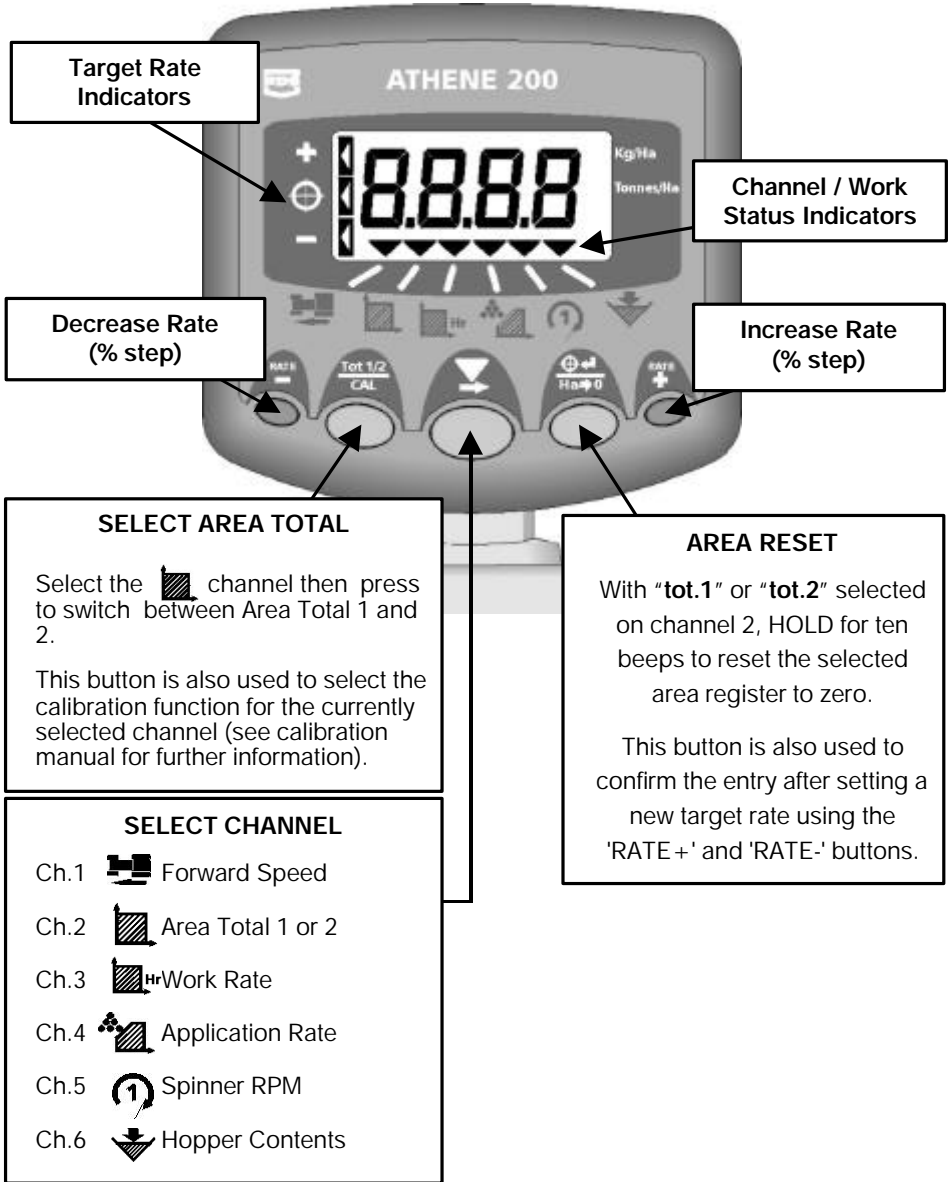

## 1.4 Instrument On-Off / Work Status Indication

The power on-off switch is located at the rear of the instrument.

The ▼ indicator indicates the channel to which the figure on the display relates. It also shows the working status of the spreader.

The cursor flashes when the spreader is 'out of work' (e.g. on the headland), and the area accumulation stops.

The cursor is on continuously when the spreader is 'in work', and area accumulation takes place.

## 1.5 Channel Selection

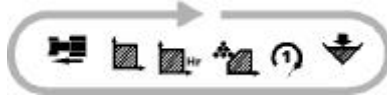

Simply press the ▼ button to cycle through the work measurement display functions. The instrument will always default to the application rate display 10 seconds after selecting any other channel (the exception to this is when there is an alarm condition).

## 1.6 Starting and Stopping the Spreader

The spreader is started and stopped via the separate switchbox, not from the head unit.

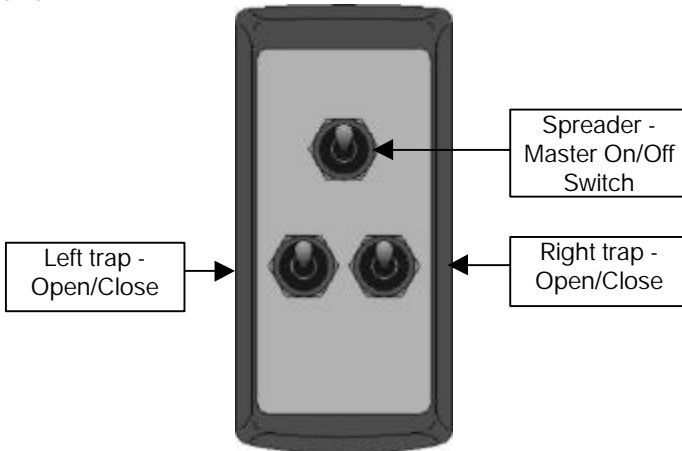

NOTE: If either trap is closed for half-width spreading, area automatically accumulates at half-rate on the instrument.

## 2 Rate Control

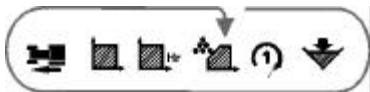

In normal operation, i.e. in work and in the absence of any alarm conditions, the instrument will display on this channel the calculated application rate (kg/ha).

NOTE: When out of work (and stationary) the target rate is displayed.

A target base rate is programmed by the operator. For spot application, this base rate can be adjusted up or down in % steps as required while the system is in work. The instrument will control the actual application rate to meet the target rate irrespective of the forward speed.



Note however, that the forward speed range over which the system can meet the target rate will depend on the rate set. If the forward speed is too high or too low, the instrument will alert the operator with an audible alarm.

### 2.1 Under-application (excessive speed)

If your forward speed exceeds the maximum beyond which the target application rate cannot be achieved (i.e. the actuator(s) have reached their maximum extension), then the instrument defaults to a flashing forward speed display and beeps continuously. You must reduce your forward speed sufficiently for the target rate to be maintained, at which point the instrument will stop beeping and return to the application rate display.

### 2.2 Setting the Target Base Rate

The target base rate can only be set with the spreader out of work and stationary.

1. Select the  channel and the base rate is displayed.
2. Then press and hold either the  or  buttons to adjust the rate up or down.



The display will briefly show the %step size by which the target rate can be nudged when in work, before the target rate begins to change.

**NOTE:** The longer you hold either button the more rapidly the target rate will change. To make smaller adjustments, release the button and then make single presses to adjust the rate in 1kg increments.

3. Press the  button to confirm the new target rate setting.

### 2.3 Spot Application - Nudging the Target Rate

You can adjust the application rate up to 50% above or below the target rate whilst in work.

Press the  or  button to nudge the rate up or down by a pre-programmed % (5% by default).

**NOTE:** Refer to the calibration manual to set the % step size.

The bar on the left side of the display indicates when you are above or below the target rate. When nudged above or below the target rate the application rate display will flash, alternating between the new application rate and the % nudge e.g. if a target rate of 500 kg/ha is nudged minus 5%, the display will then alternate between '475' (kg/ha) and '-5'.

-5% below target

At target

+5% above target



Press  to return to the target rate.

### 3 Product Calibration

To ensure that the system applies the correct quantity of fertiliser, requires the operator to perform a bucket test for each fertiliser type. The instrument has a bucket test mode for this purpose.

**The bucket test can only be performed with the spreader out of work (the ▼ indicator must be flashing) and the vehicle stationary.**

#### 3.1 Calibration Procedure





1. Remove the left disc and prepare the bucket to collect the dispensed fertiliser.
2. Place the fertiliser to be tested in the hopper.
3. Enter the 'bucket test' mode ('CAL.3' mode) by pressing the  switch whilst turning the power on.

The instrument displays the simulated forward speed (default = 8 km/hr) that will be used during the test. If required, this can be modified to represent the typical operating speed using the  switch.

4. Press the  switch to move to the next channel to set a simulated area.

This is the area over which the product calibration test will be simulated. There are 3 options to choose from depending on the intended application rate and bucket size

Intended application rate (kg/ha)	Display	Simulated Area (ha)
0-100	'bAJA'	0.4
100-300	'NOR'	0.13
300-800	'ALtA'	0.05

5. Press the  switch to select the desired option and move to the next channel to set the target application rate.
6. Enter the target rate using the  and  switches. Press  to confirm and select the next channel.
7. The display will show 'disc' indicating to the operator to run the PTO at the normal speed to ensure the agitation is working correctly above the metering outlet. Once the spinner speed is detected the instrument will flash '0000'.

**NOTE:** If you are performing calibration tests for an extended period, there is a possibility that fertiliser can become compacted and overheat above the closed right hand trap, due to there being no material flow.

**Therefore you are advised that during extended bucket testing, to ensure that the right hand side remains empty of fertiliser.**

8. Open the left trap using the switch box and the actuator will extend to the required position to satisfy the rate and speed previously set, based on the current 'T' factor.

The display will show 'run'. It will remain open until the programmed area has been simulated, where upon it will close automatically irrespective of the switch box. The display will then show 'stop'.

9. Stop the PTO. When the instrument registers that the shaft speed is zero the instrument will then display the message 'trAp' until the left actuator switch is returned to the 'off' position. No switches will function until this is done after which the display will flash the theoretical expected weight.

10. Weigh the contents of the bucket.



11. Adjust the weight displayed using the  and  switches to match the amount weighed from the bucket. Press  to confirm and select the next channel.

12. The instrument displays the newly calculated 'T' factor and you should record this in the manual for future use. This value will overwrite the factor in programming mode 1, channel 4. If the newly calculated value is outside the limits 0.800 -1.200, then the display will show 'Err1', indicating that the test must be repeated.

13. Press  to repeat the test from step 3, or turn the instrument off and on again to return to normal operating mode.

14. Re-fit the left disc ready to go spreading.

### 3.2 FAQ's about Product Calibration

Possible cause	Remedy
<b><i>There is a small discrepancy in the amount applied.</i></b>	
The tank surfaces have surface corrosion, which reduces material flow.	As the surfaces become polished by material flow during normal use, you may need to adjust the "T" factor (3.3).
The flow characteristics of the fertiliser are different to that used for calibration.	The fertiliser may have absorbed more moisture than the material used in the bucket test, so you may need to adjust the "T" factor (3.3).
Normal variations such as field conditions, humidity, nature of product etc.	Adjust the "T" factor (3.3).
<b><i>There is a big discrepancy in the amount applied.</i></b>	
The programmed spread width is incorrect.	From normal operating mode, select the  channel, then press and hold  to view width setting.
The forward speed is incorrect due to incorrect calibration.	Perform an 'AutoCal' (refer to calibration manual).
No forward speed signal.	Check wiring connection of forward speed sensor. Check that the magnet passes within 10 -15mm of the sensor.
<b><i>The instrument beeps continuously</i></b>	
Forward speed too high.	The beeping indicates that the control parameters have been exceeded, and so the application rate set cannot be met. As a result the actual quantity dispensed will be less than it should be. Simply reduce your speed.

### 3.3 Correcting the Calibration Factor

If after spreading in the field, you find a consistent discrepancy between the instrument weight reading and the actual weight dispensed, then calculate a corrected "T" factor using a simple formula and re-programme it.

A corrected factor can be determined by a simple calculation using the actual weight and the displayed weight as follows :





$$\text{Corrected factor} = \text{Programmed factor} \times \frac{\text{Actual weight}}{\text{Displayed weight}}$$

For example: The existing factor is 0.904. The displayed weight was 780 kg but the actual weight dispensed was 1000kg.

The "T" factor needs to be set as  $0.904 \times (1000/780) = 1.158$

Therefore, if the weight displayed on the instrument is more than the actual weight dispensed, the "T" factor must be *decreased*, and if the weight displayed on the instrument is less than the actual weight dispensed, the "T" factor must be *increased*.

#### 3.3.1 Adjusting the "T" Factor

1. While in the normal operating mode, select the rate channel (  ).
2. Press and hold the  switch for 3 seconds. The existing "T" factor then flashes on the display.
3. Adjust the figure up or down using the  or  switches.
4. Press the  button again to return to the normal operating mode.

## 4 Other Work Measurement Functions

### 4.1 Forward Speed



The forward speed is displayed in km/hr.

#### 4.1.1 Low Speed Alarm

If the forward speed drops below 0.5 km/hr while the spreader is operating (i.e. material is flowing out of the trap(s)), the instrument defaults to a flashing forward speed display and the instrument beeps 5 times every 30 seconds.

The instrument will return to the application rate display when forward speed increases above 0.5 km/hr.

#### 4.1.2 High Speed Alarm (Under-application)

This alarm is activated when, as a result of too high a forward speed, the actuator is required to extend further than its maximum extension, and consequently the target rate cannot be met. The instrument defaults to a flashing forward speed display and beeps continuously.

The instrument will return to the application rate display only when forward speed is reduced sufficiently for the target rate to be met.

### 4.2 Area



The area (in hectares) is derived from the forward speed (or the simulated speed for the calibration test) and the programmed implement width. Area will only accumulate when the spreader is switched on and either one or both traps are open. If one trap is closed, then area accumulates at half rate. There are 2 memory registers - 'Total 1' and 'Total 2' and area accumulates to both of them. These totals can be independently reset to zero.

### 4.2.1 Select Area Total 1 or Area Total 2 display



1. Select the  channel.
2. Press  to cycle between the two area totals.  
*The display will then show 'tot.1' or 'tot.2' before displaying the area accumulated since that total was last reset*



Figure 4: Select Area Total

### 4.2.2 Reset Area Total 1 or Area Total 2 display



1. Select the  channel.
2. Press  to cycle between the two area totals.
3. Hold  for 5 seconds to zero that total.



Figure 5: Reset Total 1 / Total 2

**NOTE:** A grand total area (non-resettable) can be viewed in the calibration mode (refer to the Calibration manual).

### **4.3 Work Rate**



The work rate is displayed in ha/hr.

The work rate is derived from the working width set and the forward speed. It is based on the currently selected area register 'Total 1' or 'Total 2' (therefore there are 2 work rate registers).

The work rate is updated each time the system registers 'out of work' (i.e. the spreader is switched off).

### **4.4 Spinner Speed**



This channel displays the r.p.m. of the spinner. Within the normal operating range, the spinner speed is displayed to the nearest 10rpm.

*NOTE: This channel cannot be selected if the spinner sensor cal factor is set to zero in calibration mode 2 (refer to the calibration manual).*

#### **4.4.1 Spinner Underspeed Alarm**

If the spinner speed drops below a user-programmed threshold (default = 400rpm), instrument will default to the spinner rpm display and will beep 5 times every 30 seconds. You can temporarily ignore the alarm by selecting another channel.

The instrument will return to the application rate display when the spinner speed is restored above the threshold.

If the spinner speed registers zero, the traps are automatically closed and the instrument display flashes '**diSc**'. Starting the spinner will cancel the display message and enable the traps to be opened.

The low speed alarm threshold is set in calibration mode 2 (see calibration manual).

## 4.5 Hopper Contents- Display options

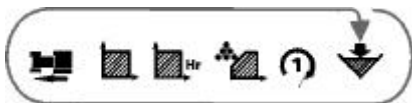

This channel gives either a simple low level alarm or displays the hopper contents, depending on how the system is configured.

### 4.5.1 Low Level Alarm (using Hopper Level Sensor)

If the hopper is fitted with a level sensor, when you select this channel it will briefly display “1” to indicate that the alarm is enabled, and then display nothing.

**NOTE:** This is the default setting. If “0” is displayed then the alarm is disabled.

When the hopper contents fall below the sensor, the display will default to this channel and flash “**Alar**”, and the instrument will beep 5 times every 30 seconds. You can temporarily ignore the alarm by selecting another channel.

The hopper level alarm does not function when the forward speed is less than 2km/hr.

### 4.5.2 Weight display (Quantity left in hopper/ Quantity dispensed)

The instrument must be set for “Volumetric” hopper contents in the calibration mode (if necessary, refer to the calibration manual).



Based on the application rate, the system calculates the theoretical quantity in the hopper, displaying either the total weight dispensed or the quantity remaining in the hopper, depending on how the instrument is configured in the calibration mode.

If kg units are selected, the units are kgs up to “9999” thereafter the decimal point indicating the readout is in tonnes (to the nearest 10kg) e.g. 10.10 tonnes.



### 4.6 The “Quantity remaining in Hopper” display

If the Hopper Maximum Quantity is set to a value above zero in the calibration mode (refer to the Calibration Manual to set this), the display will *count down from the maximum figure*, showing the quantity of product remaining in the hopper. When the calculated weight reaches the pre-programmed hopper alarm-weight, the instrument will sound 5 beeps every 30 seconds.



#### 4.6.1 Resetting the “Hopper Maximum Quantity” figure

Select the  channel, then press and hold the  button. The instrument will give 10 beeps then resets to the default figure. The factory default setting is 2000kg.

#### 4.6.2 Set Alarm Quantity

1. Select the  channel, then press and hold the  button for 3 seconds

The current alarm quantity appears (fig 8a). The factory default setting is 250kg (0250).

2. Continue holding the  button.
3. PRESS and RELEASE the  button to select the digit or decimal point to change, or...
4. HOLD the  button to change the digit or move the decimal point.

Remember, setting a decimal point sets the units as tonnes. If no decimal point is set, the units are in kgs.

5. Release the  button to return to the normal operating mode.



Figure 8a: View Alarm quantity









Figure 8b: Set Alarm Quantity

**4.6.3 Adjusting the “Hopper Maximum quantity” figure**

The meaningfulness of the display is reliant on the Hopper Maximum Quantity being correctly programmed for the actual quantity of product in the hopper at the start.

You may well want to adjust the default figure (e.g. for a part-loaded hopper)

1. Switch the instrument off. Press and hold the  and switch the instrument on.
2. Press  to select the  channel. The maximum quantity then appears with the first digit flashing (fig.9a). You can now release the  button.
3. PRESS and RELEASE the  button to select the digit or decimal point to change, or...
4. HOLD the  button to change the digit or move the decimal point.  
Remember, setting a decimal point sets the units as tonnes. If no decimal point is set, the units are in kgs.
5. Switch the instrument off and then back on again to return to the normal operating mode.

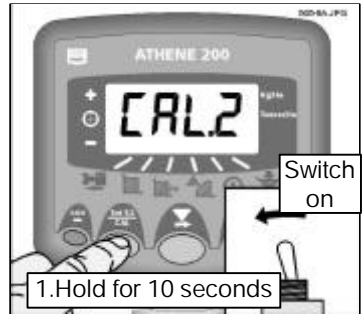

Figure 9a: View Hopper Maximum Quantity



Figure 9b: Set Hopper Maximum Quantity



When the spreader is put into work, the display will then continue counting down from the figure that has been entered above.

## **4.7 “Quantity Dispensed” display**

If the Hopper Maximum Quantity is set to zero in the calibration mode (see 4.6.3) , the alarm function is disabled and the display will *count up from zero*, indicating the quantity of product dispensed.

### **4.7.1 Resetting the “Quantity Dispensed” display to Zero**

You can reset to zero, e.g. if logging individual hopper loads, field totals, daily totals etc. Please note however, that aside from this channel total there is no independent “grand total” that stays in the instrument’s memory.

Select the  channel, then press and hold the  button. The instrument will give 10 beeps then reset to zero.





Issue 1 : 7/2/05 Original issue (based on S/DC/500-10-454)