

## Delta 34i Sprayer Controller Calibration

RDS Part No.:	S/DC/500-10-572
Document Issue:	2.00 : 17/6/09
Software Issue:	PS521-001 rev.17

## **Electromagnetic Compatibility (EMC)**



This product complies with Council Directive 2004/108/EEC when installed and used in accordance with the relevant instructions.

## **IMPORTANT, READ THIS BEFORE USING THE PS8000i**

The *PS8000i* installation is a part of the Precision Farming System ("the System"). It is very important that you follow the described calibration procedures before operating the *PS8000i* instrument. Calibration and operation of the *PS8000i* must be in accordance with these instructions. Use of the System is subject to the following disclaimer;

1. So far as is legally permissible RDS Technology ("RDS"), or its distributors, shall not be liable, whatever the cause, for any increased costs, loss of profits, business, contracts, income, or anticipate savings or for any special, indirect or consequential damage whatsoever (death or personal injury excluded).
2. The capabilities and functions of the Precision Farming System ("the System") are limited as set out in the specification of the System, details of which are contained in the Help files and product literature and which must be read before using the System.
3. Without prejudice to the generality of the above it is hereby acknowledged that the System is not designed nor intended to a) originate variable treatment plans or b) achieve or avoid any application rate outside application parameters, which in both cases shall be the responsibility of the operator.
4. The standard terms and conditions of RDS (except clause 7), a copy of which is available on request, apply to the supply and operation of this System.

## **Service and Technical Support**

PLEASE CONTACT YOUR NEAREST RDS DISTRIBUTOR if unknown then contact RDS Technology Ltd for further information,

Tel : +44 (0) 1453 733300

Fax : +44 (0) 1453 733311

e-mail : [info@rdstec.com](mailto:info@rdstec.com)

web : [www.rdstec.com](http://www.rdstec.com)

Our policy is one of continuous improvement and the information in this document is subject to change without notice. Check that the software reference matches that displayed by the instrument.

© Copyright RDS Technology Ltd 2009

\\UK572200.DOC

<b>INTRODUCTION</b>	<b>5</b>
<b>Selecting the Control Software</b> .....	<b>5</b>
<b>The "Setup" Screen page</b> .....	<b>5</b>
Calibration on installation	5
Calibration in normal use	5
<b>Data Entry</b> .....	<b>6</b>
<b>1     SENSOR CONFIGURATION MENU</b>	<b>7</b>
<b>1.1   Forward Speed Sensor</b> .....	<b>7</b>
1.1.1   Select Sensor Option	7
1.1.2   Wheel sensor calibration – ‘Autocal’	7
1.1.3   Wheel sensor calibration - manually calculating the Forward Speed Factor	7
1.1.4   Radar Sensor	8
1.1.5   RDS ‘Satspeed’ Interface / NMEA VTG Input	8
<b>1.2   Boom configuration</b> .....	<b>9</b>
1.2.1   Set number of Boom Sections	9
1.2.2   Set No. of Nozzles per section and Nozzle Spacing	9
<b>1.3   Selecting the Regulation Mode</b> .....	<b>9</b>
<b>1.4   Flow Sensor Setup</b> .....	<b>10</b>
1.4.1   Channel	10
1.4.2   Function	10
1.4.3   Sensed Width	10
1.4.4   Flow sensor Cal factor	11
1.4.5   Minimum flow and Maximum flow	11
1.4.6   Start Delay	11
1.4.7   Valve Type	11
1.4.8   Calibrating a Tank Filling Sensor	11
<b>1.5   Pressure sensor setup</b> .....	<b>13</b>
1.5.1   Function	13
1.5.2   Calibrate Pressure Sensor	13
1.5.3   Damping	13
<b>1.6   Configuring the Control Valve</b> .....	<b>14</b>
1.6.1   Response	14
1.6.2   Deadband	14
1.6.3   Startup Delay	14
<b>1.7   Alarms</b> .....	<b>15</b>
1.7.1   Setting the Alarm thresholds	15
1.7.2   MAX. SPEED and MIN. SPEED	16
1.7.3   MAX. FLOW and MIN. FLOW (Flow-based regulation only)	16
1.7.4   OFF TARGET	16
<b>1.8   Calibrating an RPM Sensor</b> .....	<b>16</b>
1.8.1   LOW / HIGH RPM ALARM	16

<b>2.</b>	<b>LIQUID CALIBRATION</b>	<b>17</b>
2.1	<i>Initial Calibration - using the "Nozzle Calibration Routine" .....</i>	<i>17</i>
2.2	<i>Full-Tank Calibration.....</i>	<i>19</i>
<b>3.</b>	<b>TECHNICIAN CONFIGURATION MENU</b>	<b>20</b>
3.1	<b>Display Options.....</b>	<b>20</b>
3.1.1	Speed Smoothing Factor	20
3.1.2	Rate Lock-On	20
3.1.3	Rate Smoothing	20
3.2	<b>Control Options.....</b>	<b>20</b>
3.2.1	Nudge Step Size	21
3.2.2	Off Target Alarm	21
3.2.3	SPEED RELATED: Options	21
3.3	<b>Boom Cutouts / Inputs.....</b>	<b>21</b>
	Master Cutout	21
	Boom Inputs	21
	Cutout	21
	Booms	21
3.4	<b>Print Calibration Data .....</b>	<b>22</b>
3.5	<b>Ports Setup.....</b>	<b>22</b>
3.6	<b>Change PIN for Technician Menu.....</b>	<b>22</b>
<b>4.</b>	<b>FACTORY CONFIGURATION MENU</b>	<b>23</b>
4.1	<b>Machine Options.....</b>	<b>23</b>
4.2	<b>Total Software Reset.....</b>	<b>23</b>
4.3	<b>Backing Up and Restoring Calibration Data .....</b>	<b>23</b>
4.4	<b>Change PIN for Factory Configuration Menu.....</b>	<b>23</b>
<b>5.</b>	<b>USER OPTIONS</b>	<b>24</b>
5.1	<b>Set Time and Date.....</b>	<b>24</b>
5.2	<b>Adjust Screen Contrast and Brightness .....</b>	<b>24</b>
5.3	<b>Set Units .....</b>	<b>24</b>
5.4	<b>Select Language .....</b>	<b>25</b>
5.5	<b>Select Control Software.....</b>	<b>25</b>
<b>6.</b>	<b>GENERAL PF SETUP</b>	<b>25</b>
<b>7.</b>	<b>THE SETUP MENU</b>	<b>26</b>
	Calibration routine .....	26

## Introduction

The instrument must be calibrated before commencing normal operation. Many settings are made only on initial installation e.g. from the 'SENSOR CONFIGURATION' screen. Other calibration settings may need to be altered on a regular basis according to the liquid being sprayed, nozzle types in use etc.

## Selecting the Control Software

With the purchase of an optional "software module" which comes in the form of an electronic chip loaded into the back of the instrument, the Pro-Series can be instantly switched to perform another function e.g. from a Sprayer Controller to a Data Logger for route navigation and soil mapping tasks. This is done from "Instrument Select" in the "USER OPTIONS" menu.

## The "Setup" Screen page

Press the  key to select the SETUP menu (fig. 1a).

Figure 1a

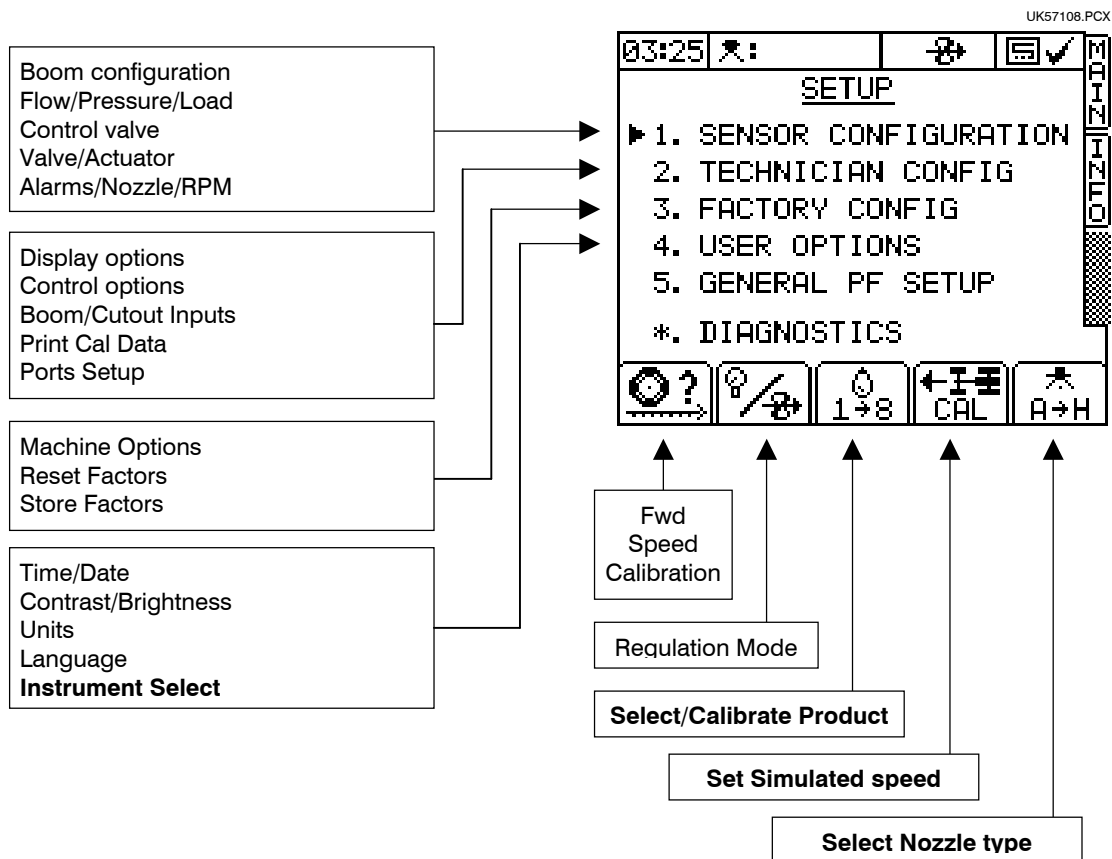

## Calibration on installation

Work through the 'SENSOR CONFIGURATION' menu first. Most of these settings need be done only once on installation.

## Calibration in normal use

Calibration settings that need to be accessed more frequently are highlighted in bold type on figure 1. These settings include;

- Product calibration
- Tank and Product selection
- Nozzle type
- Speed alarm

## Data Entry

Alpha-numeric values are entered via the right-hand keypad. You must press the key from 2 to 5 times to select the required letter. (Some keys have additional special characters not shown on the key legend).

The  key will either toggle between lower and upper case characters or when preceding a numerical entry, will set a MINUS value.

The  key will toggle between 0 and a SPACE.

The  key will BACKSPACE the screen cursor if you need to re-enter a character.

The  key is the RETURN key and is normally pressed to confirm the data entry into memory.

# 1 Sensor Configuration Menu

Calibrate the Forward Speed Sensor and Flow / Pressure Sensor before commencing liquid calibration.

## 1.1 Forward Speed Sensor

### 1.1.1 Select Sensor Option



- From the SETUP screen, press  to select the "SPEED FACTOR" screen (fig. 1b).

Figure 1b

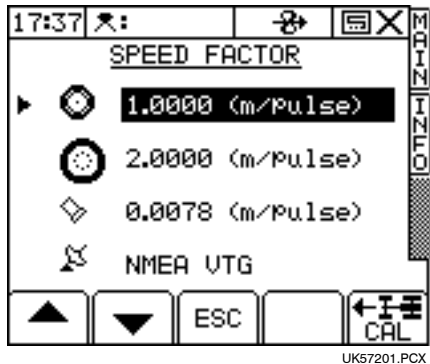

- ← Wheel Sensor - for flotation tyres
- ← Wheel Sensor - for (larger) row crop wheels
- ← Radar Sensor / RDS 'Satspeed' Interface
- ← DGPS input (this option only appears when top port is configured for GPS input)

- Move the arrow cursor to select the option and press  to confirm.

### 1.1.2 Wheel sensor calibration – 'Autocal'

If the sprayer has a standard wheel sensor and magnets installed, you can programme the instrument with two speed sensor factors - for flotation tyres and for row crop wheels. Remember to select the appropriate factor after changing wheels.

The Speed Sensor Factor ("SSF") is the distance travelled forward in the time between two pulses from the forward speed sensor. This could be calculated based on the nominal tyre diameter or rolling distance and then entered manually (ref. section 1.1.3), however this does not take into account wheel slip, compaction, or tyre deformation under practical operating conditions.

The best method is to do an "Auto Cal".

Mark a set distance of 100 metres (or 100 yards depending on the units set on the instrument) by suitable means. The surface should be representative of the average field conditions (i.e. not a paved surface). Position the vehicle with the first marker level with a suitable reference point on the vehicle.

With the appropriate [sensor option](#) highlighted on the "SPEED FACTOR" page, press ENTER, then select "Auto Cal". Press  and then follow the screen instructions.

Stop the vehicle when the second marker lines up with the pre-determined reference point on the vehicle and press  to end the "Auto Cal" procedure. The Speed Sensor Factor is automatically re-calculated and stored in memory.

**NOTE:** If you overrun the marker, do not simply reverse - repeat the "Auto Cal" procedure from the beginning.

### 1.1.3 Wheel sensor calibration - manually calculating the Forward Speed Factor

The smaller the speed sensor factor the better the speed update will be. Aim for a factor less than 2.000 m (78.78").

**NOTE:** Perform the following calculations in *inches* or *metres* depending on whether the instrument is set for Imperial or Metric units. If you calculate the factor using any other unit of measurement e.g. feet or centimetres, the forward speed display will be incorrect.

- If a single magnet is installed (as with a standard RDS Propshaft Sensor kit)**, the distance travelled for each turn of the prop shaft must be determined. To determine this distance, drive the vehicle forwards for exactly **10** revolutions of the prop shaft. Measure this distance (in inches or metres) and divide by **10**, to find the Speed Sensor Factor.

- (ii) ***If 2 magnets are installed (as with a standard RDS Wheel Sensor kit)***, the distance is 1/2 the effective rolling circumference of the wheel. To determine this circumference, drive the vehicle forward in field conditions (with the implement attached if applicable), for exactly **10** revolutions of the sensed wheel. Measure this distance (in inches or metres) and divide by **20** to find the Speed Sensor Factor.
- (iii) ***If 4 wheel magnets are installed***, the distance is 1/4 the effective rolling circumference of the wheel. To determine this circumference, drive the vehicle forward in field conditions (with the implement attached if applicable), for exactly **10** revolutions of the sensed wheel. Measure this distance (metres) and divide by **40** to find the Speed Sensor Factor.

Carry out this test whenever soil conditions or wheel sizes change.

If the calibration factor works out at over 2.000 m (78.78 inches), consider fitting additional magnets. Extra magnets are recommended if the vehicle has large diameter wheels or is slow-moving. In extreme circumstances you can find that the speed keeps going to zero as it times out before the next pulse arrives.

**Number of magnets required**

The table gives the number of magnets required to enable a speed update of approximately 1 Hz or greater on the display.

Tyre diameter	Typical speed in normal operation:		
	up to 5mph (8km/hr)	6 to 9 mph (9 to 15 km/hr)	10mph (16 km/hr) or over
12" (0.3m)	1	1	1
24" (0.6m)	1	1	1
36" (0.9m)	2	2	1
48" (1.2m)	4	2	2
60" (1.5m)	4	4	2
72" (1.8m)	4	4	2

**Example Calculation**

A vehicle is fitted with a single magnet mounted on the propshaft. The measured distance for 10 rotations of the sensed wheel is 47'-6".

1. Convert the distance to inches :-  $(47' \times 12") + 6" = 570"$
2. Divide by 10 (magnet pulses) to give the calibration factor:-  $570" / 10 = \underline{57.0}"$
3. Programme the factor '057.0' as described overleaf.

**1.1.4 Radar Sensor**

If an RDS Radar sensor is installed at the correct angle of  $37 \pm 1^\circ$ , the Speed Sensor Factor is **0.0078** m (or **0.312** inches). It is still recommended to do an 'Autocal' since the sensor may not be mounted exactly at  $37^\circ$ .

**1.1.5 RDS 'Satspeed' Interface / NMEA VTG Input**

No calibration is necessary.

## 1.2 Boom configuration

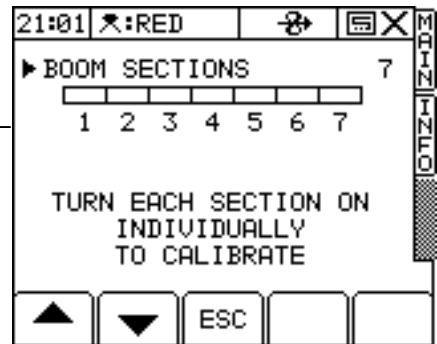
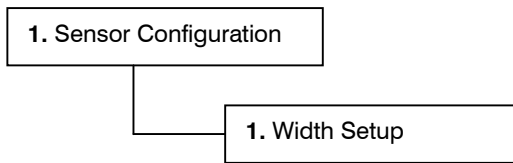

Figure 2

UK572-02.PCX

### 1.2.1 Set number of Boom Sections

Range: 0 - 9 Default: 4

With the screen cursor opposite "BOOM SECTIONS", enter the number of sections from 0 to 9 and press the ENTER button. When a boom section is switched on, the boom section block is filled in.

If boom sections are set to zero, then the whole boom is seen as one unit. The boom section inputs are ignored and the full spraying width is programmed.

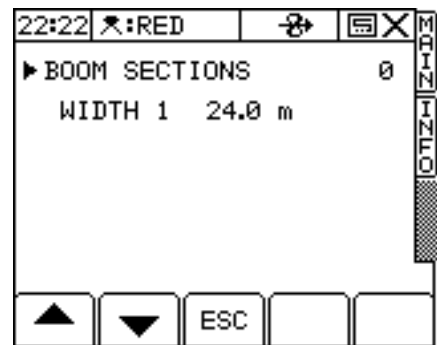

Figure 3

UK572-03.PCX

### 1.2.2 Set No. of Nozzles per section and Nozzle Spacing

Switch on each section in turn and programme the number of nozzles and nozzle spacing for that section.

Figure 4 Setting number of nozzles per section and nozzle spacing

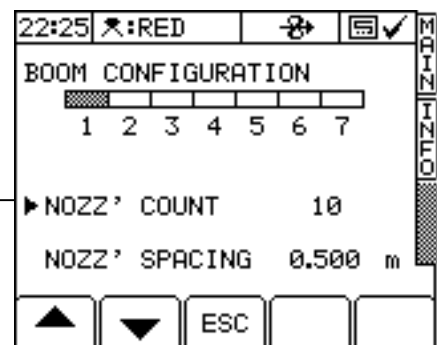
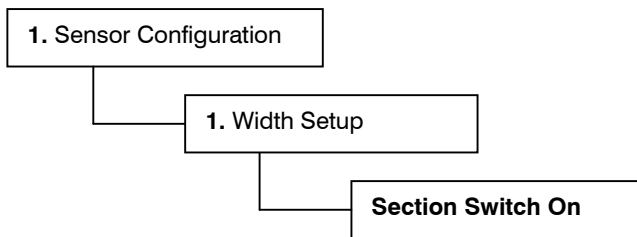

UK572-04.PCX

## 1.3 Selecting the Regulation Mode

- From the SETUP screen, press the  button. (this only appears on the SETUP screen when both sensors are enabled).

Flow-based systems requiring high application rates for liquid fertiliser application, require a large flow sensor to be installed. However, this turbine may not be as accurate at lower application rates required for chemical applications.

Where a large turbine is fitted, it is advantageous for the regulation mode to be set to 'AUTO'. The system will automatically switch to pressure-based regulation when the flow rate drops below the programmed minimum flow rate of the flow sensor.

Figure 5 Switching between flow-based and pressure-based regulation

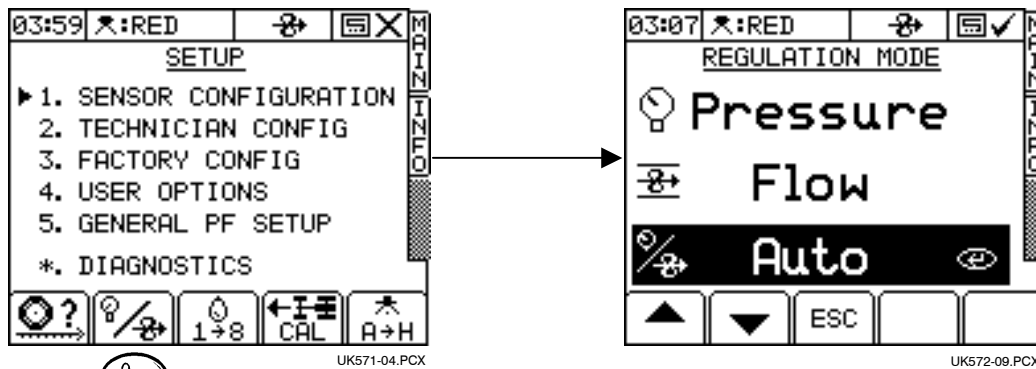

2. Select "Pressure", "Flow" or "Auto" using the up / down arrow keys and press  to confirm.

### 1.4 Flow Sensor Setup

NOTE: Do the Flow sensor setup before doing the liquid calibration.

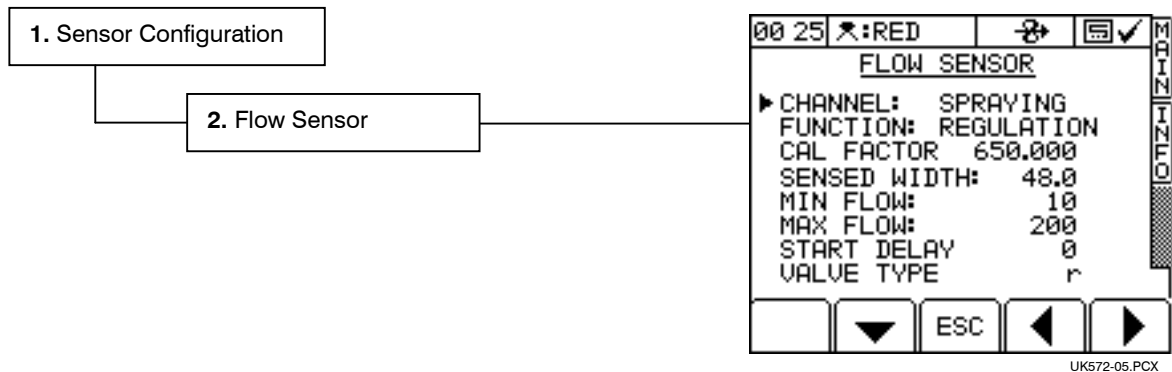

Figure 6

#### 1.4.1 Channel

Select between 'SPRAYING' and 'FILLING' (for calibrating an optional tank fill flow sensor, see section 1.4.8).

#### 1.4.2 Function

"REGULATION" Default setting.

"INFO ONLY" Enables the flow rate display when the instrument is in pressure-based regulation mode.

"NOT USED" For a system where pressure-based only regulation is required. Auto-regulation mode is not available.

#### 1.4.3 Sensed Width

The total width of the boom sections, to which liquid is delivered *via the flow sensor*. This is normally the full boom width but in some installations, for practical reasons, it may be a single boom section.

Default: 48.0 metres

### 1.4.4 Flow sensor Cal factor

The factor (pulses per litre or pulses per gallon) as given below, according to the size of turbine installed.

Turbine size	pulses/litre	pulses/Imperial gallon	pulses/US gallon
1/2"	3700	-	-
3/4"	1786	8119	6760
1"	650.0	2955	2460
1-1/2"	165.0	749.1	624.5
2"	100.0	454.6	378.5

These values will be sufficient until you do a liquid calibration by means of a jug test.

**NOTE:** The Cal Factor will be automatically re-calculated and stored in memory after doing a flow calibration or nozzle calibration routine. It can otherwise be changed manually following "fine tuning" of the nozzle rate. Default setting: 650 pulses/litre for a 1" turbine

### 1.4.5 Minimum flow and Maximum flow

Set the values according to the size of turbine fitted.

Turbine size	Min. flow (l / min)	Max. flow (l / min)
1/2"	3	30
3/4"	3	30
1"	10	100
1-1/4"	10	100
1-1/2"	35	350
2"	72	1100

These values set the threshold for the "FLOW LOW" and "FLOW HIGH" alarms during operation. Minimum and maximum flow can also be set from the "ALARMS SETUP" screen. Set the maximum and minimum flow for the sensor in use.

Default: Min. flow = 10 l/min      Max. flow = 200 l/min

### 1.4.6 Start Delay

When the whole boom or any boom section is switched on, there may be a rush of air or liquid as the boom line fills up which is not true flow out to ground. Flow accumulation will be ignored for this delay time (programmable from 0 - 20 seconds) after the boom is switched on. The flow should stop immediately the boom is switched off.

Default = 0 sec

### 1.4.7 Valve Type

If each boom section valve when closed, simply shuts off the flow (e.g. solenoid valves), set to "n" for a non-recirculating system.

If each boom section valve when closed, diverts the flow back to tank (e.g. ARAG, Spray Systems valves), set to "r" for a re-circulating 'balanced return' system.

Default: "r"

### 1.4.8 Calibrating a Tank Filling Sensor

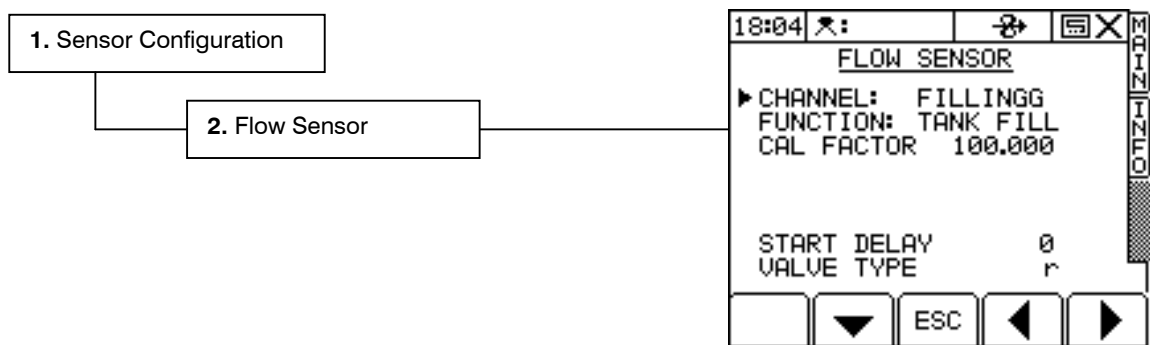

Figure 7a

UK57207A.PCX

With the cursor on 'CHANNEL', select ' FILLING'.

1. Initially set the calibration factor according to the size of turbine installed (1.4.4).

*Default: 650 pulses/litre (for a 1" turbine).*

2. Select the "INFO" screen and press  to access the TANK FILL screen.

3. Set the "NOW" volume to zero.

4. Fill the empty tank with the known volume (e.g. 2000 litres) of water via the inflow sensor and note the "NOW" volume displayed.

The correct Cal. factor = Initial Factor x  $\frac{\text{"NOW" volume}}{\text{Actual volume}}$

e.g. Initial Cal. Factor = 100 and the "NOW" volume reads 1750 litres after filling 2000 litres;

New Cal. Factor =  $100 \times (1750/2000) = 87.5$

5. Go back to the "FLOW SENSOR" screen, key-in the new Cal. Factor and press  .

### 1.5 Pressure sensor setup

NOTE: Do the Pressure sensor setup before doing the liquid calibration.

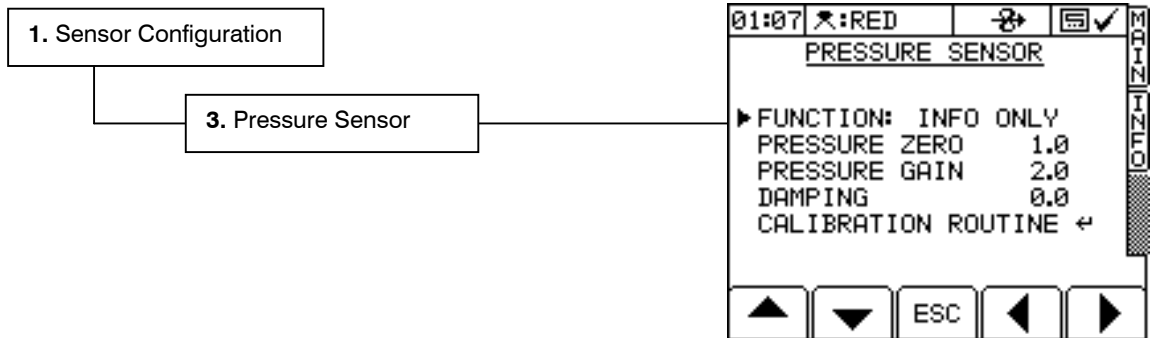

Figure 7b

UK572-06.PCX

#### 1.5.1 Function

"REGULATION" Default setting.





"INFO ONLY" Enables the pressure display when the instrument is in flow-based regulation mode.

"NOT USED" For a system where flow-based only regulation is required. Auto-regulation mode is not available.

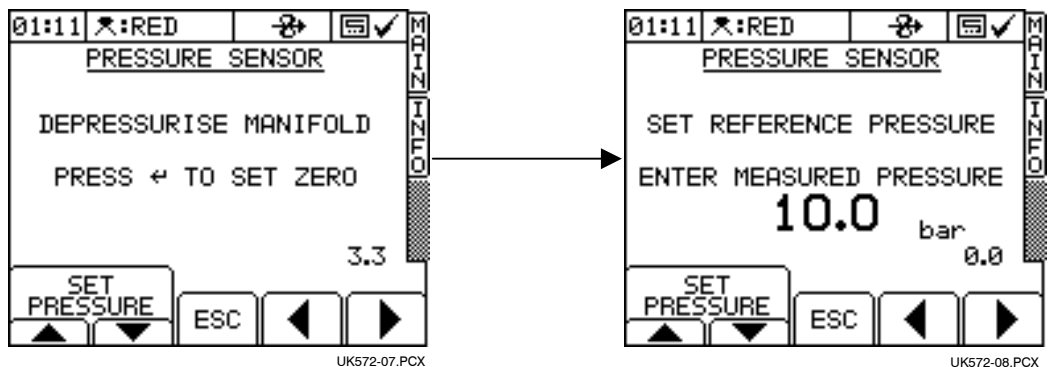
#### 1.5.2 Calibrate Pressure Sensor

Figure 8a / 8b Calibrating the Pressure Sensor



1. Select "CALIBRATION ROUTINE" (fig. 7) and press  .
2. Depressurize the manifold and press  to set "PRESSURE ZERO" (fig. 8a).
3. Start the sprayer and set the reference pressure (the typical working pressure) using the  keys (fig. 8b).
4. Key-in the pressure indicated on the sprayer pressure gauge and press  .

The "PRESSURE GAIN" is then set and is displayed on the "PRESSURE SENSOR" screen (fig. 7). The pressure sensor is now calibrated ready for nozzle calibration.

#### 1.5.3 Damping

The damping factor enables fluctuations in the pressure readings to be smoothed out. By default the damping factor is zero.

## 1.6 Configuring the Control Valve

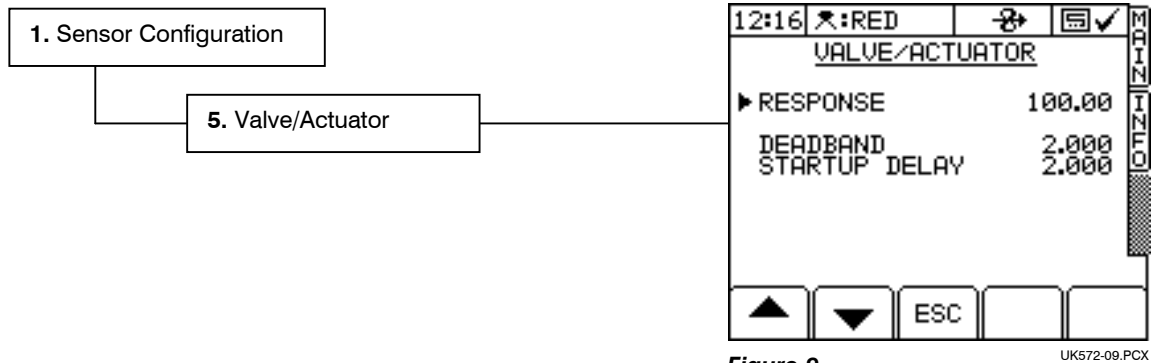



Figure 9

UK572-09.PCX

### 1.6.1 Response

The Response function sets the frequency at which the system adjusts the control valve when reacting to a change in forward speed.

Determining the correct setting is a method of trial and error as follows,

1. With the sprayer stationary, from the SETUP page, press  and ENTER to begin a simulated speed.
2. Run the sprayer in manual ('MAN') control mode and adjust the pressure down to a minimum.
3. Switch to automatic ('AUTO') mode and observe the response.

If the application rate quickly rises and settles at the target rate then the response setting is correct.

A lower setting results in a slower response, and increases the time taken for the application rate to match the target rate. A higher setting results in a faster response. If the application rate is unstable and varies about the target rate, then the response setting may be too high.

Default: 100    Range: 0 - 9999

### 1.6.2 Deadband

The Deadband function sets the range over which the flow rate will vary about the target rate before the control valve will respond. A lower value will make the control respond to a smaller variation in flow and vice versa. If the value is too low the system may be unstable about the target rate.

Default: 2.0    Range: 0 - 99.9

### 1.6.3 Startup Delay

If a spray boom is empty of liquid, the flow into it is rapid until it pressurises. The flow rate then reduces to the correct flow rate. Consequently the system takes some time to stabilise at the target rate. The instrument must be stopped from reacting to the initial flow surge.

Set the delay time to equal the time it takes for the sprayer system to reach normal working pressure. When the whole boom or individual section is switched on, the control valve will not operate for this time period.

Default: 2.0 seconds    Range: 0 - 99.5 seconds

**NOTE:** The power supply to the control valve is switched off when switching off the boom. Therefore, when the sprayer is switched on at the beginning of the next bout, the control valve will be in the correct position enabling a faster return to the target rate.

### 1.7 Alarms

There are a number of alarms, most being programmable by the operator. Note that setting alarm limits to zero will disable that alarm function.

<b>Application Rate</b>	<b>'UNDER APPLICATION'</b> <b>'OVER APPLICATION'</b>	This alarm is based on % variance from the target rate. It therefore alerts the operator to speed up or slow down until the alarm condition is cancelled.  The limits can be set by the operator on the ' <b>Alarms Setup</b> ' screen in the SETUP menu. The default limits are $\pm 20\%$ of the target rate.
The following alarms can also be configured if so desired, but would normally be overridden by the application rate alarm if set (except for RPM alarm). The limits must be set in respect of flow sensor capacity / spray performance.		
<b>Forward Speed</b>	<b>'FORWARD SPEED LOW'</b> <b>'FORWARD SPEED HIGH'</b>	The limits can be set by the operator on the ' <b>Alarms Setup</b> ' screen in the SETUP menu.
<b>Flow Rate</b> <i>(Alarm effective in flow-based regulation mode only)</i>	<b>'FLOW LOW 1'</b> <b>'FLOW HIGH 1'</b>	The limits can be set by the operator on the ' <b>Alarms Setup</b> ' screen in the SETUP menu.  They must be set correctly to suit the size of flow sensor fitted, and to ensure that the system switches properly between flow-based regulation and pressure-based regulation, if the instrument is operating in the 'AUTO' regulation mode.  NOTE: These limits are also displayed on the ' <b>Flow Sensor</b> ' setup screen in the SETUP menu.
<b>Pressure</b> <i>(Alarm effective in pressure-based regulation mode only)</i>	<b>'PRESSURE LOW'</b> <b>'PRESSURE HIGH'</b>	The limits are those calculated and displayed on the nozzle wizard screen. They are not programmable by the operator.
<b>RPM</b>	<b>'RPM LOW'</b> <b>'RPM HIGH'</b>	The limits can be set by the operator on the ' <b>RPM Setup</b> ' screen in the SETUP menu.

'FLOW HIGH 1' may be caused by the control valve being unable to dump sufficient flow back to the sprayer tank as a result of:- speed too slow or stationary, too small or too few nozzles in use - sections off or blocked nozzles, pump capacity too large or control valve too small.

'FLOW LOW 1' may be caused by:- forward speed too high, insufficient pump capacity, low pump speed, low or empty tank, blocked filters or incorrect jets.

#### 1.7.1 Setting the Alarm thresholds

1. Press  to select the "SETUP" menu.
2. Select the "ALARMS SETUP" screen (fig.10).

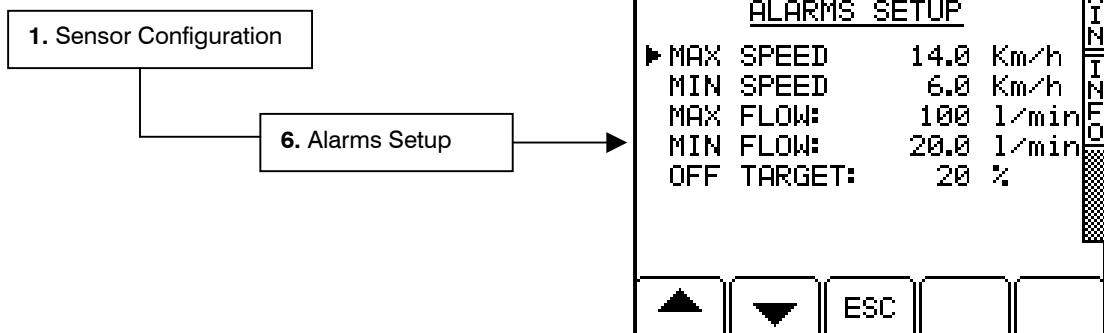

Figure 10

UK571-10.PCX

### 1.7.2 MAX. SPEED and MIN. SPEED

These values set the thresholds for the forward speed alarms. They are automatically set according to the Target Speed in the "Nozzle Wizard", however, you can manually key-in another value via the alpha-numeric keypad.

When another nozzle type is selected in the "Nozzle Wizard", any manually programmed thresholds will be overwritten by the "Nozzle Wizard".

Default = 0 (Alarms Off)

### 1.7.3 MAX. FLOW and MIN. FLOW (Flow-based regulation only)

These values set the thresholds for the "FLOW HIGH" and "FLOW LOW" alarms during operation. Minimum and maximum flow can also be set from the "FLOW SENSOR" screen. Set the values according to the size of turbine fitted (ref. section 1.4.4).

Default: Min. flow = 10 l/min      Max. flow = 200 l/min

### 1.7.4 OFF TARGET

This sets the threshold at which the instrument will alarm "UNDER APPLICATION" or "OVER APPLICATION" when spraying in automatic control mode. It is set as a percentage either side of the current target rate.

NOTE: This can also be set from the "CONTROL OPTIONS" page.

Default = ± 20%

## 1.8 Calibrating an RPM Sensor

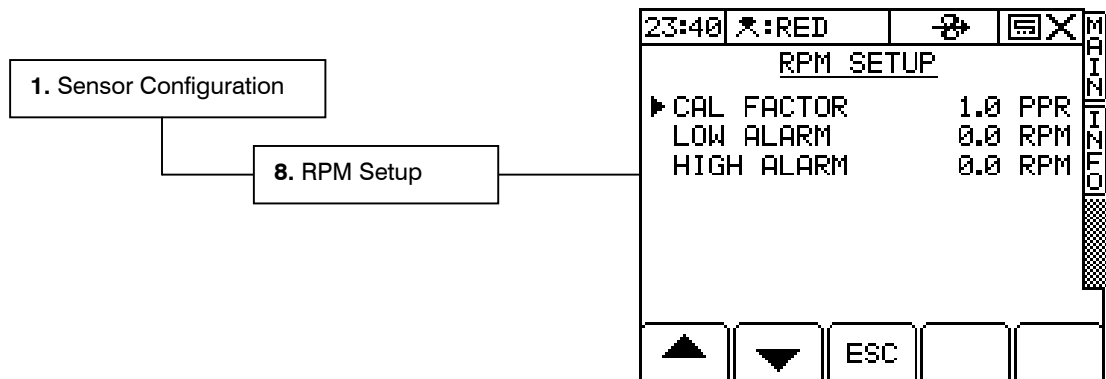



Figure 11

UK572-11.PCX

The following calibration procedure applies regardless of the speed output being sensed e.g. Engine RPM, PTO Speed, Shaft Speed, Fan Speed etc, depending on the particular installation.

In all cases, run the sensed component at a known speed. If necessary measure this speed using a hand-held tachometer. Note the speed displayed on the "INFO" screen.

The correct Cal. factor = Initial Factor x  $\frac{\text{Displayed Speed}}{\text{Actual Speed}}$

Go back to the "RPM SETUP" screen, key-in the new Cal. Factor and press .

Default: 1 pulse per rev (PPR)

### 1.8.1 LOW / HIGH RPM ALARM

From the RPM SETUP screen, you can also set a minimum and maximum RPM at which an alarm is triggered. Set as necessary.

Default = 0 (Alarms Off)

## 2. Liquid calibration

It is important to ensure that the flow / pressure sensors have been properly configured before doing a liquid calibration.

**NOTE:** Liquid calibration is always done with water. When spraying denser liquids such as liquid fertilizers, after doing the jug test you should programme the correct density for that product, from the "PRODUCT SELECTION" screen (section 2.4.1- Operation).

### 2.1 Initial Calibration - using the "Nozzle Calibration Routine"

The following procedure applies for both pressure-based and flow-based regulation.

1. First set the desired target speed and target rate (ref. section 2.1 - Operation).
2. Then select the most suitable nozzles using the 'Nozzle Wizard" (ref. section 2.2 - Operation).

**NOTE:** If calibrating twin spray lines,. You must perform the following nozzle calibration routine three times- for Line 'A', then for Line 'B', and finally for Lines 'A' + 'B'.



3. From the 'Nozzle wizard' screen, first select the appropriate spray line, then press  . The current calibration speed is displayed.
4. Change the calibration speed if desired, from that displayed and press  to accept. The adjusted speed is used for calibration only and will not change the target speed set. The "CAL TEST" screen is then displayed. It flashes "CAL" to indicate that speed is being simulated, and gives the message "TURN ON NOW" (fig. 13).
5. Switch the sprayer on. It is better the calibration test is carried out with the full boom spraying, as this reproduces the field conditions and any pressure drops across the system.
6. When a boom section is switched on, the "CAL TEST" screen appears. All parameters will display '- - - -'. Until the control system has stabilized. The screen then displays the calculated application rate and individual nozzle flow rate. If a pressure sensor is fitted, the pressure is also displayed (fig. 14).

Figure 12 Nozzle calibration routine



UK57118a.PCX

Figure 13



UK57118b.PCX

Figure 14

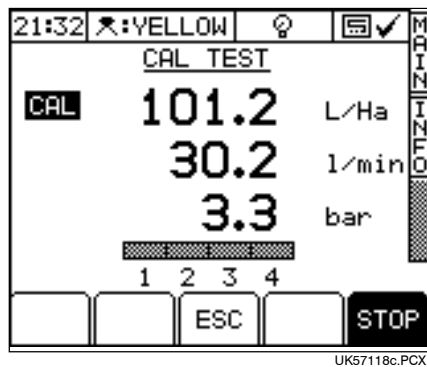

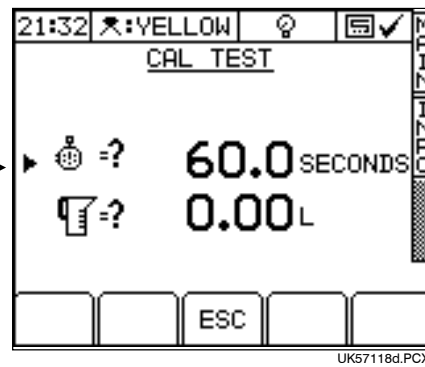

UK57118c.PCX

Figure 15



UK57118d.PCX

When a steady state is achieved, carry out the jug test by collecting a quantity of water from a single nozzle, and record the collection time

7. Press the 'STOP' key to end the metering period.
8. Enter the actual time the jug was under the nozzle (default = 60 sec) and press  .
9. Enter the test volume (or averaged test volume – see note 1) and press  .

The instrument then calculates and displays the new calibration factors (fig. 16). If you can have both a flow sensor and pressure sensor enabled, you will see both:-

- NOZZLE FLOW RATE in litres/min/nozzle ("REF' FLOW" on the nozzle data page) for pressure-based regulation.
- FLOW SENSOR CALIBRATION FACTOR in pulses per litre for flow-based regulation.

**Figure 16** Flow Calibration Factors



**NOTE 1** It is advisable to repeat the jug test for several nozzles across the boom and enter the average of the individual test volumes.

10. Press  to accept the settings, (or first enter revised figures e.g. the averaged flow rate over a number of jug tests).

If you don't want to accept the calculated result, press ESC to return to the "Nozzle Wizard" screen.

**NOTE 2** Performing the jug test changes the previous nozzle flow rate ("REF FLOW") figure stored in the "Nozzle Wizard", and will also correct the calibration factor for the flow turbine.

*The jug test is not the most accurate method of calibration particularly for the flow turbine on flow-regulated systems, as the test volume is relatively small. It is therefore recommended to subsequently perform a full-tank calibration, spraying a full tank out in the field.*

11. If operating with dual spray lines, perform the calibration test routine separately for line 'A' nozzles, then line 'B' nozzles, and finally both sets of nozzles.

## 2.2 Full-Tank Calibration

The calibration figure should be subsequently "fine-tuned" after spraying out a full tank in the field. Be certain of the volume sprayed out since the sprayer sight gauge may not be accurate enough for calibration purposes. The liquid calibration should be checked and adjusted regularly over the season to compensate for factors including nozzle wear.



1. From the SETUP page press  to select the "PRODUCT SELECTION" page.
2. If you are spraying clean water or chemicals, check that the product (default name = "Spray A") has density set to 1.00. If spraying liquid fertiliser, check the product and density is selected and programmed.
3. Select the "INFO" screen and reset the "PART TOTAL" to zero.
4. Spray out the whole tank then select the "INFO" screen and note the "PART TOTAL" clocked.
5. Compare this with the known volume sprayed out. If there is a difference between the two figures, then correct the error via the CAL NUDGE screen as follows:
6. Go back to the "PRODUCT SELECTION" page, select "PRODUCT CALIBRATION" and press  (fig. 17).
7. Select "CAL NUDGE" and press  .

Figure 17 Nudging the cal factors

Figure 18

Figure 19







UK57120.PCX

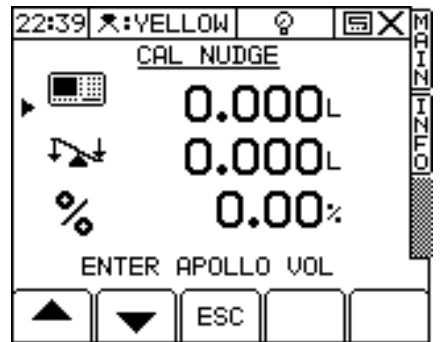

UK57121.PCX



UK57122.PCX

8. Enter the instrument total (  ) and press  , then the known volume sprayed out (  ), and press  . Finally, press  again to confirm the nudge. The calibration factors are then adjusted accordingly.

### 3. Technician Configuration Menu

The operator is unlikely to need access in normal use. Access to this menu can be restricted by changing the PIN number from within the menu.

Enter the factory default PIN number 1234 to access the menu.

#### 3.1 Display Options

Figure 20 "Display Options" page

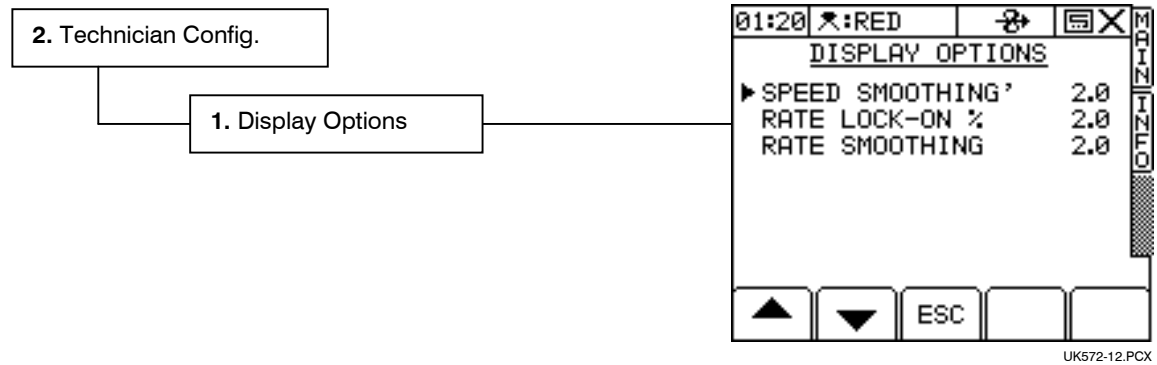

##### 3.1.1 Speed Smoothing Factor

The Forward Speed display is electronically damped. If the readouts are constantly changing by small increments, you can increase the damping time to give a steadier readout.

Adjustable from 0 to 19 seconds. Default = 2 seconds

##### 3.1.2 Rate Lock-On

"RATE LOCK-ON" sets the % by which the application rate fluctuates either side of a nominal application rate before the instrument display changes.

For example, if your actual application rate fluctuates in normal operation from 97 to 103 l/ha for a target application rate of 100 l/ha, you may decide that it is acceptable for the instrument to display a steady readout of 100 l/ha between those limits i.e.  $\pm 3\%$ . In this case the rate lock-on figure should be set to 3.0.

Adjustable from 0 to 50% Default = 2%

##### 3.1.3 Rate Smoothing

The Application rate display is electronically damped. If the readouts are constantly changing by small increments, you can increase the damping time to give a steadier readout.

Adjustable from 0 to 19 seconds. Default = 2 seconds

#### 3.2 Control Options

Figure 21 "Control Options" page

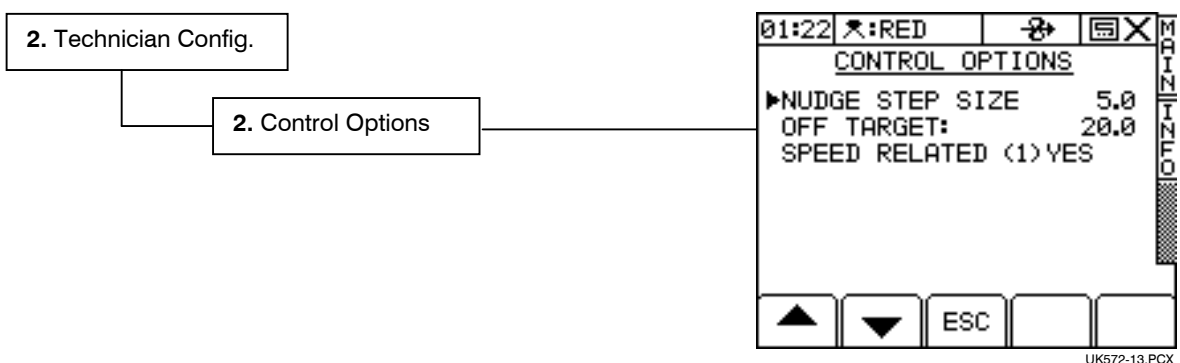

### 3.2.1 Nudge Step Size

The Nudge Step Size sets the % increase / decrease made when you adjust from the target rate in AUTO mode. Adjustable from 0 to 50%.

Default = 5%

### 3.2.2 Off Target Alarm

This sets the threshold at which the instrument will alarm "UNDER APPLICATION" or "OVER APPLICATION" when spraying in automatic control mode. It is set as a percentage either side of the current target rate.

NOTE: This can also be set from the "ALARMS SETUP" page.

Adjustable from 0 to 50%.

Default = 20%

### 3.2.3 SPEED RELATED: Options

Default = "YES" - This enables the flow rate to be automatically adjusted according to the forward speed, to match the target application rate (l/ha) in AUTO mode.

"NO" - [Setting not used for sprayers]

## 3.3 Boom Cutouts / Inputs

Figure 22 "Boom/Cutouts Inputs" page

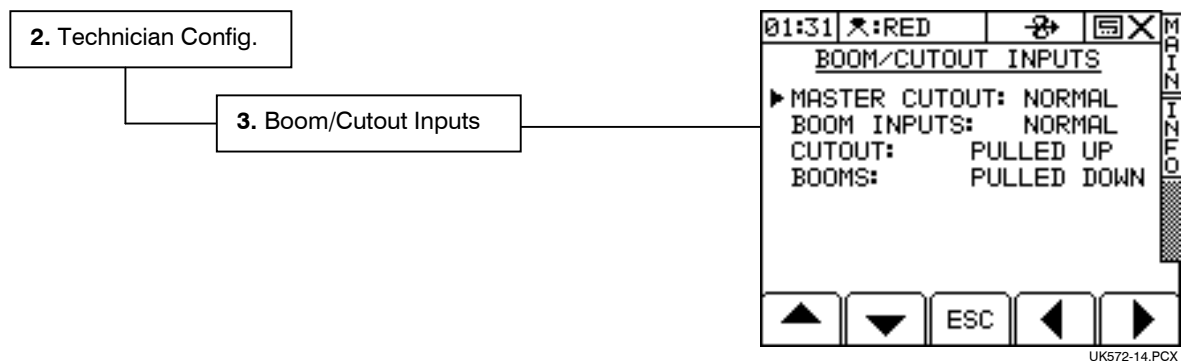

#### Master Cutout

**NORMAL:** The sprayer is ON when the cutout input is NOT recognised.

**INVERTED:** The sprayer is ON when the cutout input is recognised.

#### Boom Inputs

**NORMAL:** The boom section is ON when the boom section input is recognised.

**INVERTED:** The boom section is OFF when the boom section input is recognised.

#### Cutout

**PULLED UP;** Master cutout input is recognised when it closes to 0V.

**PULLED DOWN:** Master cutout input is recognised when it closes to +V.

#### Booms

**PULLED UP;** Boom section input is recognised when it closes to 0V.

**PULLED DOWN:** Boom section input is recognised when it closes to +V.

Default settings shown in bold. Change as required using the arrow keys.

### 3.4 **Print Calibration Data**

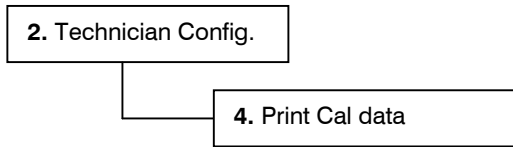

It is always a good idea to keep a record of calibration data either in the back of the manual, or as a printout. Connect the printer to the upper serial port. Ensure first that the port has been configured for a printer (section 4.5.1).

Selecting the "PRINT CAL DATA" menu function immediately sends the data to the serial port. The message "Printing Data" is displayed while data transfer is occurring.

If the bar on the screen stops filling up part way, the instrument cannot communicate with the printer. Check the connections.

### 3.5 **Ports Setup**

Please refer to the "Data Logging and Transfer" manual – ref. S/DC/500-10-573

### 3.6 **Change PIN for Technician Menu**

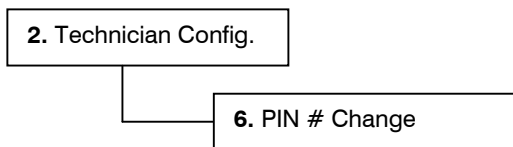

You can re-programme your own PIN for this menu. Just follow the screen instructions.

If you forget your personalised PIN, you will need to contact RDS for instructions.

## 4. Factory Configuration Menu

The operator is unlikely to need access in normal use. Access to this menu can be restricted by changing the PIN number from within the menu.

Enter the default PIN number 1234 to access the menu.

### 4.1 Machine Options

Figure 23

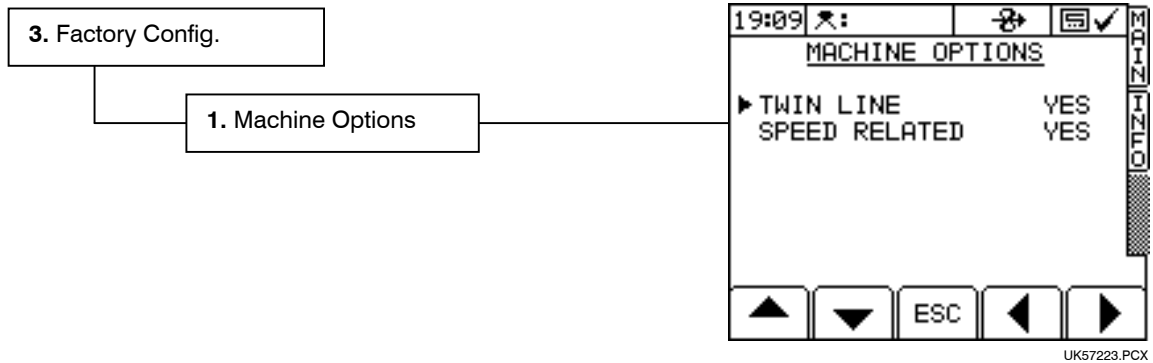

#### “TWIN LINE”

Default = "NO". Select "YES" to enable dual spray line control.

#### “SPEED RELATED”

Default = "YES" - This enables the flow rate to be automatically adjusted according to the forward speed, to match the target application rate (l/ha) in AUTO mode.

"NO" - [Setting not used for sprayers]

### 4.2 Total Software Reset

A "FACTOR RESET" should be considered in two instances. Firstly, if the instrument is transferred to a different sprayer, it may be easier to re-calibrate the instrument from the factory default settings in a systematic way. Secondly, if you are encountering problems with the instrument during operation but cannot successfully resolve them, a total software reset may help in the troubleshooting procedure.

Follow the screen prompts to reset the instrument to the factory default settings.

**NOTE:** All customised factors and other data will be lost. It is recommended you keep a record of the existing calibration data.

### 4.3 Backing Up and Restoring Calibration Data

For extra security, calibration data can be manually saved to a separate memory area called "STORE A". This data will NOT be overwritten each time the instrument is switched off, but it WILL be cleared after a Total Software Reset ("RESET FACTORS").

If for example, any calibration data is unwittingly changed without keeping a record of previous settings or data is corrupted, you can restore the calibration data from "STORE A" at any time.

### 4.4 Change PIN for Factory Configuration Menu

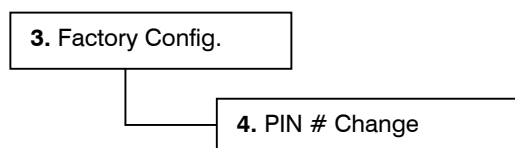

You can re-programme your own PIN for this menu. Just follow the screen instructions. If you forget your personalised PIN, you will need to contact RDS for instructions.

## 5. User Options

### 5.1 Set Time and Date

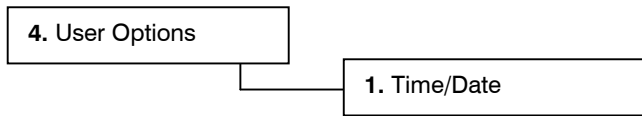

If you need to change the time or date setting, position the cursor against the relevant line, key-in the new value and press .

### 5.2 Adjust Screen Contrast and Brightness

Figure 19

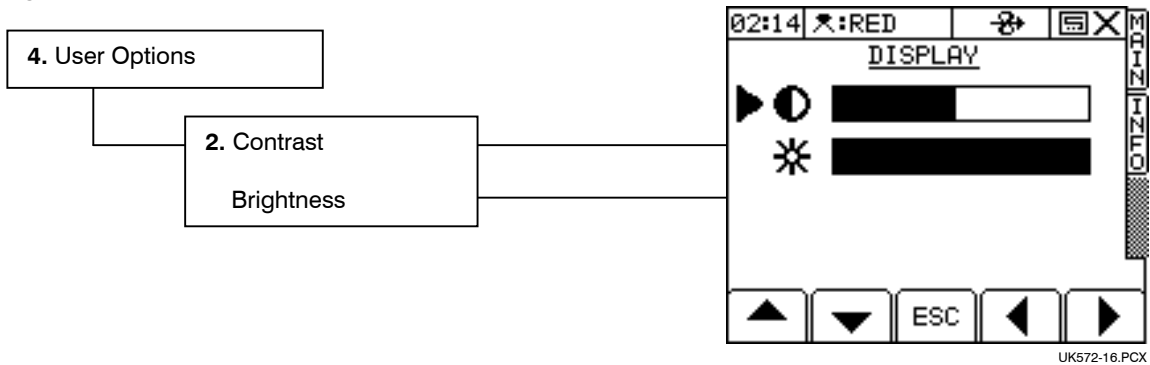

The screen may go darker at very high or very low temperatures. For example, on a very cold morning it may take a short period of time for the display to gain normal contrast as the instrument warms up. This is a normal characteristic of this type of display and does not mean the display is faulty.

If by accident the contrast setting is adjusted so that the screen graphics can no longer be viewed (i.e. completely light or dark), don't panic! - you can navigate directly to the "DISPLAY" screen by pressing and holding the  key for at least 10 seconds. The instrument will beep at 2-second intervals as long as the key is depressed. You can then adjust the display using the arrow keys.

### 5.3 Set Units

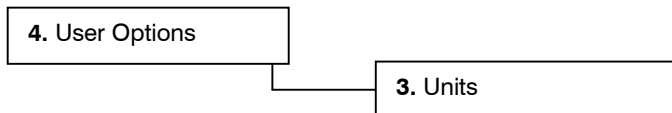

Information can be displayed in Metric or Imperial units by selecting the desired option via the SETUP menu.

Function	Units	
	Metric	UK Imperial
Forward Speed	km/hr	miles/h
Application rate	litres/ha	gallons/acre
	kg/ha	lbs/acre
	tonnes/ha	tons/acre
	m <sup>3</sup> /ha	kgals/acre
	ml/m <sup>2</sup>	floz/ft <sup>2</sup>
Flow rate	litres/min	gallons/min
Part/Total Area	hectares	acres
Tank volume/ Part/Total volume applied	litres	gallons
Spray pressure	bar	lbs/in <sup>2</sup>

## 5.4 Select Language

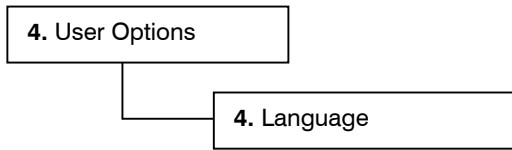

Select the language using the up / down arrow keys and press .

## 5.5 Select Control Software

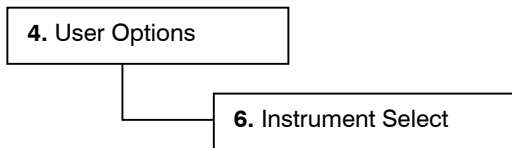

There are two lines displayed. If the head unit does not have a secondary software module fitted, both lines will be the same and switching between them has no effect.

If a software module is fitted, then simply select between the two software options displayed and press . The instrument will take several seconds to load the control software and then automatically re-start.

## 6. General PF Setup

Please refer to the "Data Logging and Transfer" manual (ref. RDS Pt. No. S/DC/500-10-573).

## 7. The SETUP menu

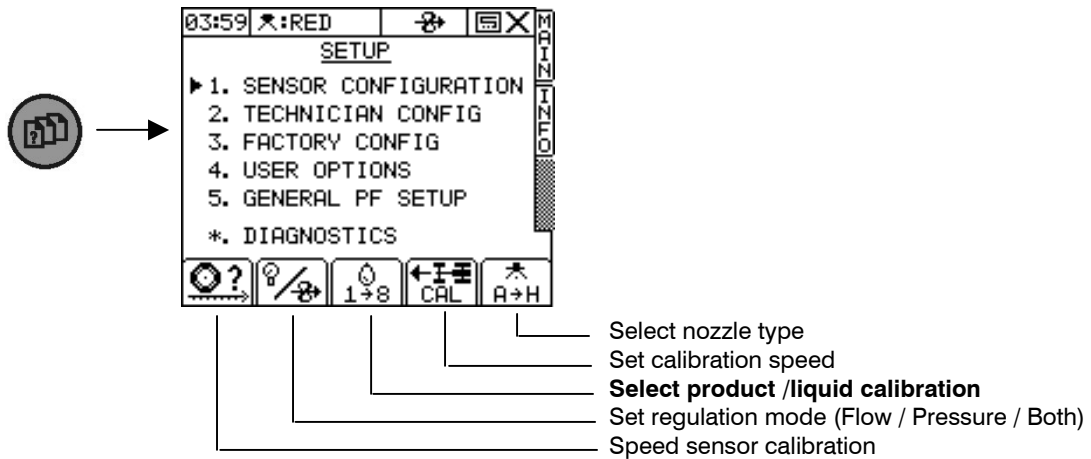

1 <sup>st</sup> Level	2 <sup>nd</sup> Level	Parameter	Setting [default]	Your settings
1. Sensor Config. —	1. Width Setup	No. of Boom sections	1 to 9	<input type="text"/>
		Nozzle count	10	<input type="text"/>
		Nozzle spacing	0.5 m	<input type="text"/>
	2. Flow Sensor	Tank	[No function]	<input type="text"/>
		Function	REGULATION	<input type="text"/>
		Cal Factor	650.0	<input type="text"/>
		Sensed Width	48.0	<input type="text"/>
		Min. Flow	10	<input type="text"/>
		Max. Flow	200	<input type="text"/>
		Start Delay	0	<input type="text"/>
	3. Pressure Sensor	Tank	[No function]	<input type="text"/>
		Function	NOT USED	<input type="text"/>
		Pressure Zero	1.0	<input type="text"/>
		Pressure Gain	2.0	<input type="text"/>
	4. Load Sensor	Damping	0	<input type="text"/>
		<b>Calibration routine</b>		
		Tank	[No function]	<input type="text"/>
		Function	NOT USED	<input type="text"/>
		Load Zero	2.50	<input type="text"/>
		Load Gain	45.0	<input type="text"/>
Calibration routine				
5. Valve/Actuator	Angle Sensor	Slope L/R	<input type="text"/>	
	Temperature Sensor	Slope F/B	<input type="text"/>	
	CAN Diagnostics			
	Response	Response	100.0	<input type="text"/>
		Deadband	2.0	<input type="text"/>
		Startup Delay	2.0	<input type="text"/>

1 <sup>st</sup> Level	2 <sup>nd</sup> Level	Parameter	Setting [default]	Your settings	
2. Technician Config.	6. Alarms Setup	Max. Speed	0 km/hr	<input type="text"/>	
		Min. Speed	0 km/hr	<input type="text"/>	
		Max Flow	200 l/min	<input type="text"/>	
		Min Flow	10 l/min	<input type="text"/>	
		Off Target	20%	<input type="text"/>	
	7. Nozzle Setup	Ref. Operation manual	Section 2.3		
		8. RPM Setup	Cal Factor	1.0	<input type="text"/>
	2. Technician Config.	1. Display Options	Low Alarm	0	<input type="text"/>
			High Alarm	0	<input type="text"/>
			Speed Smoothing	2.0	
2. Control Options		Rate Lock-on %	2.0		
		Rate Smoothing	2.0		
		Nudge Step Size	5.0 (%)	<input type="text"/>	
3. Boom/Cutout Inputs		Off Target	20.0 (%)	<input type="text"/>	
		Speed Related?	YES	<input type="text"/>	
		Master Cutout:	Normal	<input type="text"/>	
3. Factory Config.		3. Boom/Cutout Inputs	Boom Inputs:	Normal	<input type="text"/>
	Cutout:		Pulled Up	<input type="text"/>	
	Booms:		Pulled Down	<input type="text"/>	
	4. Print Cal Data				
3. Factory Config.	5. Ports Setup	Top Port	(ref. General P.F. Setup menu)		
		Bottom Port			
	6. PIN Change	Tech. Menu Pin #	Default = 1234	<input type="text"/>	
		1. Machine Options	TWIN LINE Speed related?	YES / [NO] [YES] / NO	<input type="text"/>
4. User Options	2. Factors Reset				
	3. Factors Store	Save to Store A			
		Restore from A			
	4. PIN Change	Tech. Menu Pin #	Default = 1234	<input type="text"/>	
	4. User Options	1. Time/Date			
		2. Contrast/Brightness			
3. Units					
4. Language					
5. Helpline					
6. Instrument Select					

1 <sup>st</sup> Level	2 <sup>nd</sup> Level	Parameter	Setting [default]	Your settings
5. Gen. P.F. Setup	1. Logging Interval	Log by Time	2s	<input type="text"/>
		Log by Distance	6m	<input type="text"/>
	2. Tag Names	1	Black Grass	<input type="text"/>
		2	Wild Oats	<input type="text"/>
		3	Cleavers	<input type="text"/>
		4	Thistles	<input type="text"/>
		5	Spare Tag 1	<input type="text"/>
		6	Spare Tag 2	<input type="text"/>
		7	Spare Tag 3	<input type="text"/>
		8	Spare Tag 4	<input type="text"/>
	3. Func. Names/Values	F1	Func 1	<input type="text"/>
		F2	Func 2	<input type="text"/>
		F3	Func 3	<input type="text"/>
		F4	Func 4	<input type="text"/>
		F5	Func 5	<input type="text"/>
		F6	Func 6	<input type="text"/>
		F7	Func 7	<input type="text"/>
		F8	Func 8	<input type="text"/>
		F9	Func 9	<input type="text"/>
		F10	Func 10	<input type="text"/>
		F11	Func 11	<input type="text"/>
		F12	Func 12	<input type="text"/>
	4. GPS Antenna Offsets	Left/Right	0m	<input type="text"/>
		Front/Rear	0m	<input type="text"/>
	5. GPS Baudrate	4800 / 9600 / 19200		
	6. Ports Setup	Top Port	Not Used GPS Only GPS + Amatron Plus GPS + Bogballe GPS + LH5000 v4 GPS + Kverneland	
		Bottom Port	Not Used RDS Printer ICP200 PC Download RDS PF Module Fieldstar type 1 Agrocom ACT YARA N-Sensor JD Greenstar Raven 4800 Raven 9600	

Issue 1: 12/2/08

Original Issue

Issue 2: 17/6/09

Ref. section 1.6.1 add procedure, "Pause Time" deleted.