



Delta 34i Sprayer Controller Operation

RDS Part No.:	S/DC/500-10-571
Document Issue:	1.0 : 12/2/08
Software Issue:	PS521-001 rev 09

Electromagnetic Compatibility (EMC)



This product complies with Council Directive 2004/108/EEC when installed and used in accordance with the relevant instructions.

IMPORTANT, READ THIS BEFORE USING THE PS8000i

The *PS8000i* installation is a part of the Precision Farming System ("the System"). It is very important that you follow the described calibration procedures before operating the *PS8000i* instrument. Calibration and operation of the *PS8000i* must be in accordance with these instructions. Use of the System is subject to the following disclaimer;

1. So far as is legally permissible RDS Technology ("RDS"), or its distributors, shall not be liable, whatever the cause, for any increased costs, loss of profits, business, contracts, income, or anticipate savings or for any special, indirect or inconsequential damage whatsoever (death or personal injury excluded).
2. The capabilities and functions of the Precision Farming System ("the System") are limited as set out in the specification of the System, details of which are contained in the Help files and product literature and which must be read before using the System.
3. Without prejudice to the generality of the above it is hereby acknowledged that the System is not designed nor intended to a) originate variable treatment plans or b) achieve or avoid any application rate outside application parameters, which in both cases shall be the responsibility of the operator.
4. The standard terms and conditions of RDS (except clause 7), a copy of which is available on request, apply to the supply and operation of this System.

Service and Technical Support

PLEASE CONTACT YOUR NEAREST RDS DISTRIBUTOR if unknown then contact RDS Technology Ltd for further information,

Tel : +44 (0) 1453 733300

Fax : +44 (0) 1453 733311

e-mail : info@rdstec.com

web : www.rdstec.com

Our policy is one of continuous improvement and the information in this document is subject to change without notice. Check that the software reference matches that displayed by the instrument.

© Copyright RDS Technology Ltd 2008

\\UK571100.DOC

1.	OVERVIEW	5
1.1	<i>The RDS Precision Farming System</i>	5
1.2	<i>Installation and Inter-operability with other systems</i>	5
1.3	<i>Control Software</i>	5
1.4	<i>Control System</i>	5
1.5	Sprayer Control Modes	7
1.5.1	Dual Spray Line Control	7
1.5.2	Automatic Control Mode	7
1.5.3	Manual Control Mode	7
1.5.4	VRT (Variable-rate treatment) Control Mode	7
1.6	The Head Unit Keypad	8
1.6.1	Menu keys	8
1.6.2	Startup	8
1.6.3	Data Entry	8
1.7	The MAIN screen page	9
1.7.1	Target Rate Indicator	9
1.7.2	Spray performance Indicator	9
1.7.3	MAIN Screen Display Options	10
1.8	The INFO screen page	11
1.9	The LOG screen page	11
1.10	The SETUP screen page	12
1.11	Units	12
2.	OPERATION	13
2.1	Setting the target rate and target speed	13
2.2	Selecting the Nozzle size	13
2.2.1	Single Spray Line	13
2.2.2	Dual Spray Line	14
2.2.3	Editing the preset Nozzle type	15
2.3	Selecting the Regulation Mode	15
2.4	Product presets	16
2.4.1	Selecting a product	16
2.4.2	Editing a product name	16
2.4.3	Programming a product density	16
2.5	Automatic Rate Control	17
2.5.1	Setting the Target Rate	17
2.5.2	Overriding the Target Rate	17
2.6	Manual Rate Control	17
2.7	Dual Spray Line Control in AUTOMATIC or MANUAL mode	18
2.8	Tank Contents	19
2.8.1	Tank fill (manual)	19
2.8.2	Tank filling (Automatic)	19
2.9	Part / Total Accumulation and RPM display	20
2.9.1	Reset Totals	20
2.10	Alarms	20
2.10.1	Setting the Alarm thresholds	21

3.	LIQUID CALIBRATION	22
3.1	Initial Calibration - using the "Nozzle Calibration Routine"	22
3.2	Full-Tank Calibration	24

1. Overview

1.1 The RDS Precision Farming System

The RDS *PS8000i* head unit is a fully DGPS compatible, multi-function cab computer for a wide range of applications and is the central component of RDS Precision Farming hardware (figure 1).

Figure 1 The Pro-Series is the central component of RDS Precision Farming hardware

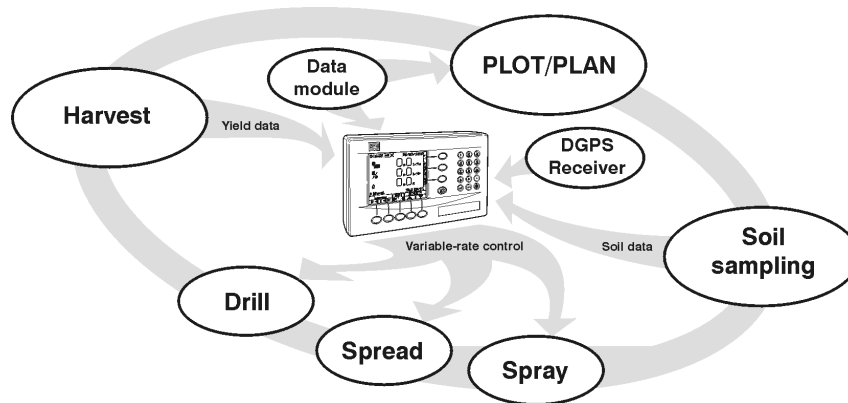

1.2 Installation and Inter-operability with other systems

An RDS control system comprises several component kits. This modular approach means that a suitable control system can be specified for a very wide range of implements. When re-configured with the appropriate control software, the head unit can be simply transferred between different implements.

The *PS8000i* can also output variable-rate instructions to other control systems including Vicon, Bogballe and Amatron systems, as well as acting on variable-rate instructions received from Fieldstar, Soy! Opti, Agrocom ACT, JD Greenstar, Raven and Hydro-N Sensor systems.

1.3 Control Software

Your *PS8000i* instrument is pre-loaded with "Delta 34i" sprayer control software only.

With the purchase of a "secondary software module" - an electronic chip loaded into the back of the instrument, the Pro-Series can be instantly switched to perform another function e.g. from a Sprayer Controller to a Data Logger for route navigation and soil mapping tasks. This is done from "Instrument Select" in the "USER OPTIONS" menu.

There are software modules for yield monitoring/mapping, route/soil mapping, variable-rate sprayer control, variable-rate belt spreader control, variable-rate disc spreader control, and variable-rate seed drilling.

For information on connecting and configuring RDS PF hardware e.g. the Secondary Software Module, DGPS Receiver, cables etc, and data transfer to your PC, please refer to the "Data Logging and Transfer" manual.

1.4 Control System

Closed loop control

The Delta 34i is a single channel controller, operating a control system comprising either a flow sensor [1] or pressure sensor [2], or both*, and one of several types of control valve [3] to enable closed loop control.

* With both sensors installed, the system can be configured so that it switches automatically between flow-based and pressure-based regulation as required. This enables accurate application over a wider range of operating conditions than is otherwise possible with a single sensor.

Proportional control

Also, forward speed measurement and boom section sensing enables full *proportional* control, i.e. to maintain a set application rate irrespective of forward speed (within limits) or part width spraying.

The forward speed sensor may be fitted either to the tractor/self-propelled sprayer or a trailed sprayer. It may be either a simple magnetic sensor measuring wheel or propshaft rotation [4], or a radar sensor [5]. Speed measurement via a GPS VTG message is also an option.

The boom section status is detected via the sprayer interface cable [6] connecting into the existing sprayer switchbox.

Figure 2 The 'Delta 34' control system

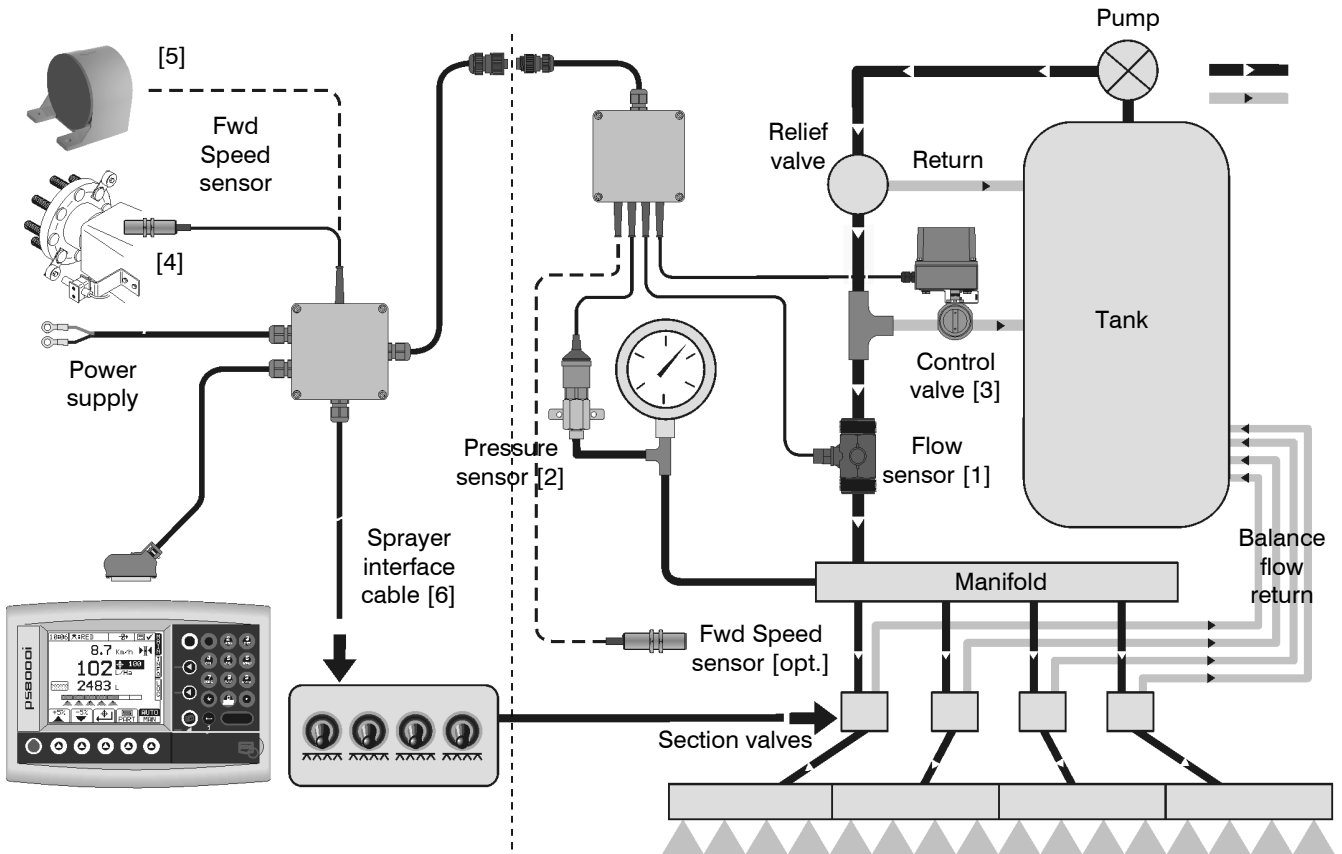

System configuration

The PS8000i can be configured to accurately control any sprayer, via a range of settings made in the calibration menu on initial installation. These settings are normally made by a technician, and should not need to be adjusted during normal operation. They are described in the separate Calibration manual supplied.

During normal operation, the operator needs only to set/calibrate the system for the product being applied and the nozzles fitted. The operator can also 'fine-tune' the product calibration to account for variations in field conditions. These calibration procedures are described in this manual.

1.5 Sprayer Control Modes

1.5.1 Dual Spray Line Control

Dual spray line control is an option selectable in the setup menu. It enables a wider range of flow rates to be applied than while maintaining a given spray quality, on sprayers equipped with dual spray lines, each of which has a different size spray nozzle fitted.

The instrument determines the required flow rate for a required application rate, and automatically switches between line 'A', line 'B' or both lines, according to the nozzles types fitted. It then regulates the pressure to achieve the target application rate.

For either single spray line or dual spray line setup, the *Delta 34i* has three control modes.

1.5.2 Automatic Control Mode

This gives fully automatic rate control. Flow / pressure is automatically regulated as forward speed varies, to ensure that the actual application rate constantly matches a preset target rate. The application rate can be manually nudged up and down from the target rate as required for spot application in specific areas. Programmable alarms warn of high and low flow rates.

Field data ("job summaries") can be logged and are stored in the instrument memory. Up to 75 summaries can be stored. If you have a GPS receiver connected, as well as creating a job summary, you can also log the vehicle route and application data to a "dynamic log" file on the SD memory card. The job summary data is also appended to this file, which can be viewed using PC-based Precision Farming software programs.

1.5.3 Manual Control Mode

This gives simple manual control of application rate. Field data ("job summaries") can be logged and are stored in the instrument memory. Up to 75 summaries can be stored.

1.5.4 VRT (Variable-rate treatment) Control Mode

This enables the system to be controlled via treatment instructions prepared using PC-based Precision Farming software programs, in conjunction with DGPS position data. To enable fully automatic variable-rate treatment for Precision Farming applications, the *PS8000i* requires a suitable DGPS receiver and suitably formatted SD memory, card to implement treatment plans generated using PC-based Precision Farming software programs.

A work record file is automatically created on the SD card to log data confirming the actual treatment. The job summary data is also appended to this file, which can be viewed using PC-based Precision Farming software programs. Please refer to the "Data Logging and Transfer" manual Pt No. S/DC/500-10-573 for details of DGPS installation, setup and data transfer with the PC.

1.6 The Head Unit Keypad

1.6.1 Menu keys

All instrument functions are accessed via the menu keys adjacent to the LCD display.

The four menu keys to the right of the screen (figure 3) access the primary screen pages (those viewed during normal operation). There are two primary screens, MAIN and INFO for normal operating functions, and a SETUP screen for calibration functions.

The five sub-menu keys below the screen control the various display functions and settings for each of the primary screen pages. Text or icons are displayed adjacent to the sub-menu keys to denote their function.

Figure 3

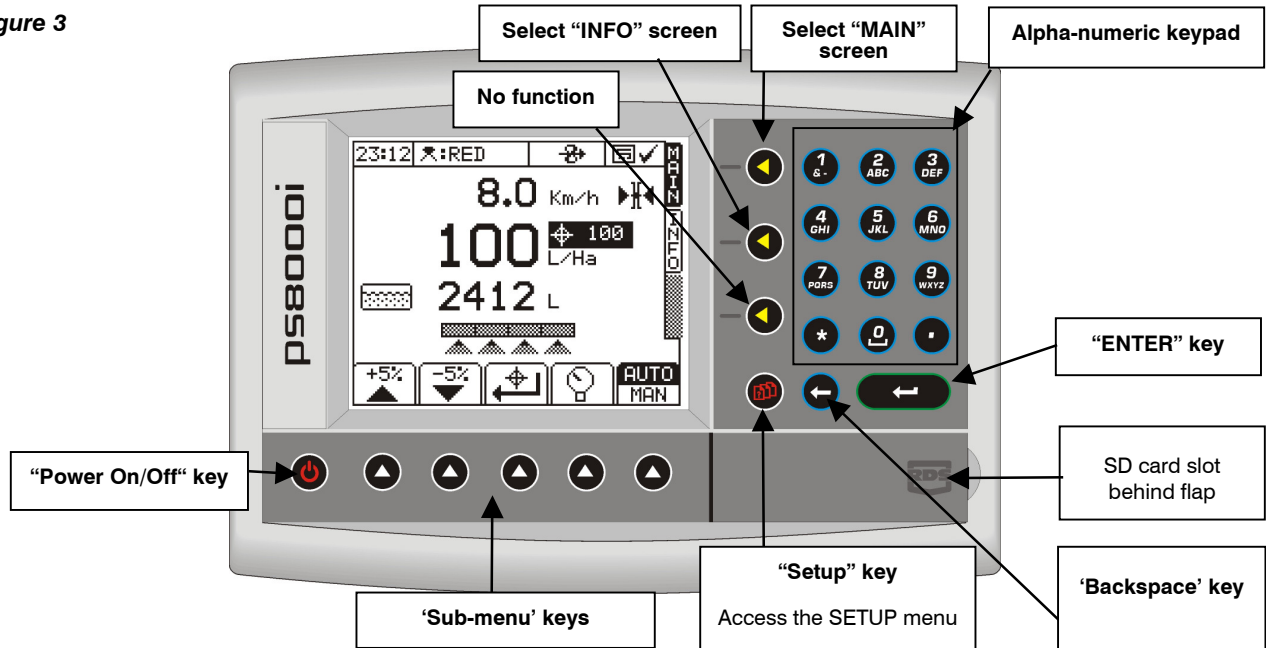



1.6.2 Startup

Press the  key. The startup screen, which shows the software version, will display for about 8 seconds then the MAIN screen is displayed.

1.6.3 Data Entry

Alpha-numeric values are entered via the right-hand keypad. You must press the key from 2 to 5 times to select the required letter. (Some keys have additional special characters not shown on the key legend).

The  key will either toggle between lower and upper case characters, or when preceding a numerical entry, sets a MINUS value.

The  key will toggle between 0 and a SPACE.

The  key will BACKSPACE the screen cursor if you need to re-enter a character.

The  key is the ENTER key and is normally pressed to confirm the data entry into memory.

1.7 The MAIN screen page

The instrument will always default to the MAIN screen on startup. The MAIN screen displays the following information.

Figure 4

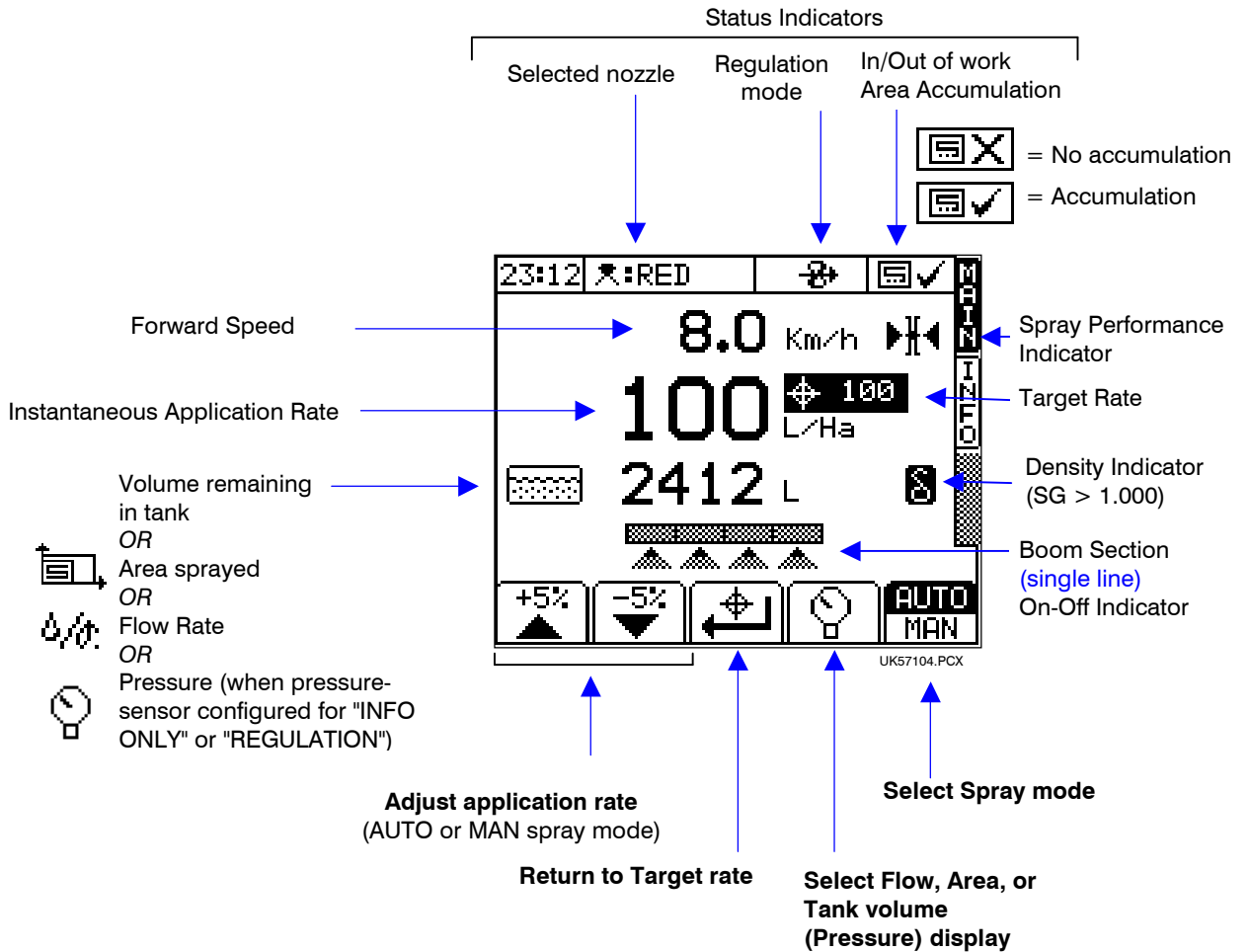

1.7.1 Target Rate Indicator

The target rate is displayed by the graphic in 'AUTO' spray mode. If the application rate has been adjusted above or below the target rate, then the target rate will be flashing.

Pressing the key will return to the pre-programmed target rate.

There is no target rate icon in 'MAN' spray mode.

1.7.2 Spray performance Indicator

The Spray performance Indicator shows the nozzle performance within the minimum and maximum parameters displayed on the Nozzle Wizard page. The "Target Speed" is at the middle of the speed range.

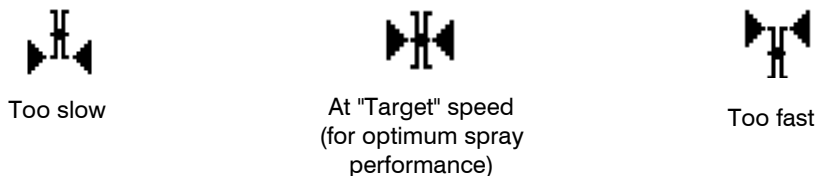

For optimum nozzle performance and spray pattern you should maintain your forward speed as close to the "target" speed as possible.

1.7.3 MAIN Screen Display Options

You can select which function is displayed on the third line of the MAIN screen. Press the sub-menu key to cycle through the following functions:

Figure 5

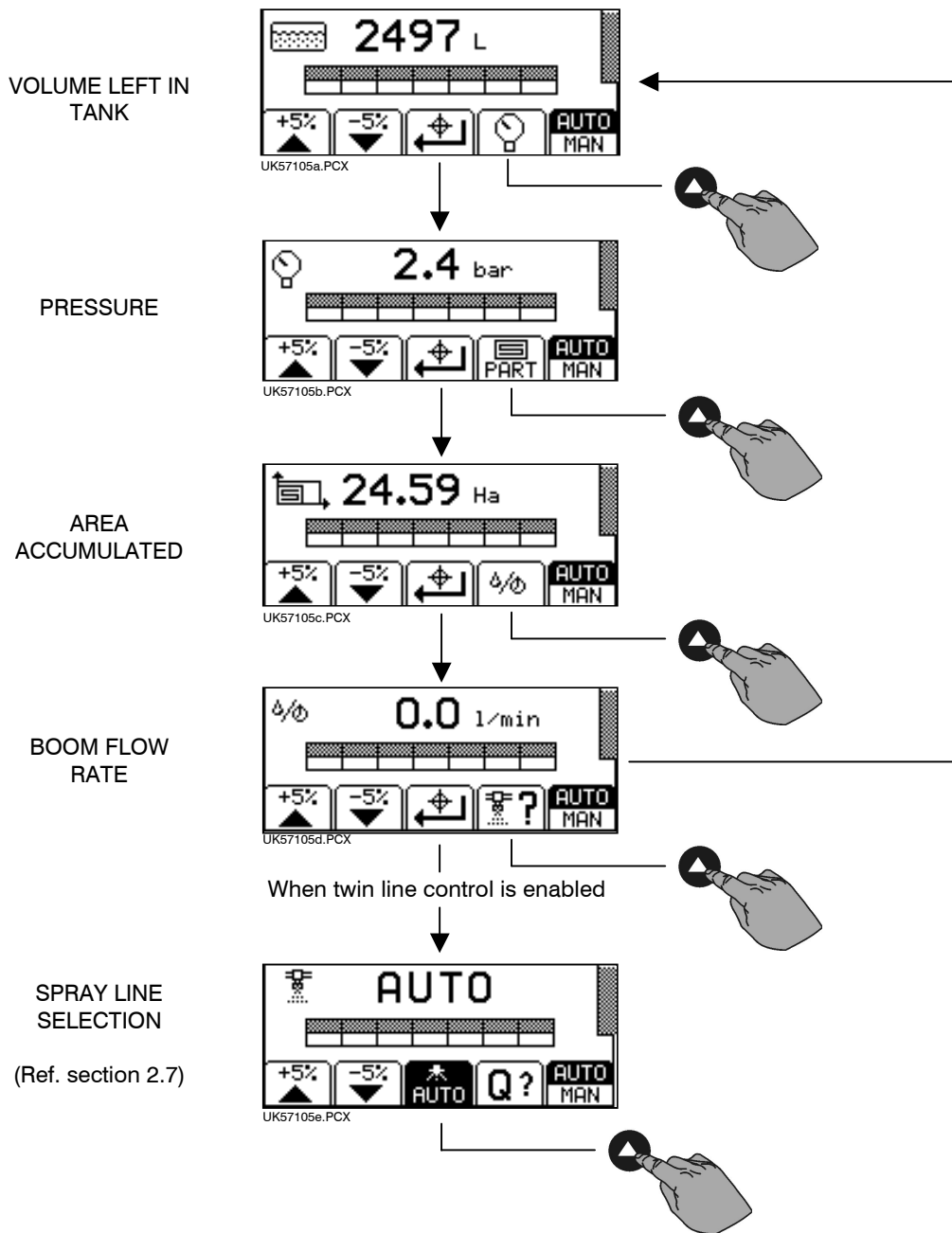

1.8 The INFO screen page

Additional work measurement functions are displayed on this page.

Figure 6 The INFO screen

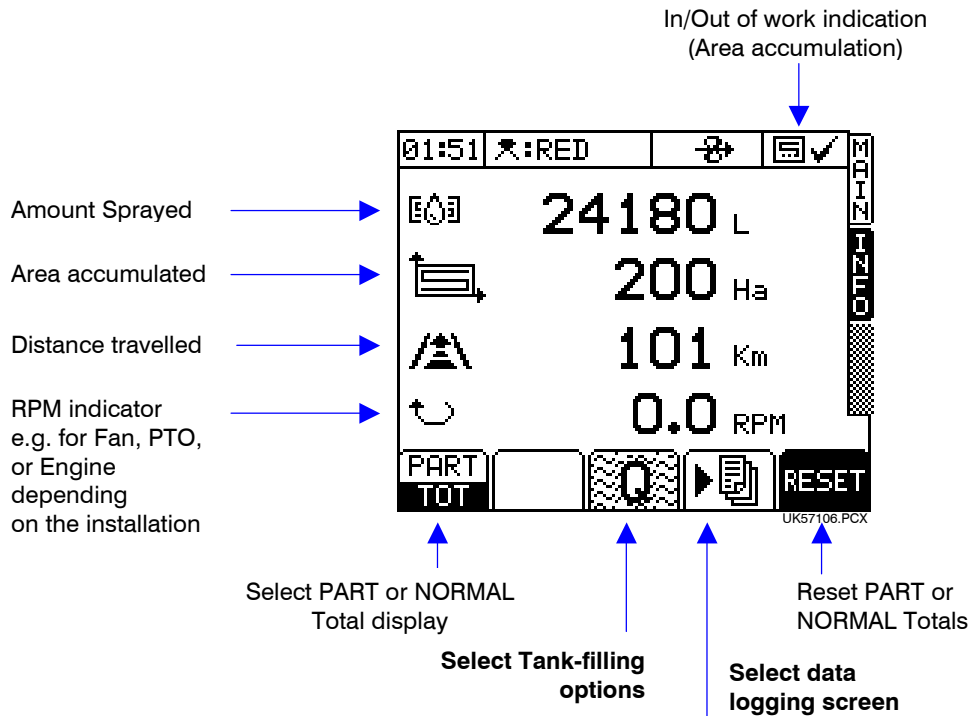

1.9 The LOG screen page

This page controls data logging (Field Summary data), and P.F. functions, and data transfer (e.g. printing a job summary).

Figure 7 The LOG screen

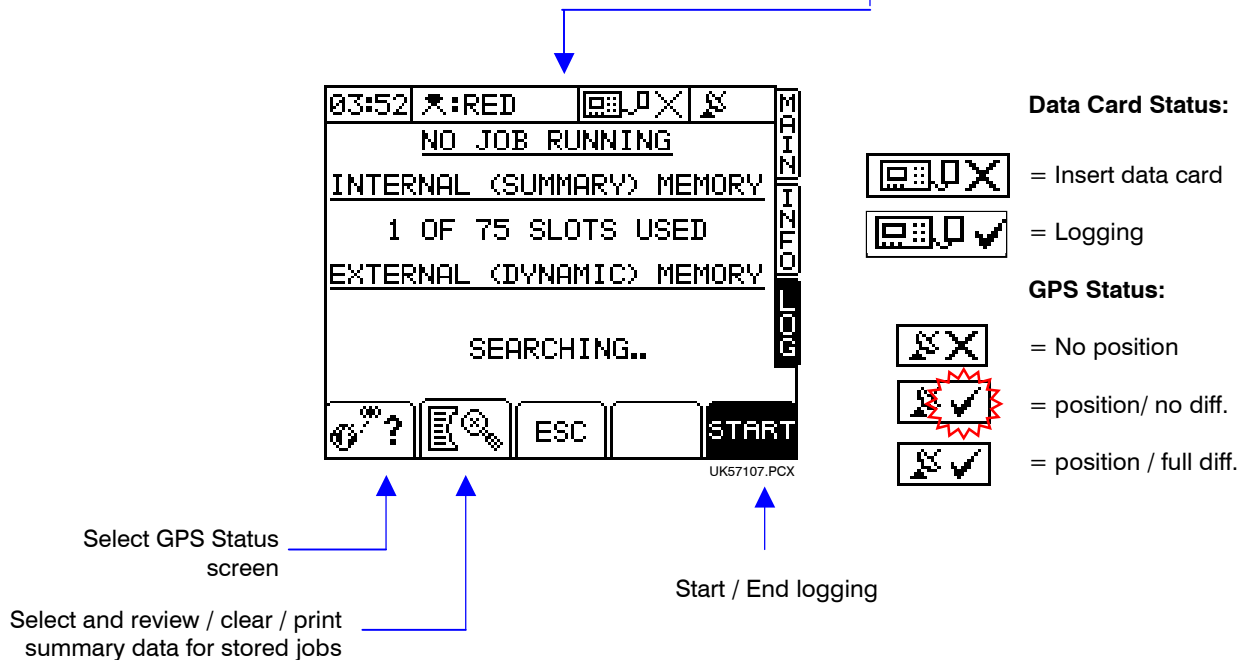

Please refer to the “Data Logging and Transfer” manual for further information.

1.10 The SETUP screen page

The  key selects the SETUP menu for calibration factors and calibration settings specific to particular products being sprayed and nozzle types fitted.

Figure 8 The SETUP screen



You should not need to enter menus 1, 2 and 3 in normal use. These settings are generally made only on initial installation. Menus 2 and 3 can be protected with a personalised PIN number to prevent unauthorized access. Calibration settings that need to be changed during normal use are shown on figure 8.

1.11 Units

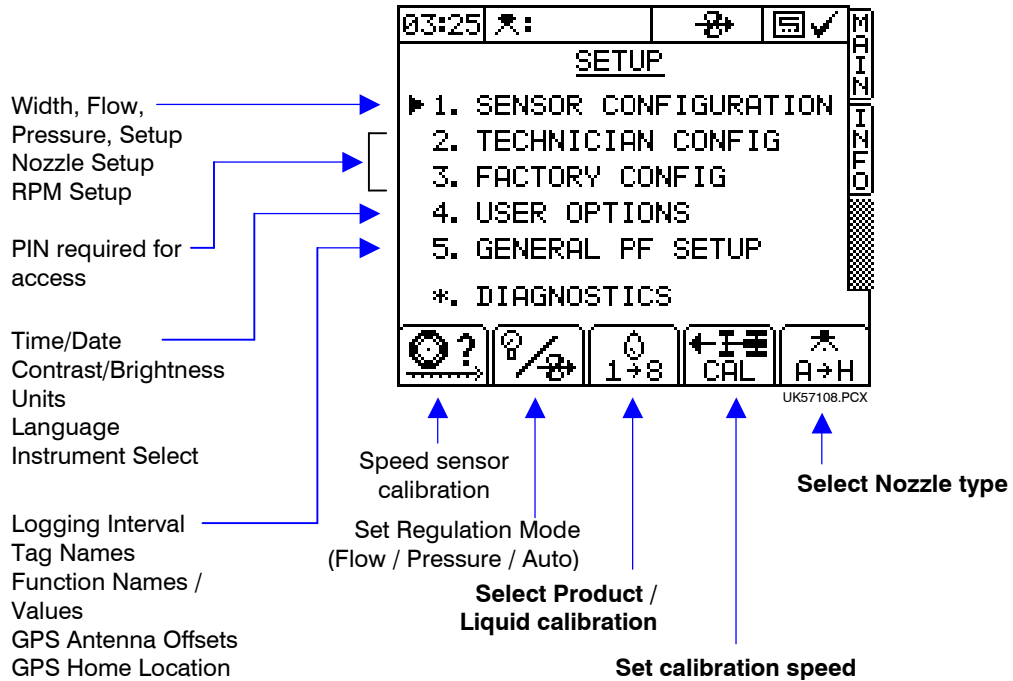
Information can be displayed in Metric or Imperial units by selecting the desired option via the SETUP menu.

Function	Units	
	Metric	UK Imperial
Forward Speed	km/hr	miles/h
Application rate	litres/ha kg/ha tonnes/ha m ³ /ha ml/m ²	gallons/acre lbs/acre tons/acre kgals/acre floz/ft ²
Flow rate	litres/min	gallons/min
Part/Total Area	hectares	acres
Tank volume/ Part/Total volume applied	litres	gallons
Spray pressure	bar	lbs/in ²

2. Operation

2.1 Setting the target rate and target speed

Firstly, establish the lower and upper limits of forward speed and application rate at which spraying will be performed, and the optimum application rate and forward speed - i.e. the base rate and average speed.

NOTE: To illustrate the general procedure for the following sections, let's use the example that you want to spray anywhere between 100 - 200 litre/hectare with a base rate of 150 l/ha, and your forward speed will vary between 8 and 16 km/hr with a target speed of 12 km/hr.

1. From the SETUP page, press  .

2. Key-in the speed (12 km/hr) and press  to set the target speed.

NOTE: The target speed is also the simulated speed used during nozzle calibration. Setting a target speed starts speed simulation, and remains in effect until either you press the  key, or move the vehicle a short distance.

The display will revert to the MAIN screen and the  icon will start flashing.

3. From the MAIN screen, key-in the target application rate and press  .

2.2 Selecting the Nozzle size

2.2.1 Single Spray Line

The 'Nozzle Wizard' page shows you how a selected nozzle will perform in order to achieve the Target Application Rate at a programmed Target Speed. The operating range of the nozzle is based on the target speed.



1. From the SETUP page, press  to view the 'Nozzle Wizard'.

Figure 9

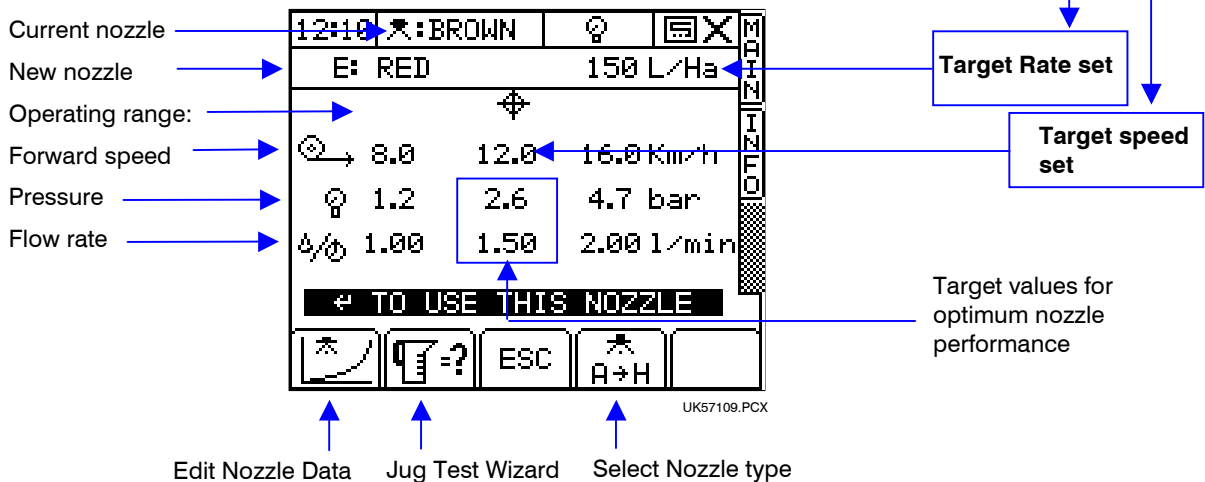

There are 8 pre-programmed, ISO standard nozzle types A to H ;

Type	Colour
A	Orange
B	Green
C	Yellow
D	Blue
E	Red
F	Brown
G	Grey
H	White

2. Cycle through the nozzles with the  key until a nozzle found with a target pressure (see fig. 9) closest to the reference pressure (normally 3 bar) and press  . In this example it is the RED nozzle for 150 l/ha @12 km/hr.
3. Fit the appropriate nozzles to the sprayer.

2.2.2 Dual Spray Line

- From the 'Nozzle Wizard', select Spray line 'B'  - (the larger of the two nozzles).

Figure 10





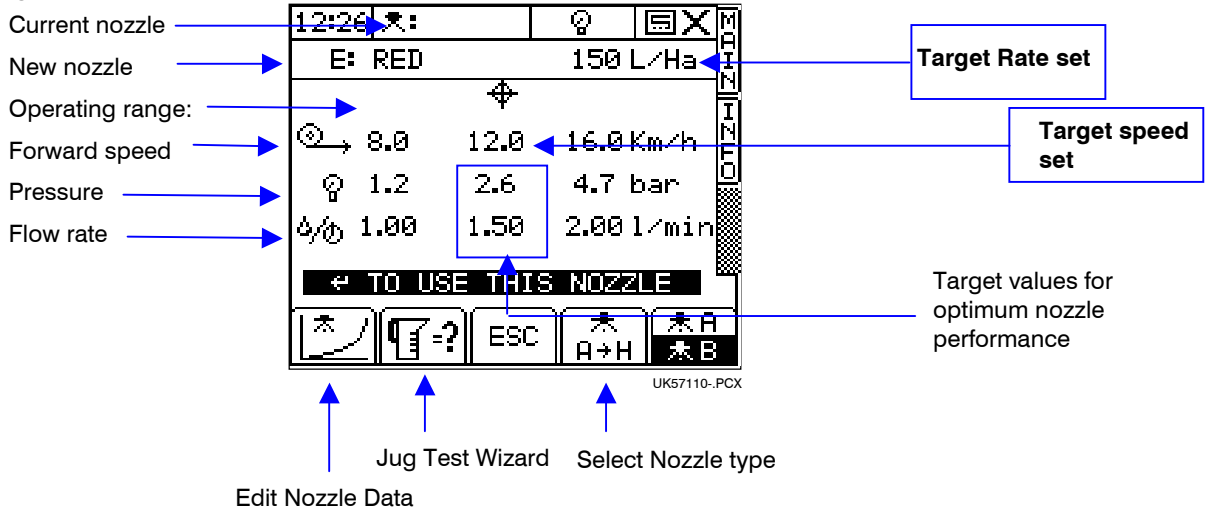

- Cycle through the nozzles with the  key until a nozzle found with a target pressure (see fig. 10) closest to the reference pressure (normally 3 bar) and press . In this example it is the RED nozzle.
- Select Spray line 'A'  - (the smaller of the two nozzles) and select a nozzle **two** sizes below the large nozzle (i.e YELLOW) and press .

Figure 11



Now it's a case of checking to see that the combination of nozzles are OK over the range of application rate and speed.

- Set the *minimum* rate and speed (100 l/ha + 8km/hr) as per section 2.1. Re-select the Nozzle Wizard and select line 'A'. You will see that the pressure will be 2.1 bar (fig 12a), so the YELLOW nozzle should be OK.
- Set the *maximum* rate and speed (200 l/ha + 16km/hr) as per section 2.1. Re-select the Nozzle Wizard and select line 'A+B'. You will see that the pressure will be 3.7 bar (fig.12b), so the YELLOW (A) + RED (B) combination should be OK.

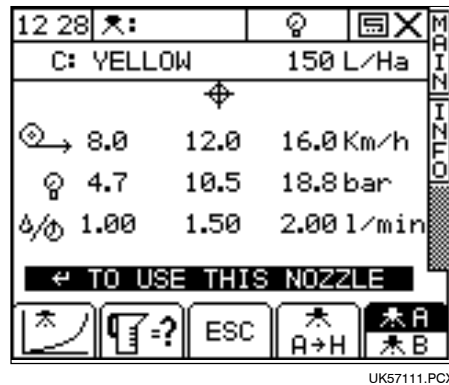
Figure 12a

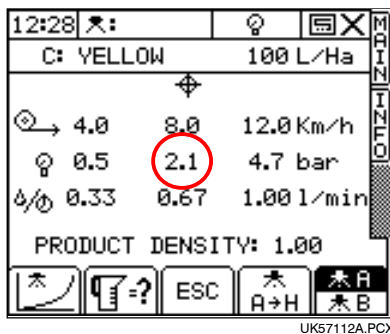
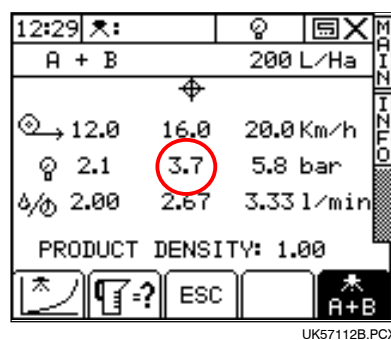

Figure 12b



NOTE: The operator should finalise the choice of nozzles based on their own judgement. You are also reminded of the disclaimer regarding use of the system (paragraphs 1 to 4 on page 2 of the manual).

2.2.3 Editing the preset Nozzle type

If the nozzles fitted do not correspond to any of the 8 preset types, then you must select one of the nozzle types A to H and edit the calibration data according to the nozzle manufacturers data.

1. Press the  on the Nozzle Wizard and select the nozzle to edit..

Figure 13b: Nozzle edit screen



UK57113.PCX

2. Edit the nozzle name and change the values according to the nozzle manufacturers data sheet.

2.3 Selecting the Regulation Mode

The current regulation mode is displayed at the top of the operating screens.



Flow-based regulation active



Pressure-based regulation active

The Delta 34i normally operates as a flow-based system. Assuming a pressure sensor is installed in addition to the flow turbine sensor, you can select either flow-based regulation, pressure-based regulation, or the system can be set to automatically switch between flow-based and pressure-based regulation as required to maintain satisfactory spraying performance.

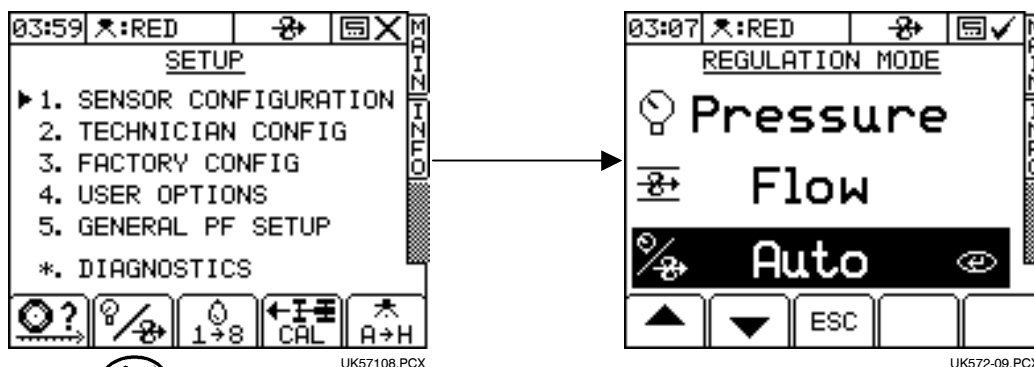

Flow-based systems requiring high application rates for liquid fertiliser application, require a large flow sensor to be installed. However, this turbine may not be as accurate at lower application rates required for chemical applications. Where a large turbine is fitted, it is advantageous for the regulation mode to be set to 'AUTO'. The system will automatically switch to pressure-based regulation when the flow rate drops below the programmed minimum flow rate of the flow sensor.

Figure 13b: Switching between flow-based and pressure-based regulation



UK57108.PCX

UK572-09.PCX

1. From the SETUP screen, press the  button. (this only appears on the SETUP screen when both sensors are enabled).
2. Select "Pressure", "Flow" or "Auto" using the up / down arrow keys and press  to confirm.

2.4 Product presets

You can select any one of up to eight different product presets via the 'PRODUCT SELECTION' screen. For each preset, you can programme the product name and density, or perform/adjust the volume calibration as follows,

2.4.1 Selecting a product



1. Press the  key and then press the  key (fig. 8).
2. Select the product using the arrow keys (default names are 'Spray A' to 'Spray H') and press  to confirm.

Figure 14a



Figure 14b

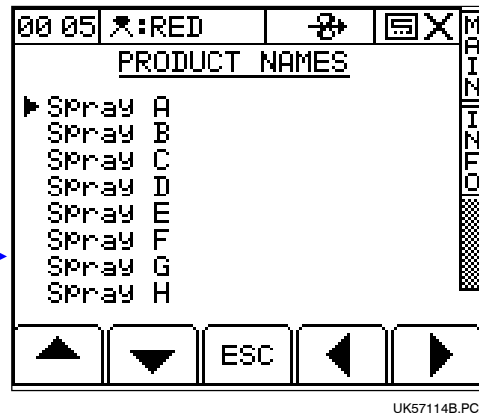

3. Press the MAIN key to return to the "MAIN" screen page.

2.4.2 Editing a product name

The 8 default product descriptions are 'Spray A' to 'Spray H'.





From the 'PRODUCT SELECTION' screen, press the  key to select the 'PRODUCT NAMES' screen (fig. 14b).

Select the product name using the arrow keys, and edit the name using the alpha-numeric keypad.

2.4.3 Programming a product density

You must programme the correct density when spraying fertilisers. The system will then automatically compensate in order to maintain the correct application rate and spray performance.

Whenever the programmed density for the selected product is anything other than 1.00 the instrument will display the  icon on the main screen.

1. Press  to select the "SETUP" screen.
2. Press  to select the "PRODUCT SELECTION" screen (fig 8).
3. Select the "DENSITY" line, key-in the correct density and then press .
4. Use the "ESC" key or press  to return to the "SETUP" screen, (or press the MAIN key to return to the 'MAIN' screen).

NOTE: The programmed flow rate resulting from the liquid calibration routine, is always for water, even though the product being sprayed has an S.G > 1.000.

2.5 Automatic Rate Control



Select 'AUTO' from the 'MAIN' screen. The flow rate will be automatically adjusted as forward speed and/or applied width varies, to ensure that the application rate constantly matches the preset target rate.

2.5.1 Setting the Target Rate

From the "MAIN" screen simply key-in the desired target rate and press .

2.5.2 Overriding the Target Rate

1. Press to override the target rate.

The preset target rate can be overridden in $\pm 5\%$ steps while spraying, e.g. over localised weed infestation or other crop conditions.

While overridden, the target rate indicator will flash.

2. Press to return to the target rate.

The instrument will automatically alarm if the application rate cannot be maintained within a specified % of the target rate (the % band is programmed via the 'Alarm Setup' screen in the Setup MENU).

When the alarm threshold is reached, the instrument beeps, and an alarm screen displays the message "UNDER APPLICATION" (e.g if the forward speed is too high), or "OVER APPLICATION" (e.g. if the forward speed is too low).

Pressing any of the lower 'OK' keys will cancel the alarm screen and return to the 'MAIN' operating screen.

NOTE: *If you continue spraying at the same speed, the instrument will not automatically re-alarm. It will however, re-alarm if the sprayer is switched off and back on again.*

2.6 Manual Rate Control



You do not normally need to select this mode, however in the event you experience a problem with automatic control (if for example the forward speed sensor had stopped working), you can still control the application rate manually.

Select 'MAN' from the 'MAIN' screen. To maintain the required application rate, you must maintain a constant forward speed. You can also log and store field data ("job summaries") as you go, and print them out or download them to a PC or printer when convenient.

Press to adjust the application rate.

NOTE : *The speed range indicator functions as normal, however there is no forward speed or rate alarm in manual mode.*

2.7 Dual Spray Line Control in AUTOMATIC or MANUAL mode

If set up for dual spray lines, in either spray regulation mode 'AUTO' or 'MAN', you can choose for the system to automatically select the spray lines 'A', 'B' or 'A + B' in use according to the spraying parameters, or manually select the spray line(s) in use.

1. From the MAIN screen, press the inner-right menu key (fig.15a) until the SPRAY SELECTION display appears. The display will show the current setting for spray line control.

Figure 15a

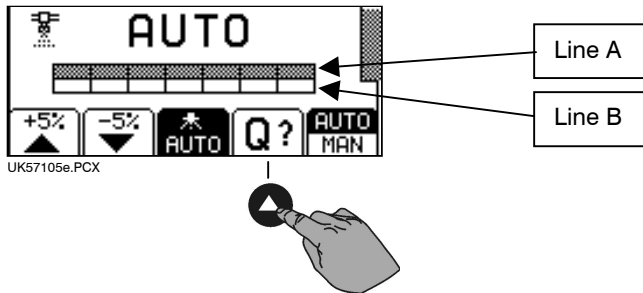

2. In either 'AUTO' or 'MAN' regulation mode, to change the setting, press the centre key to cycle through the options (see note 1).

Figure 15b

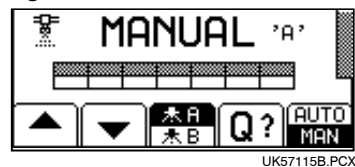

Figure 15c





Figure 15d



'AUTO' - both spray lines are under automatic control. As the forward speed increases or decreases, the system decides which line(s) are in operation in order to maintain the programmed application rate and optimum spray quality.

'MANUAL A', 'MANUAL B', 'MANUAL A + B' - manual spray line selection.

Remember, with manual spray line selection in 'AUTO' regulation mode (), the system still regulates to the target application rate automatically, although the actual application rate and spray quality may be constrained by the nozzles in use. You can continue to select another display option (1.7.3) and the spray line selection remains at the chosen setting until you change it again.

NOTE 1: When in 'AUTO' mode, the  key (return to target rate) is replaced by the spray line select function.

Pressing the inner-right key to select a different display function, re-displays the  key.

2.8 Tank Contents

The Delta 34i automatically calculates the volume of liquid remaining in the tank. The calculation is based on the full tank volume programmed via the "INFO" screen. You can also programme an alarm threshold so that the instrument will warn you when the tank volume is getting low.

When the alarm threshold is reached (e.g. 200 litres), the instrument beeps, and an alarm screen displays the message '**TANK LOW**'. Press any of the lower 'OK' keys to cancel the alarm screen and return to the 'MAIN' operating screen.

The screen will change to show the alarm screen and the message '**TANK EMPTY**' once the tank contents register reaches zero.

The tank contents register must be reset manually after re-filling the tank unless your system includes the optional Tank Inflow Sensor and Flow Shutoff Valve. When fitted this enables the instrument to automatically monitor re-filling and cut off the inflow when the tank is full.

2.8.1 Tank fill (manual)



1. Refill the tank to the desired level.
2. Select the "INFO" screen and press  to access the TANK FILL screen (fig. 16). The screen will display,
 - "MAX" - the full tank volume
 - "NOW" - the volume remaining in the tank
 - "TO ADD" - volume to replenish

Figure 16 Tank fill screen



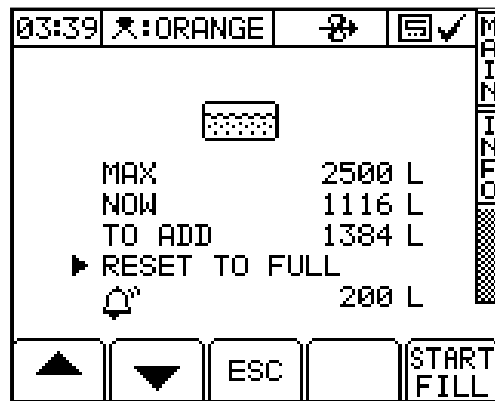

UK57116.PCX

3. If refilling the tank to capacity, then select '**RESET TO FULL**' and press ENTER.
4. Confirm that "**MAX**" corresponds to the quantity in the tank. Adjust as necessary.
5. If partly filling the tank, select '**NOW**' and enter the part volume in the tank, then press ENTER.
6. Confirm the alarm volume () is OK (typically the volume needed to spray a single bout). Adjust as necessary.

2.8.2 Tank filling (Automatic)

A Tank Inflow Sensor must be installed to measure the inflow. A Shutoff Valve must be installed to stop the filling automatically.

1. Connect the inflow hose.
2. Select the "TANK FILL" screen as above.
3. Confirm that "**MAX**" corresponds to the quantity you want in the tank after filling. Adjust as necessary.
4. Confirm that the "**NOW**" volume is the volume currently in the tank. Adjust as necessary.
5. Confirm the alarm volume as above.
6. Press the  key.

The "**TO ADD**" volume will then count down and the screen will display "**STOP INFILL**". If a Shutoff Valve is fitted, filling will cease automatically when the "**TO ADD**" volume reaches zero. You can also press  at any time to stop filling. An audible alarm will sound and filling will stop.

2.9 Part / Total Accumulation and RPM display

You can record the area and volume sprayed for a particular job using the "PART" Total function. In addition the area and volume will be recorded to the "TOTAL" memory register.

Select the "INFO" screen to display the accumulated totals and the RPM display.



Select 'PART' to display the Part Area and Part Volume accumulation,



Select "TOTAL" to display the Total Area and Total Volume accumulation.

2.9.1 Reset Totals

Select the "PART" or "TOTAL" display.

Press the **RESET** key.

Press  to zero the totals or press **ESC** to return to the "INFO" screen.

2.10 Alarms

There are a number of alarms, most being programmable by the operator. Note that setting alarm limits to zero will disable that alarm function.

Press any of the lower 'OK' keys to cancel an alarm and return to the MAIN screen.

Application Rate	'UNDER APPLICATION' 'OVER APPLICATION'	This alarm is based on % variance from the target rate. It therefore alerts the operator to speed up or slow down until the alarm condition is cancelled. The limits can be set by the operator on the 'Alarms Setup' screen in the SETUP menu. The default limits are $\pm 20\%$ of the target rate.
The following alarms can also be configured if so desired, but would normally be overridden by the application rate alarm if set (except for RPM alarm). The limits must be set in respect of flow sensor capacity / spray performance.		
Forward Speed	'FORWARD SPEED LOW' 'FORWARD SPEED HIGH'	The limits can be set by the operator on the 'Alarms Setup' screen in the SETUP menu.
Flow Rate <i>(Alarm effective in flow-based regulation mode only)</i>	'FLOW LOW 1' 'FLOW HIGH 1'	The limits can be set by the operator on the 'Alarms Setup' screen in the SETUP menu. They must be set correctly to suit the size of flow sensor fitted, and to ensure that the system switches properly between flow-based regulation and pressure-based regulation, if the instrument is operating in the 'AUTO' regulation mode. NOTE: These limits are also displayed on the 'Flow Sensor' setup screen in the SETUP menu.
Pressure <i>(Alarm effective in pressure-based regulation mode only)</i>	'PRESSURE LOW' 'PRESSURE HIGH'	The limits are those calculated and displayed on the nozzle wizard screen. They are not programmable by the operator.
RPM	'RPM LOW' 'RPM HIGH'	The limits can be set by the operator on the 'RPM Setup' screen in the SETUP menu.

'FLOW HIGH 1' may be caused by the control valve being unable to dump sufficient flow back to the sprayer tank as a result of:- speed too slow or stationary, too small or too few nozzles in use - sections off or blocked nozzles, pump capacity too large or control valve too small.

'FLOW LOW 1' may be caused by:- forward speed too high, insufficient pump capacity, low pump speed, low or empty tank, blocked filters or incorrect jets.

2.10.1 Setting the Alarm thresholds

1. Press  to select the "SETUP" menu.
2. Select the "ALARMS SETUP" screen (fig.17).

Figure 17



3. Select the appropriate alarm threshold using the arrow keys, and enter the value via the numeric keypad.

3. Liquid calibration

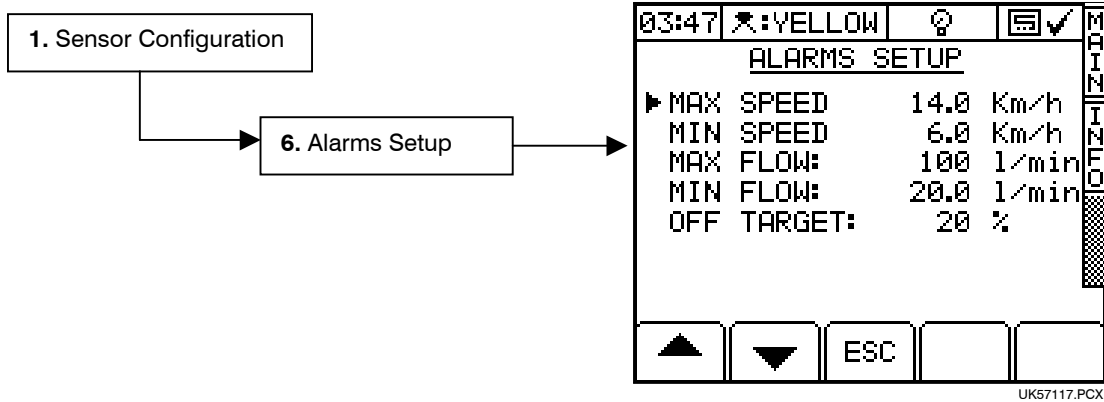
It is important to ensure that the flow / pressure sensors have been properly configured (ref. Calibration manual) before doing a liquid calibration.

NOTE: *Liquid calibration is always done with water. When spraying denser liquids such as liquid fertilizers, after doing the jug test you should programme the correct density for that product, from the "PRODUCT SELECTION" screen (section 2.4.1).*

3.1 Initial Calibration - using the "Nozzle Calibration Routine"

The following procedure applies for both pressure-based and flow-based regulation.

1. First set the desired target speed and target rate (ref. section 2.1).
2. Then select the most suitable nozzles using the 'Nozzle Wizard" (ref. section 2.2).

NOTE: *If calibrating twin spray lines,. You must perform the following nozzle calibration routine three times- for Line 'A', then for Line 'B', and finally for Lines 'A' + 'B'.*



3. From the 'Nozzle wizard' screen, first select the appropriate spray line, then press  . The current calibration speed is displayed (fig. 18a).
4. Change the calibration speed if desired, from that displayed and press  to accept. The adjusted speed is used for calibration only and will not change the target speed set. The "CAL TEST" screen is then displayed. It flashes "CAL" to indicate that speed is being simulated, and gives the message "TURN ON NOW" (fig. 18b).
5. Switch the sprayer on. It is better the calibration test is carried out with the full boom spraying, as this reproduces the field conditions and any pressure drops across the system.
6. When a boom section is switched on, the "CAL TEST" screen appears. All parameters will display '- - - -,' Until the control system has stabilized. The screen then displays the calculated application rate and individual nozzle flow rate. If a pressure sensor is fitted, the pressure is also displayed (fig. 18c).

Figure 18a Nozzle calibration routine



UK57118a.PCX

Figure 18b



UK57118b.PCX

Figure 18c

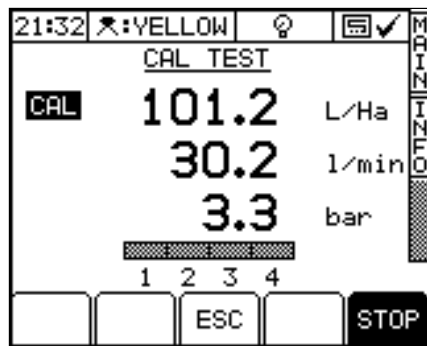

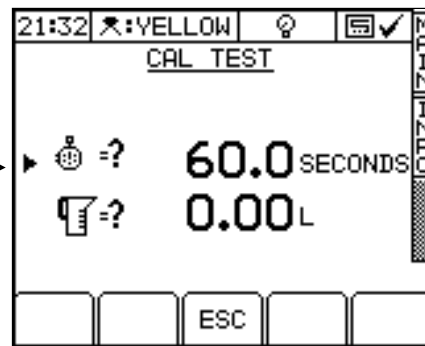

UK57118c.PCX

Figure 18d



UK57118d.PCX

When a steady state is achieved, carry out the jug test by collecting a quantity of water from a single nozzle, and record the collection time

7. Press the 'STOP' key to end the metering period.
8. Enter the actual time the jug was under the nozzle (default = 60 sec) and press  .
9. Enter the test volume (or averaged test volume – see note 1) and press  .

The instrument then calculates and displays the new calibration factors (fig. 19). If you can have both a flow sensor and pressure sensor enabled, you will see both:-

- NOZZLE FLOW RATE in litres/min/nozzle ("REF' FLOW" on the nozzle data page) for pressure-based regulation.
- FLOW SENSOR CALIBRATION FACTOR in pulses per litre for flow-based regulation.

Figure 19 Flow Calibration Factors



NOTE 1 It is advisable to repeat the jug test for several nozzles across the boom and enter the average of the individual test volumes.

10. Press to accept the settings, (or first enter revised figures e.g. the averaged flow rate over a number of jug tests).

If you don't want to accept the calculated result, press ESC to return to the "Nozzle Wizard" screen (fig. 11).

NOTE 2 Performing the jug test changes the previous nozzle flow rate ("REF FLOW") figure stored in the "Nozzle Wizard", and will also correct the calibration factor for the flow turbine.

The jug test is not the most accurate method of calibration particularly for the flow turbine on flow-regulated systems, as the test volume is relatively small. It is therefore recommended to subsequently perform a full-tank calibration, spraying a full tank out in the field.

11. If operating with dual spray lines, perform the calibration test routine separately for line 'A' nozzles, then line 'B' nozzles, and finally both sets of nozzles.

3.2 Full-Tank Calibration

The calibration figure should be subsequently "fine-tuned" after spraying out a full tank in the field. Be certain of the volume sprayed out since the sprayer sight gauge may not be accurate enough for calibration purposes. The liquid calibration should be checked and adjusted regularly over the season to compensate for factors including nozzle wear.







1. From the SETUP page press  to select the "PRODUCT SELECTION" page.
2. If you are spraying clean water or chemicals, check that the product (default name = "Spray A") has density set to 1.00. If spraying liquid fertiliser, check the product and density is selected and programmed.
3. Select the "INFO" screen and reset the "PART TOTAL" to zero.
4. Spray out the whole tank then select the "INFO" screen and note the "PART TOTAL" clocked.
5. Compare this with the known volume sprayed out. If there is a difference between the two figures, then correct the error via the CAL NUDGE screen as follows:
6. Go back to the "PRODUCT SELECTION" page, select "PRODUCT CALIBRATION" and press  (fig. 20).
7. Select "CAL NUDGE" and press  .

Figure 20 Nudging the cal factors

Figure 21

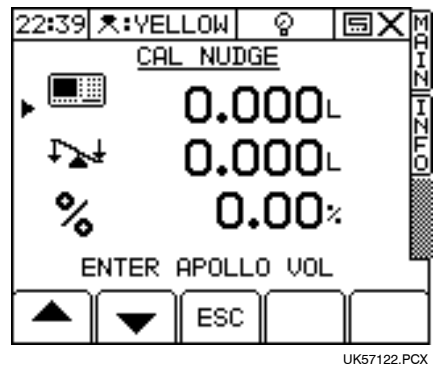
Figure 22

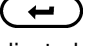

8. Enter the instrument total () and press  , then the known volume sprayed out (), and press  . Finally, press  again to confirm the nudge. The calibration factors are then adjusted accordingly.

Issue 1.00 : 12/2/08

Original issue