

PS 8000

APOLLO / DELTA 34
SPRAYER CONTROLLER

Calibration

RDS Part.No.:	S/DC/500-10-230
Doc. Issue:	3 : 23/7/01
Software Issue:	PS515-002rev4 (Apollo) PS521-000rev10 (Delta 34)

Electromagnetic Compatibility (EMC)



This product complies with Council Directive 89/336/EEC when installed and used in accordance with the relevant instructions.

IMPORTANT, READ THIS BEFORE USING THE APOLLO

The *Apollo* installation is a part of the Precision Farming System ("the System"). It is very important that you follow the described calibration procedures before operating the *Apollo* instrument. Calibration and operation of the *Apollo* must be in accordance with these instructions. Use of the System is subject to the following disclaimer;

- 1. So far as is legally permissible RDS Technology ("RDS"), or its distributors, shall not be liable, whatever the cause, for any increased costs, loss of profits, business, contracts, income, or anticipate savings or for any special, indirect or inconsequential damage whatsoever (death or personal injury excluded).*
- 2. The capabilities and functions of the Precision Farming System ("the System") are limited as set out in the specification of the System, details of which are contained in the Help files and product literature and which must be read before using the System.*
- 3. Without prejudice to the generality of the above it is hereby acknowledged that the System is not designed nor intended to a) originate variable treatment plans or b) achieve or avoid any application rate outside application parameters, which in both cases shall be the responsibility of the operator.*
- 4. The standard terms and conditions of RDS (except clause 7), a copy of which is available on request, apply to the supply and operation of this System.*

Service and Technical Support

PLEASE CONTACT YOUR NEAREST DISTRIBUTOR

If unknown then fax: 44 (0) 1453 733311 for further information.

Our policy is one of continuous improvement and the information in this document is subject to change without notice.

Check that the software reference matches that displayed by the instrument.

© Copyright RDS Technology Ltd 2001

\UK230-3.DTP

CONTENTS

Section 1	Overview		
1.1	Select the Control Software (Apollo only)		5
1.2	The "Setup" Screen page		5
1.3	Data Entry		6
1.4	Control Channels and "Tanks"		6
 Section 2	 Sensor Configuration Menu		
2.1	Forward Speed Sensor		9
2.1.1	Select Wheel Size - 9		
2.1.2	"Auto Cal" - 9		
2.1.3	Manual Calibration - 10		
2.2	Boom Configuration		10
2.2.1	Set Number of Boom Sections - 10		
2.2.2	Set Nozzles per Section and Nozzle Spacing - 11		
2.3	Flow / Pressure Sensor Setup		12
2.3.1	Channel - 12	} Configuration for Flow-based regulation	
2.3.2	Function - 12		
2.3.3	Sensed Width - 12		
2.3.4	Flow Sensor Cal Factor - 13		
2.3.5	Minimum and Maximum Flow - 13		
2.3.6	Start Delay - 13	} Configuration for Pressure-based regulation	
2.3.7	Valve Type - 13		
2.3.8	Channel - 14		
2.3.9	Function - 14		
2.3.10	Calibrate Pressure Sensor - 14		
2.3.11	Changing the Regulation Mode - 15		
2.4	Configuring the Control Valve		
2.4.1	Channel - 16		
2.4.2	Response - 16		
2.4.3	Minimum Pulse - 16		
2.4.4	Deadband - 16		
2.4.5	Startup Delay - 16		
2.4.6	Control - 17		
2.5	Configuring a Tank Filling Sensor		17
2.5.1	Channel - 17		
2.5.2	Calibrating the Sensor - 17		
2.6	Alarms Setup		18
2.6.1	Max. Speed and Min. Speed - 18		
2.6.2	Max. Flow and Min. Flow - 18		
2.6.3	Off Target - 18		
2.7	Nozzle Setup		19
2.7.1	Editing the preset Nozzle Type- 19		
2.8	Calibrating an RPM Sensor		20
2.8.1	Low / High RPM Alarm - 20		
 Section 3	 Flow Calibration		
3.1	Initial Calibration - Using the "Jug Test Wizard"		21
3.2	Full-Tank Calibration.		23

CONTENTS

Section 4	Technician Configuration Menu	
4.1	Display Options	24
4.1.1	Speed Smoothing Factors - 24	
4.1.2	Rate Lock-On - 24	
4.1.3	Rate Smoothing - 24	
4.2	Control Options	25
4.2.1	Nudge Step Size - 25	
4.2.2	Off Target Alarm - 25	
4.2.3	Speed Related Options - 25	
4.3	Boom /Cutout Inputs	25
4.4	Print Calibration Data	26
4.5	Ports Setup - TOP Port (Apollo only)	26
4.5.1	Enabling Printer Output - 27	
4.5.2	Connecting an RDS Data Module - 27	
4.5.3	Receiving VRT Instructions from other Control Systems - 27	
4.5.4	Direct Transfer of Field Data to a PC - 27	
4.6	Ports Setup - BOTTOM Port (Apollo only)	27
4.6.1	Enabling GPS Output - 27	
4.6.2	Sending VRT Instructions to other Control Systems - 27	
4.7	Change PIN for Technician Menu.	27
Section 5	Factory Configuration Menu	
5.1	Machine Options (Apollo only)	28
5.1.1	TANK: Enable / Disable - 28	
5.1.2	TYPE: Type of Machine - 28	
5.1.3	NAME: Edit Tank Name - 28	
5.1.4	SPEED RELATED: Options - 28	
5.2	Total Software Reset.	29
5.3	Backing Up and Restoring Calibration Data	29
5.4	Change PIN for Factory Configuration Menu	29
Section 6	User Options	
6.1	Set Time and Date	30
6.2	Adjust Screen Contrast and Brightness	30
6.3	Set Units	30
6.4	Select Language	31
6.5	Select Control Software (Apollo only)	31
Section 7	General PF Setup (Apollo only)	
7.1	Set Logging Interval	32
7.2	Edit Tag Names	32
7.3	Edit Function Names and Values	33
7.4	Set GPS Antenna Offset	33
7.5	GPS Home Location.	34
7.5.1	Setting the Home Location - 34	
7.5.2	Moving to another location - 35	

1 Overview

The instrument must be calibrated before commencing normal operation. Many settings are made only on initial installation e.g. from the 'SENSOR CONFIGURATION' screen. Other calibration settings may need to be altered on a regular basis according to the liquid being sprayed, nozzle types in use etc.

1.1 Selecting the Control Software (Apollo only)

With the purchase of an optional "software module" which comes in the form of an electronic chip loaded into the back of the instrument, the Pro-Series can be instantly switched to perform another function e.g. from a Sprayer Controller to a Data Logger for route navigation and soil mapping tasks. This is done from "Instrument Select" in the "USER OPTIONS" menu.

1.2 The "Setup" Screen page

Press the  key to select the SETUP menu (fig. 1).

Figure 1
The information displayed on the SETUP screen

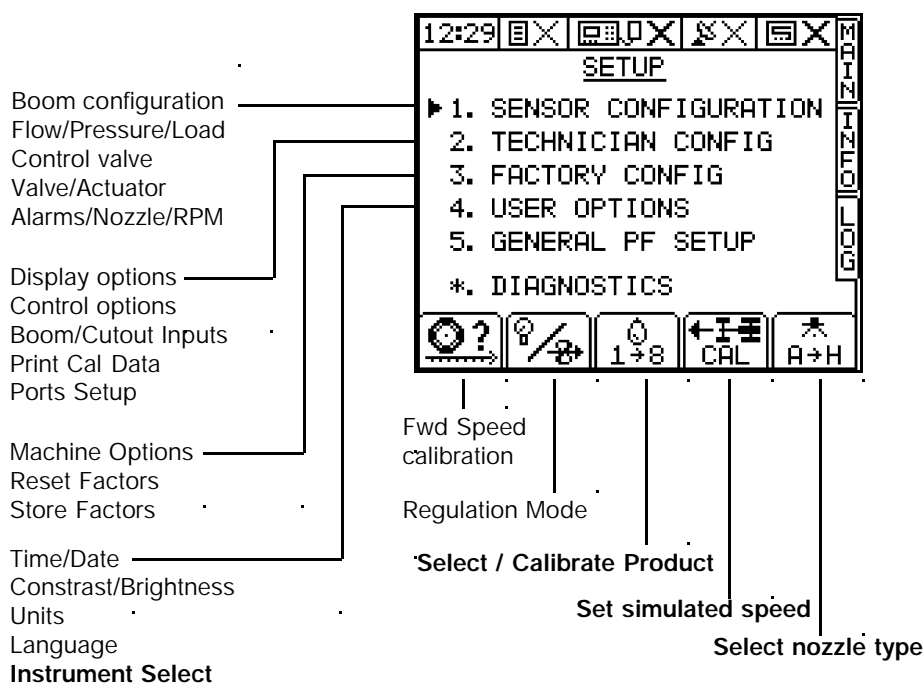

Calibration on installation

Work through the 'SENSOR CONFIGURATION' menu first. Most of these settings need be done only once on installation.

Calibration in normal use

Calibration settings that need to be accessed more frequently are highlighted in bold type on figure 1. These settings include;

- Product calibration
- Tank and Product selection
- Nozzle type
- Speed alarm

1.3 Data Entry

Alpha-numeric values are entered via the right-hand keypad. You must press the key from 2 to 5 times to select the required letter. (Some keys also have additional special characters not shown on the key legend).

The  key will either toggle between lower and upper case characters or when preceding a numerical entry, will set a MINUS value.

The  key will toggle between 0 and a SPACE.

The  key will BACKSPACE the screen cursor if you need to re-enter a character.

The  key is the RETURN key and is normally pressed to confirm the data entry into memory.

1.4 Control Channels and 'Tanks'

The Apollo 8000 is an extremely versatile control system able to simultaneously control via 4 different "control channels" Each "channel" is a full control system comprising a control valve or actuator, and a feedback sensor e.g.

- a sprayer flow control valve and a flow sensor,
- a linear actuator with position (rate) feedback,
- a proportional hydraulic control valve and a flow rate sensor

A 'tank' is the default description for the implement tank or hopper (you can programme your own description accordingly).

Normally there is one control channel per "tank". Occasionally, two control channels are controlling the output of one "tank" e.g. a fertiliser spreader with two actuators controlling left and right sides.

Single implement operation (Apollo / Delta 34)

By default, only 'Tank 1' is enabled. Only one control channel is required for most sprayer control systems.

Except for the boom setup, each 'tank' can be configured for different sprayers, so you can simply transfer the head unit to another sprayer fitted with an RDS distribution system. On changing sprayers, the appropriate 'tank' is enabled from the "Machine Options" screen in the calibration menu. You must re-configure the boom setup as required.

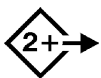

Multiple implement operation (Apollo only)

You can simultaneously control more than one implement e.g. front and rear-mounted spreaders, and all 4 channels can be utilised depending on the total number of valve/actuators/motors in operation.

Additional 'Tanks' are enabled from the 'Machine Options' screen in the calibration menu. The MAIN menu key is then used to cycle between the separate tank display screens and also a screen displaying application rates for all enabled 'tanks'.

NOTES: All "Tanks" must be distributing across the same basic width / boom setup.

This manual predominantly covers single tank operation, however, where applicable, a  symbol indicates information pertaining to multi-tank operation.

Calibration Menu - (Sprayers)

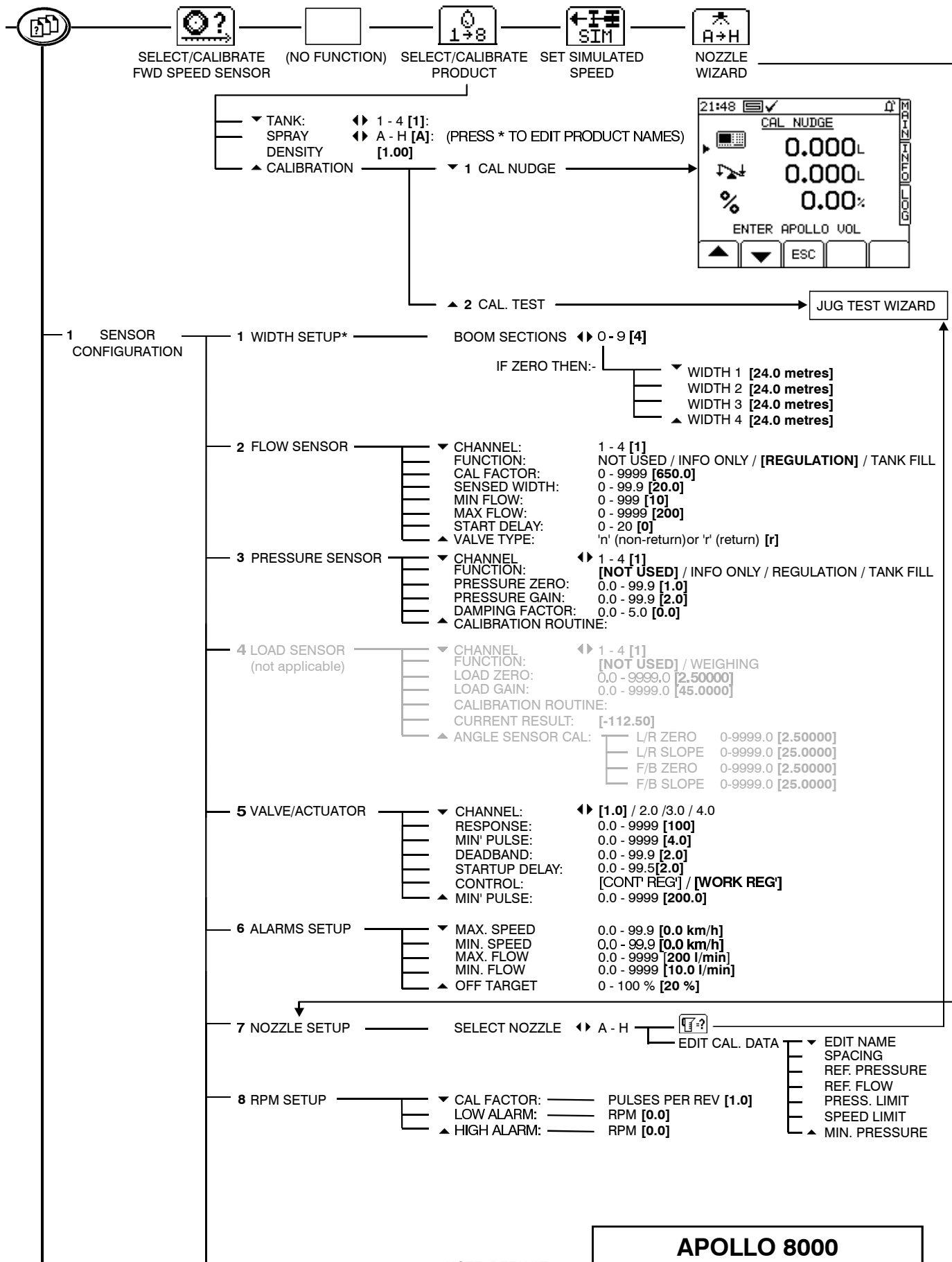

(MENU CONTINUED OVERLEAF)

NOTE: DEFAULT SETTINGS IN BRACKETS []

APOLLO 8000
CALIBRATION MENU
(SPRAYERS)
 SOFTWARE VERSION PS515-002 rev. 25

Calibration Menu - (Sprayers)

FROM SETUP MENU

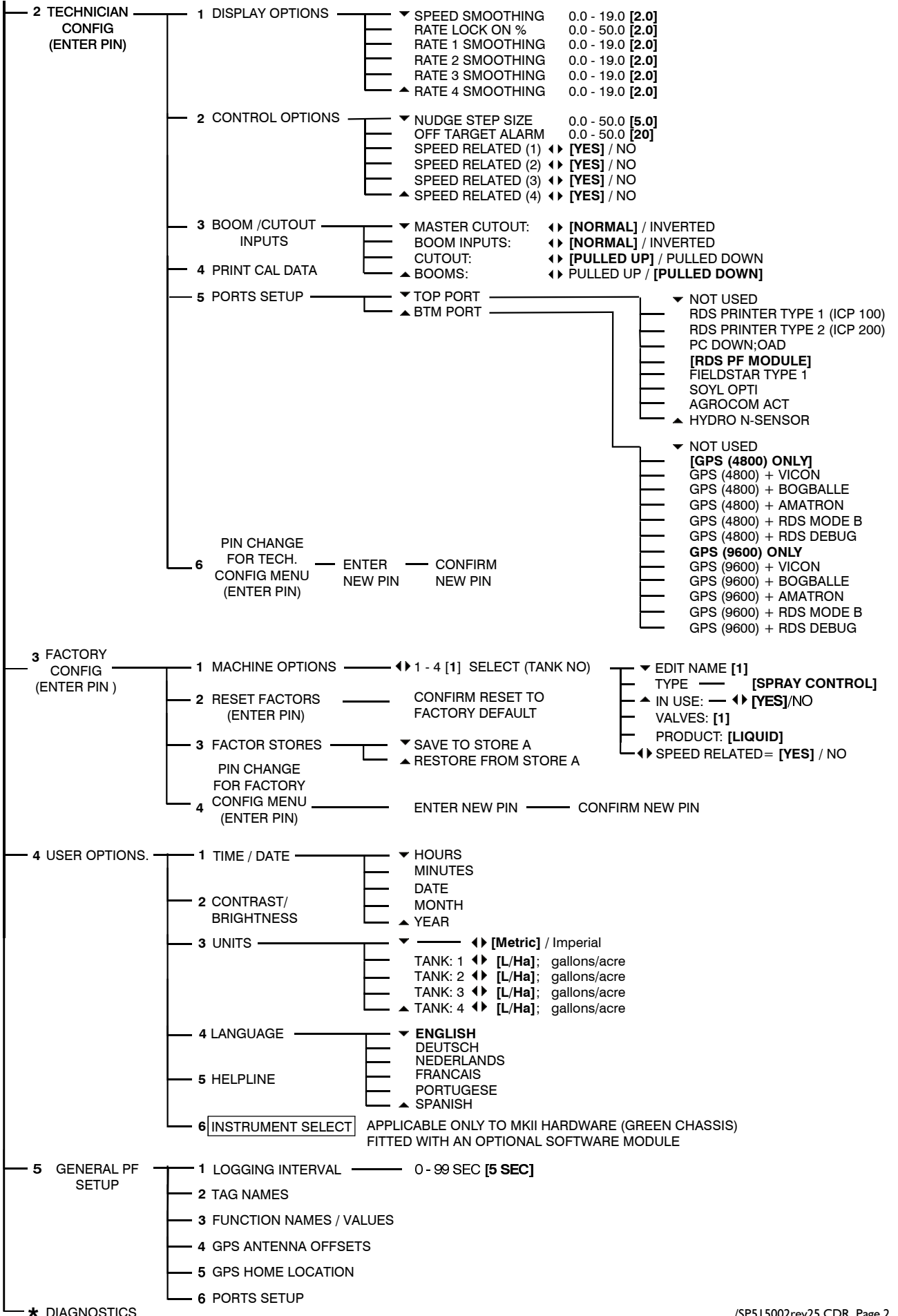

2 Sensor Configuration Menu

Calibrate the Forward Speed Sensor and Flow / Pressure Sensor before commencing liquid calibration.

2.1 Forward Speed Sensor



The Speed Sensor Factor ("SSF") is the distance travelled forward in the time between two pulses from the forward speed sensor. This could be calculated based on the nominal tyre diameter or rolling distance and then entered manually, however this does not take into account wheel slip, compaction, or tyre deformation under practical operating conditions. The best method is to do an "Auto Cal".

2.1.1 Select Wheel Size (Wheel sensor fitted) / Radar Sensor

If the sprayer has a standard wheel sensor and magnets installed, you can programme the instrument with two speed sensor factors for flotation tyres and for row crop wheels. Remember to select the appropriate factor after changing wheels.



- 1 Press  to select the "SPEED FACTOR" screen (fig. 3).
- 2 Move the arrow cursor to select the factor appropriate for flotation tyre or row crop wheel size (or radar sensor if fitted), and press  to confirm.

Figure 3
Selecting the wheel size
/Radar Sensor



2.1.2 "Auto Cal"

The "Auto Cal" procedure is the same for a wheel sensor or a Radar Sensor.

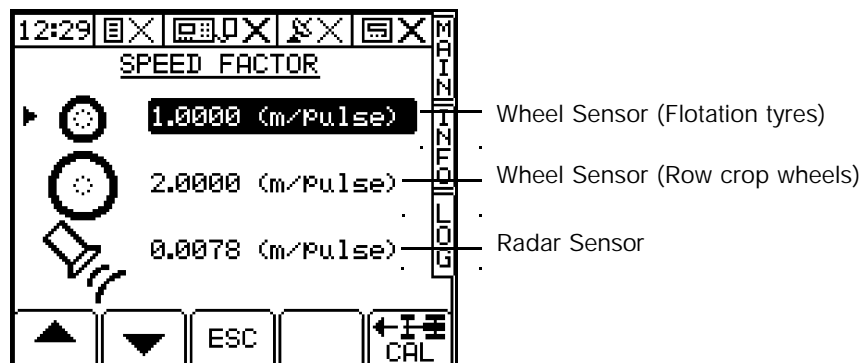
Mark a set distance of 100 metres (or 100 yards depending on the units set on the instrument) by suitable means. The surface should be representative of the average field conditions (i.e. not a paved surface). Position the vehicle with the first marker level with a suitable reference point on the vehicle.

With the appropriate setting highlighted on the "SPEED FACTOR" page, press ENTER, then select "Auto Cal". Press  and then follow the screen instructions.

Stop the vehicle when the second marker lies up with the pre-determined reference point on the vehicle and press  to end the "Auto Cal" procedure. The Speed Sensor Factor is automatically re-calculated and stored in memory.

NOTE: If you overrun the marker, do not simply reverse - repeat the "Auto Cal" procedure from the beginning.

2.1.3 Manual Calibration

If a two-magnet wheel sensor is fitted, drive in field conditions for exactly 10 turns of the sensed wheel.

If a propshaft sensor is fitted, drive in field conditions for exactly 20 turns of the propshaft.

In either case calculate the factor = $\frac{\text{Distance travelled}}{10}$ and enter the value as follows;

With the appropriate sensor highlighted on the "SPEED FACTOR" page, press 

Key-in the new factor and press  to confirm the change.

If a an RDS Radar sensor is fitted (at the correct angle of $37 \pm 1^\circ$),

- 1 Accept the default factor of 0.0078 metres/pulse.
- 2 Set the implement full width to 100m.

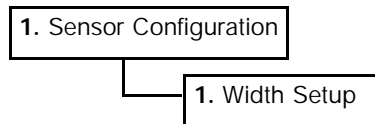

- 3 Select the "INFO" screen to display area accumulation and drive over a 100 metre measured distance. This must be a rolling 100 metres, not a start-stop 100 metres.

If the TGSS factor is correct, the AREA display will show 1.000 hectares. If not then adjust the factor based on the following calculation,

$$\text{New factor} = \text{existing factor} \times \text{displayed area (ha)}$$

- 4 Go back to the "SPEED FACTOR" screen and enter the new factor (see above). Don't forget to reset the implement width to normal.

2.2 Boom Configuration

Select the "Width Setup" screen.

Figure 4a
Setting the number of boom sections

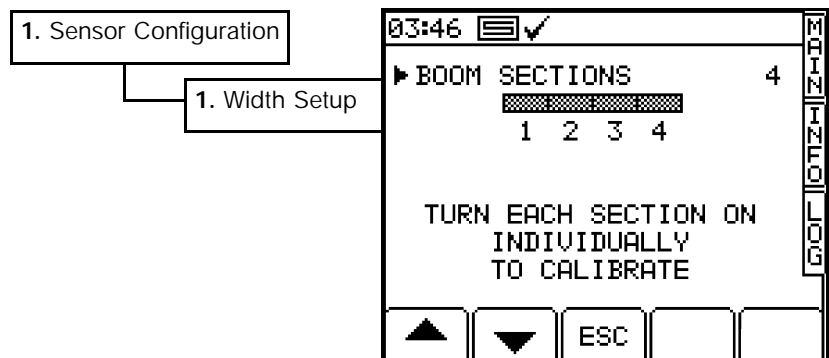

2.2.1 Set number of Boom Sections

Range: 0 - 9 Default: 4

With the screen cursor opposite "BOOM SECTIONS", enter the number of sections from 0 to 9 and press the ENTER button. When a boom section is switched on, the boom section block is filled in.

If boom sections are set to zero, then the whole boom is seen as one unit. The boom section inputs are ignored and the full spraying width is programmed.

Figure 4b
Setting zero boom sections

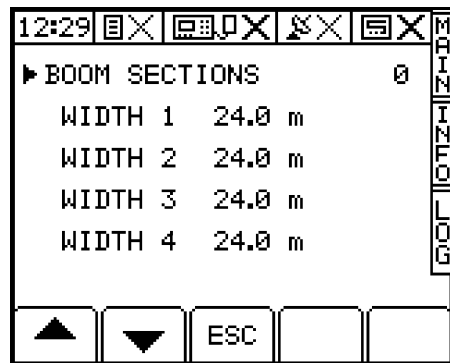

If boom sections are set between 1 and 9, then only one boom configuration can be accommodated, which applies to all channels.

2.2.2 Set No. of Nozzles per section and Nozzle Spacing

This can also be set from the "Nozzle Wizard" screen page.

Switch on each section in turn and programme the number of nozzles and nozzle spacing for that section.

Figure 5
Setting number of nozzles per section and nozzle spacing

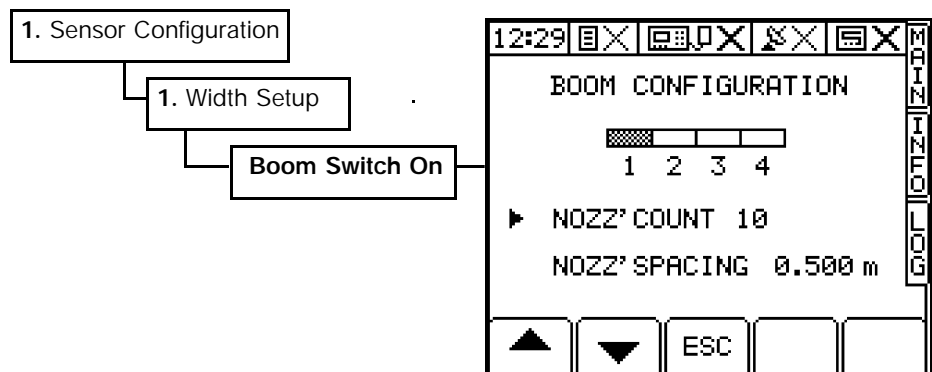

2.3 Flow / Pressure Sensor Setup

The sprayer control system can be installed with either a flow sensor, a pressure sensor, or both to enable either flow-based regulation or pressure-based regulation. **If the installation includes both a pressure sensor and a flow sensor you can re-configure the system at any time from the SETUP page for either type of regulation (section 2.3.11).**

In either case the one sensor is set for regulation and the second sensor is set either to provide information only (flow rate or pressure display), or can be disabled.

Do the Flow / Pressure Sensor Setup before doing the liquid calibration.

Configure for Flow-based Regulation

Figure 6
Flow Sensor Setup

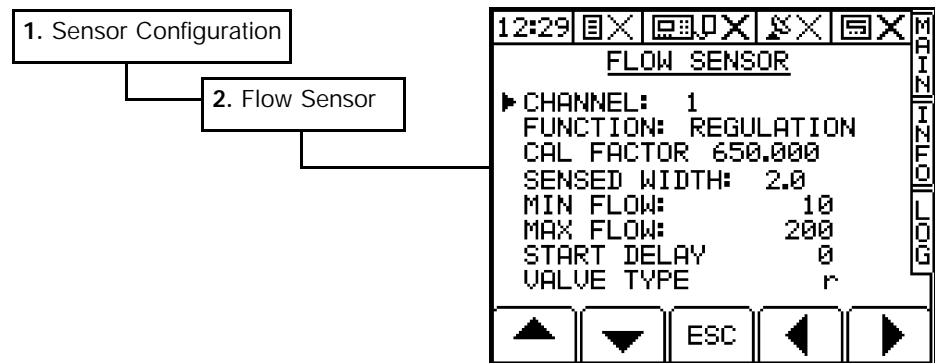

2.3.1 Channel

Channel 1 is the default for single sprayer operation. Additional channels are enabled from the "MACHINE OPTIONS" menu. If you select any channel that has not been enabled in this way you will receive the screen message "NO FLOW INPUT".

Default: Channel 1

2.3.2 Function

Select "REGULATION" for flow-based regulation. Select "NOT USED" if the system is being configured for pressure-based regulation (or "INFO ONLY" if you also want Flow Rate displayed when the system is configured for pressure-based regulation).

NOTE: You can configure any one of the 4 channels as a TANK-FILL Sensor (see section 2.5 for setup).

2.3.3 Sensed Width

Programme the total width of the boom section(s) to which liquid is delivered via the flow sensor. This is normally the full boom width but in some installations, for practical reasons, it may be a single boom section.

Default: 2.0 metres

2.3.4 Flow sensor Cal factor

Initially set the factor (pulses per litre or pulses per gallon) as given below, according to the size of turbine installed.

Turbine size	pulses/litre	pulses/Imperial gallon	pulses/US gallon
1/2"	3 700	-	-
3/4"	1 786	8 119	6 760
1"	650.0	2955	2 460
1-1/2"	1 650	7 491	6 245
2"	1 000	4 546	3 785

These values will be sufficient until you do a liquid calibration by means of a jug test.

NOTE: The Cal Factor will be automatically re-calculated and stored in memory after doing a flow calibration or nozzle calibration routine. It can otherwise be changed manually following "fine tuning" of the nozzle rate.

Default setting: 650 pulses/litre for a 1" turbine

2.3.5 Minimum flow and Maximum flow

Set the values according to the size of turbine fitted.

Turbine size	Min. flow (l / min)	Max. flow (l / min)
1/2"	3	30
3/4"	3	30
1"	10	1 00
1-1/4"	10	1 00
1-1/2"	35	3 50
2"	72	1 00

These values set the threshold for the "FLOW LOW" and "FLOW HIGH" alarms during operation. Minimum and maximum flow can also be set from the "ALARMS SETUP" screen. Set the maximum and minimum flow for the sensor in use.

Default: Min. flow = 10 l/min Max. flow = 200 l/min

2.3.6 Start Delay

When the whole boom or any boom section is switched on, there may be a rush of air or liquid as the boom line fills up which is not true flow out to ground. Flow accumulation will be ignored for this delay time (programmable from 0 - 20 seconds) after the boom is switched on. The flow should stop immediately the boom is switched off.

Default = 0 sec

2.3.7 Valve Type

(Flow-based sprayers only)

If each boom section valve when closed, simply shuts off the flow (e.g. solenoid valves), set to "n" for a non-recirculating system.

If each boom section valve when closed, diverts the flow back to tank (e.g. ARAG, Spray Systems valves), set to "r" for a re-circulating 'balanced return' system.

Default: "r"

Configure for Pressure-based Regulation

Figure 7
Pressure Sensor Setup

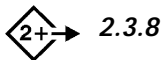
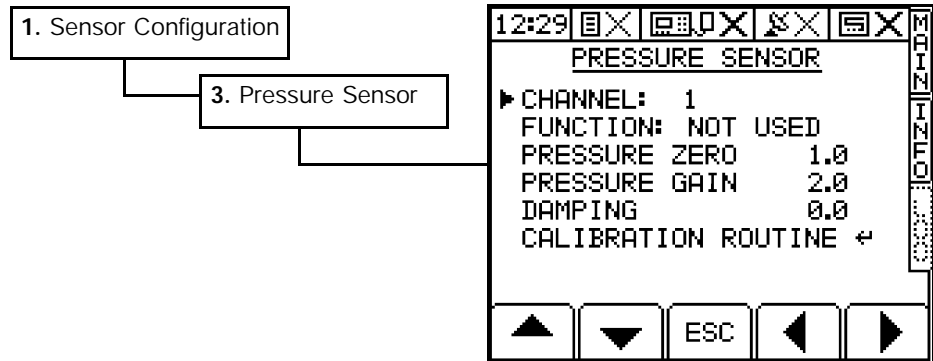

2.3.8 Channel

Channel 1 is the default for single sprayer operation. Additional channels are enabled from the "MACHINE OPTIONS" menu. If you select any channel that has not been enabled in this way you will receive the screen message "NO PRESSURE INPUT".

Default: Channel 1

2.3.9 Function

Select "REGULATION" for pressure-based regulation.

Select "NOT USED" if the system is being configured for flow-based regulation (or "INFO ONLY" if you also want pressure displayed when the system is configured for flow-based regulation).

2.3.10 Calibrate Pressure Sensor

Figure 8a and 8b
Calibrating the Pressure Sensor

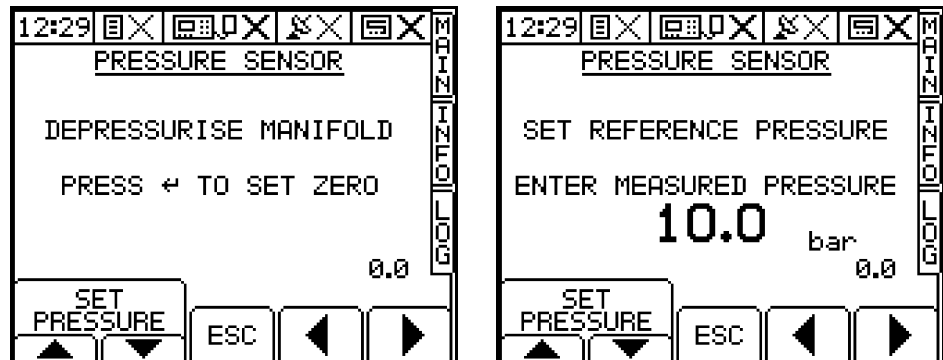

- 1 Select "CALIBRATION ROUTINE" (fig. 7) and press
- 2 Depressurize the manifold and press to set "PRESSURE ZERO" (fig. 8a).
- 3 Start the sprayer and set the reference pressure (the typical working pressure) using the keys (fig. 8b).
- 4 Key-in the pressure indicated on the sprayer pressure gauge and press .

The "PRESSURE GAIN" is then set and is displayed on the "PRESSURE SENSOR" screen (fig. 7). The pressure sensor is now calibrated ready for nozzle calibration.

2.3.11 Changing Regulation Mode

On systems installed with both a flow sensor and a pressure sensor, you can very easily re-configure the system to enable either flow-based or pressure-based regulation.

On a flow-based system, high application rates (e.g. liquid fertiliser application) would require a large sized flow sensor to be installed. However this turbine may not be as accurate at lower application rates required for chemical applications. In this case it may be preferable to install a smaller flow sensor using flow-based regulation for lower application rates, and re-configure the system to use the pressure sensor for pressure-based regulation of high application rates.



- 1 From the SETUP screen, press the  button. (This only appears on the SETUP screen when both sensors are enabled).

Figure 8c
Switching between flow-based and pressure-based regulation



- 2 Select "**Pressure**" or "**Flow**" using the up / down arrow keys and press  to confirm.

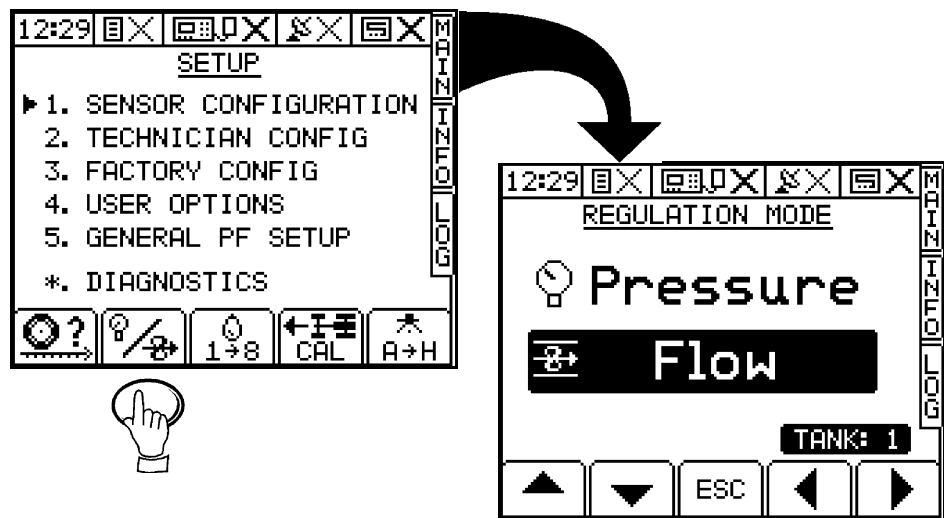

If you have more than one "tank" in use, then select the tank number using the left / right arrow keys before selecting "**Pressure**" or "**Flow**". Tank 1 is the default channel.

2.3.12 Damping

The damping factor enables fluctuations in the pressure readings to be smoothed out. By default the damping factor is zero.

2.4 Configuring the Control Valve

Figure 9
Configuring the Control Valve

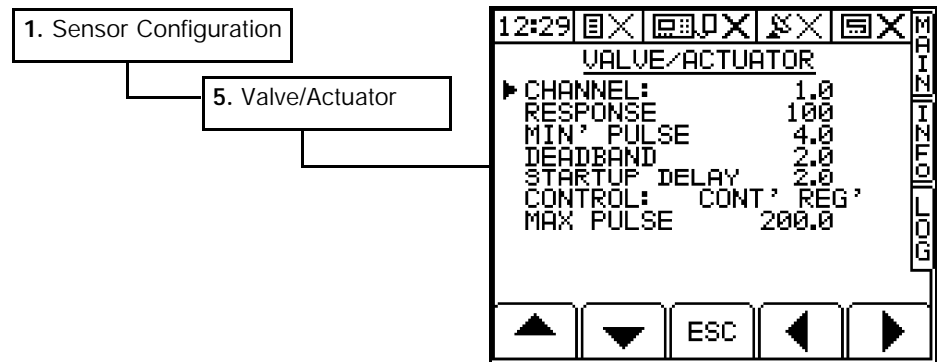

2.4.1 Channel

Channel 1 is the default for single sprayer operation. Additional channels are enabled from the "MACHINE OPTIONS" menu.

Default: Channel 1

2.4.2 Response

The Response function sets the frequency at which the system adjusts the control valve when reacting to a change in forward speed. A lower setting results in a slower response, and increases the time taken for the application rate to match the target rate. A higher setting results in a faster response. If the application rate is unstable and varies about the target rate, then the response setting may be too high.

Default: 100 *Range:* 0 - 9999

2.4.3 Minimum Pulse

This sets the minimum pulse length (milliseconds x 4) driving the flow control valve. The pulses becomes shorter as the application rate nears the target rate. A lower setting gives shorter pulses - too short and the flow rate may not change sufficiently. If the pulse is too long, the system may be unstable about the target rate.

Default: 4.0 (16 ms) *Range:* 0 - 9999

2.4.4 Deadband

The Deadband function sets the range over which the flow rate will vary about the target rate before the control valve will respond. A lower value will make the control respond to a smaller variation in flow and vice versa. If the value is too low the system may be unstable about the target rate.

Default: 2.0 *Range:* 0 - 99.9

2.4.5 Startup Delay

If a spray boom is empty of liquid, the flow into it is rapid until it pressurises. The flow rate then reduces to the correct flow rate. Consequently the system takes some time to stabilise at the target rate. The instrument must be stopped from reacting to the initial flow surge.

Set the delay time to equal the time it takes for the sprayer system to reach normal working pressure. When the whole boom or individual section is switched on, the control valve will not operate for this time period.

Default: 2.0 seconds *Range:* 0 - 99.5 seconds

2.4.6 Control

"WORK REG" - Auto-regulation is only enabled when the boom is switched on.

The power supply to the control valve is switched off when switching off the boom. Therefore, when the sprayer is switched on at the beginning of the next bout, the control valve will be in the correct position enabling a faster return to the target rate.

"CONT' REG" - Auto-regulation is always enabled.

The control valve remains powered when the sprayer is switched off and will therefore close in response.

Default:: "CONT' REG"

2.4.7 Maximum Pulse

This sets the maximum pulse length (milliseconds x 4) driving the flow control valve. Do not change this value from the default of 200.0 (800 ms).

2.5 Configure a Tank-filling Sensor

Figure 10a
Tank-Filling Sensor Setup

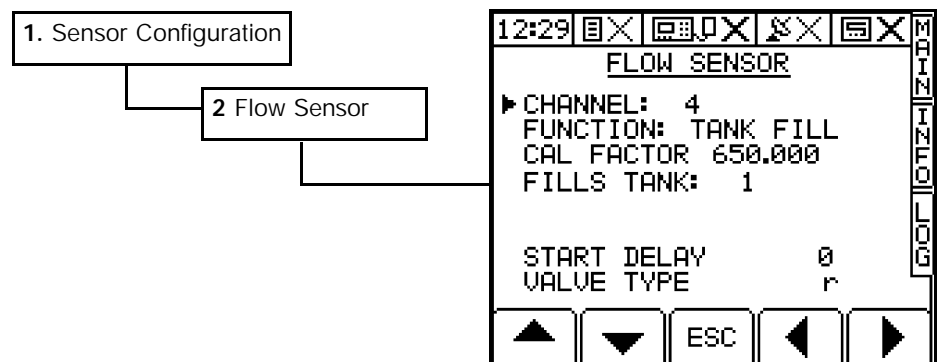

2.5.1 Channel

By default, channel 4 is configured for a tank-filling flow sensor, however, any other of the channels can be configured for tank-filling. Set the FUNCTION to "TANK FILL".

2.5.2 Calibrating the Tank Filling Sensor

Initially set the calibration factor according to the size of turbine installed (2.3.1).

Default: 650 pulses/litre (for a 1" turbine).

Select the "INFO" screen and press  to access the TANK FILL screen.

Set the "NOW" volume to zero.

Fill the empty tank with the known volume (e.g. 2000 litres) of water via the inflow sensor and note the "NOW" volume displayed.

The correct Cal. factor = Initial Factor x $\frac{\text{"NOW" volume}}{\text{Actual volume}}$

e.g. Initial Cal. Factor = 100 and the "NOW" volume reads 1750 litres after filling 2000 litres;

New Cal. Factor = $100 \times (1750/2000) = 87.5$

Go back to the "FLOW SENSOR" screen, key-in the new Cal. Factor and press .

2.6 Alarms Setup

There are a number of alarm conditions that are programmed in to the PS8000. Some of these relate to the nozzle/sprayer performance and are derived from the "Nozzle Wizard". Some are covered in other calibration menus e.g. RPM SETUP. All other alarms are setup from the ALARMS SETUP screen page (fig. 10b)

Figure 10b
Alarms Setup

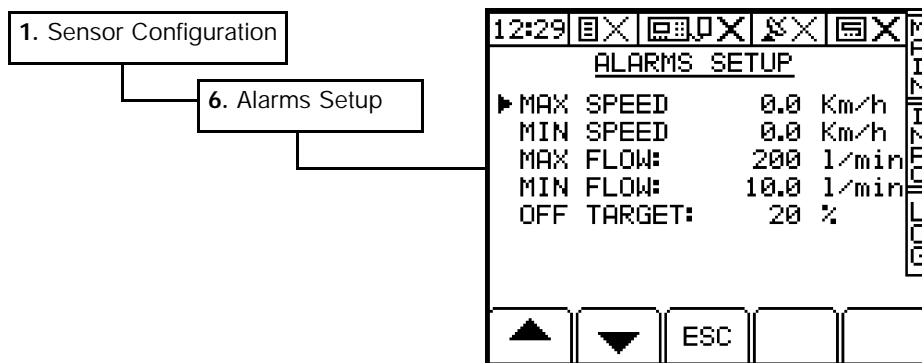

2.6.1 MAX. SPEED and MIN. SPEED

These values set the thresholds for the forward speed alarms. They are automatically set according to the Target Speed in the "Nozzle Wizard", however, you can manually key-in another value via the alpha-numeric keypad.

When another nozzle type is selected in the "Nozzle Wizard", any manually programmed thresholds will be overwritten by the "Nozzle Wizard".

Default = 0 (Alarms Off)

2.6.2 MAX. FLOW and MIN. FLOW (Flow-based regulation only)

These values set the thresholds for the "FLOW HIGH" and "FLOW LOW" alarms during operation. Minimum and maximum flow can also be set from the "FLOW SENSOR" screen. Set the values according to the size of turbine fitted (ref. section 2.3.1).

Default: Min. flow = 10 l/min Max. flow = 200 l/min

2.6.3 OFF TARGET

This sets the threshold at which the instrument will alarm "UNDER APPLICATION" or "OVER APPLICATION" when spraying in automatic control mode. It is set as a percentage either side of the current target rate.

NOTE: This can also be set from the "CONTROL OPTIONS" page.

Default = ± 20%

2.7 Nozzle Setup

Figure 11a

The Nozzle Setup screen otherwise called the "Nozzle Wizard"

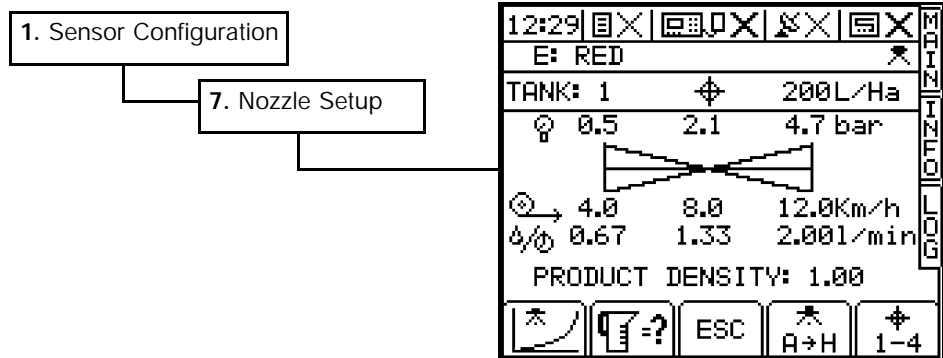

NOTE: The Nozzle Setup screen (the "Nozzle Wizard") is also accessed by pressing the  key directly from the "SETUP" screen.





If you have more than one "tank" enabled, on selecting "Nozzle Setup", the instrument will first prompt you to select the channel to which the nozzle setup will apply (fig. 11b).

Figure 11b

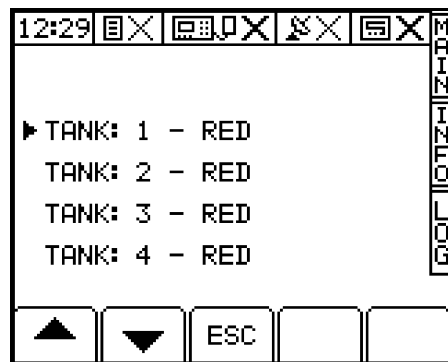
Select channel to which nozzle setup applies



The instrument is pre-programmed with nozzle data for 8 ISO standard nozzle types.

Press  to select a nozzle type. Press repeatedly to cycle through nozzle types A to H. Press  to confirm the nozzle selection.

Press  to start the nozzle calibration procedure (see section 3).

2.7.1 Editing the preset Nozzle type

If the nozzles fitted do not correspond to any of the 8 preset types, then you can easily edit the data for any of the nozzle types A to H.

Press  to select the "NOZZLE EDIT" screen (fig. 12). For all parameters, move the cursor to the appropriate line and enter the new data via the alpha-numeric keypad.

Figure 12

Editing preset nozzle data



2.8 Calibrating an RPM Sensor

Figure 13a
The Alarm Setup screen

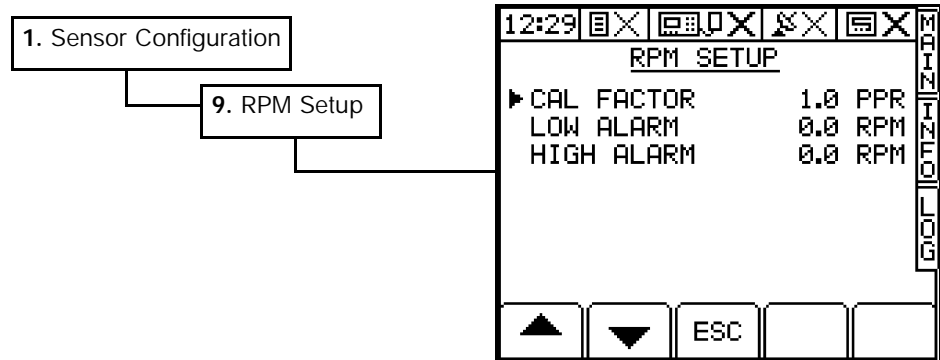

The following calibration procedure applies regardless of the speed output being sensed e.g. Engine RPM, PTO Speed, Shaft Speed, Fan Speed etc, depending on the particular installation.

In all cases, run the sensed component at a known speed. If necessary measure this speed using a hand-held tachometer. Note the speed displayed on the "INFO" screen.

The correct Cal. factor = $\text{Initial Factor} \times \frac{\text{Displayed Speed}}{\text{Actual Speed}}$

Go back to the "RPM SETUP" screen, key-in the new Cal. Factor and press .

Default: 1 pulse per rev (PPR)

2.8.1 LOW / HIGH RPM ALARM

From the RPM SETUP screen, you can also set a minimum and maximum RPM at which an alarm is triggered. Set as necessary.

Default = 0 (Alarms Off)

3 Flow Calibration

Ensure the Flow / Pressure sensors have been properly configured (section 2) before doing a liquid calibration. When spraying denser liquids such as liquid fertilisers, ensure beforehand that you have selected the correct product and have programmed the correct density for that product, from the "PRODUCT CALIBRATION" screen.

3.1 Initial Calibration - using the "Jug Test Wizard"

The following procedure applies for both pressure-based and flow-based regulation. Carry out initial calibration using clean water.



- 1 Set the simulation speed to match the desired speed during spraying, and set the target rate to equal the desired application rate. Target speed can be set from the "Nozzle Wizard" or from the main screen.
- 2 Select the most suitable nozzles from the nozzle wizard (section 2.3 in the operation manual).
- 3 Press  to start the calibration routine. The calibration speed is then displayed (fig. 13b).
- 4 Change the calibration speed if necessary, from that displayed and press  to accept. The "CAL TEST" screen is then displayed. It flashes "CAL" to indicate that speed is being simulated, and gives the message "TURN ON NOW".
- 5 Switch the sprayer on with the jug under the appropriate nozzle. When a boom section is switched on, the "CAL TEST" screen then displays pressure (fig 13c).

Figure 13b and 13c
Nozzle calibration routine



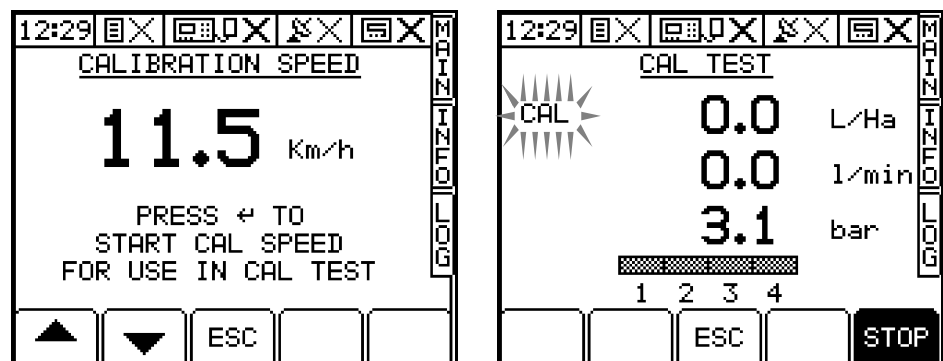

- 6 Press the STOP key to end the metering period.
- 7 Enter the test time (default = 60 sec) and press .
- 8 Enter the test volume (or averaged test volume) and press .

Figure 14
Enter jug test measurements



The instrument then calculates and displays the new calibration factors (fig. 15). Since you can have both a flow sensor and pressure sensor enabled (one sensor for regulation and one for feedback - "INFO ONLY") you will see both:-

- NOZZLE FLOW RATE in litres/min/nozzle ("REF FLOW" on the nozzle data page) for pressure-based regulation.
- FLOW SENSOR CALIBRATION FACTOR in pulses per litre for flow-based regulation.

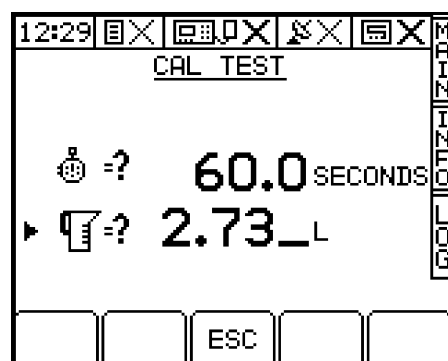
Figure 15
Flow calibration factors

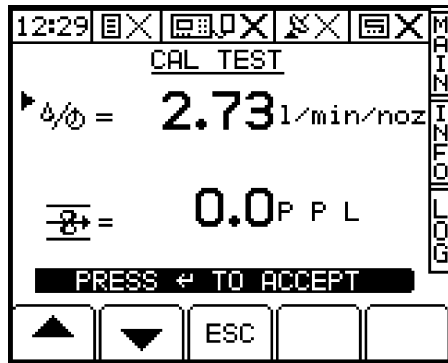

NOTE: It is advisable to repeat the jug test for several nozzles across the boom and enter the average of the individual test volumes.

- 9 Press to accept the nozzle flow rate, (or first enter a revised figure e.g. the averaged flow rate over a number of jug tests).
- 10 Press to accept the flow sensor calibration factor (or first enter a revised figure).

If you don't want to accept the calculated result, press ESC to go back through the previous screens.

NOTE: Performing the jug test changes the previous nozzle flow rate ("REF FLOW") figure stored in the "Nozzle Wizard", and will also correct the calibration factor for the flow turbine.

The jug test is not the most accurate method of calibration particularly for the flow turbine on flow-regulated systems, as the test volume is relatively small. It is therefore recommended to subsequently perform a full-tank calibration, spraying a tankfull out in the field.

3.2 Full-Tank Calibration

The calibration figure should be subsequently "fine-tuned" after spraying out a full tank in the field. **Be certain of the the volume sprayed out since the sprayer sight gauge may not be accurate enough for calibration purposes.** The liquid calibration should be checked and adjusted regularly over the season to compensate for factors including nozzle wear.









- 1 From the SETUP page press  to select the "PRODUCT SELECTION" page.
- 2 If you are spraying clean water or chemicals, check that the product (default name = "Spray A") has density set to 1.00. If spraying liquid fertiliser, check the product and density is selected and programmed.
- 3 Select the "INFO" screen and reset the "PART TOTAL" to zero.
- 4 Spray out the whole tank then select the "INFO" screen and note the "PART TOTAL" clocked.
- 5 Compare this with the known volume sprayed out. If there is a difference between the two figures, then correct the error via the CAL NUDGE screen as follows:
- 6 Go back to the "PRODUCT SELECTION" page, select "PRODUCT CALIBRATION" and press  (fig. 16).
- 7 Select "CAL NUDGE" and press  (fig. 16).

Figure 16
Nudging the calibration factors

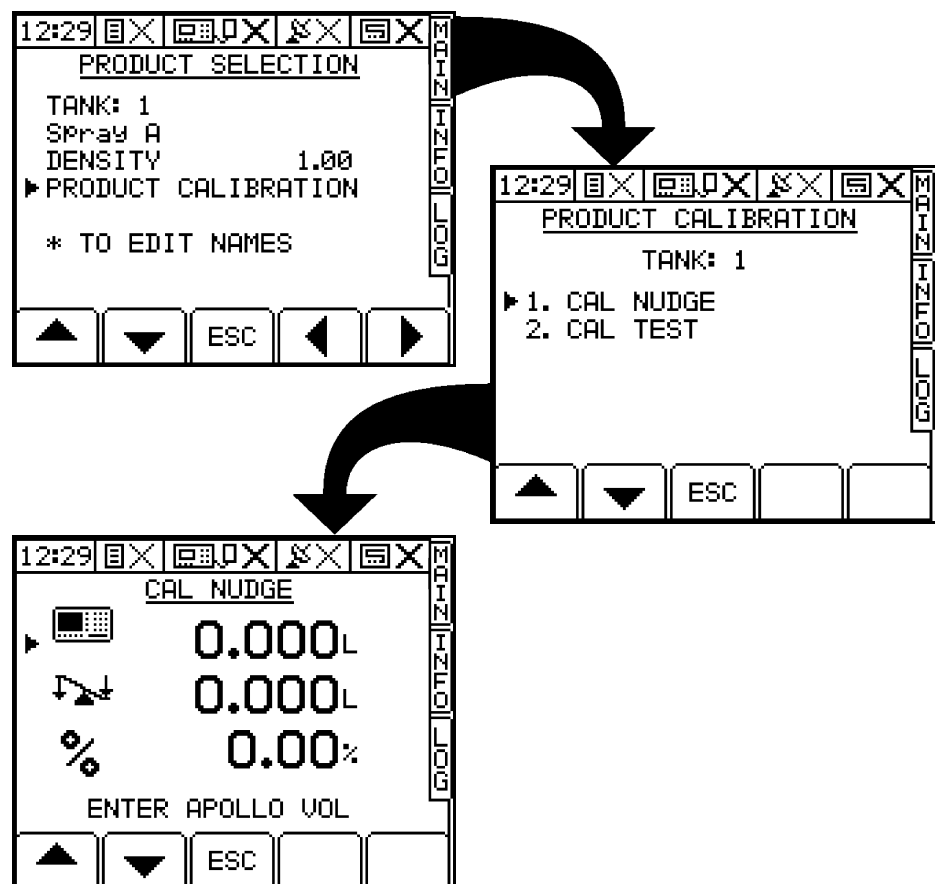

- 8 Enter the instrument total  and press , then the known volume  sprayed out and press . Finally, press  again to confirm the nudge.

The calibration factors are then adjusted accordingly.

4 Technician Configuration Menu

The operator is unlikely to need access in normal use. Access to this menu can be restricted by changing the PIN number from within the menu.

Enter the default PIN number 1234 to access the menu.

4.1 Display Options

Figure 17
"Display Options" page

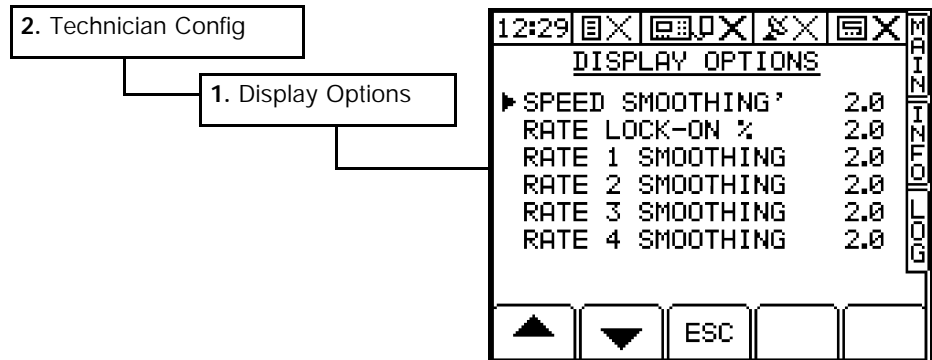

4.1.1 Speed Smoothing Factor

The Forward Speed display is electronically damped. If the readouts are constantly changing by small increments, you can increase the damping time to give a steadier readout.

Adjustable from 0 to 19 seconds. Default = 2 seconds

4.1.2 Rate Lock-On

"RATE LOCK-ON" sets the % by which the application rate fluctuates either side of a nominal application rate *before* the instrument display changes.

For example, if your actual application rate fluctuates in normal operation from 97 to 103 l/ha for a target application rate of 100 l/ha, you may decide that it is acceptable for the instrument to display a steady readout of 100 l/ha between those limits i.e. $\pm 3\%$. In this case the rate lock-on figure should be set to 3.0.

Adjustable from 0 to 50% Default = 2%

4.1.3 Rate Smoothing

The Application rate display is electronically damped. If the readouts are constantly changing by small increments, you can increase the damping time to give a steadier readout.



If you have more than one "tank" in use, then you can set rate smoothing for each tank.

Adjustable from 0 to 19 seconds. Default = 2 seconds

4.2 Control Options

Figure 18
"Control Options" page

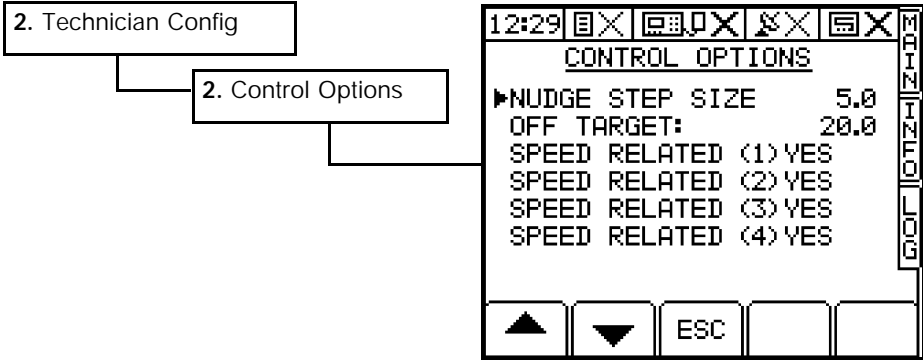

4.2.1 Nudge Step Size

The Nudge Step Size sets the % increase / decrease made when you adjust from the target rate in AUTO mode.

Adjustable from 0 to 50% Default = 5%

4.2.2 Off Target Alarm

This sets the threshold at which the instrument will alarm "UNDER APPLICATION" or "OVER APPLICATION" when spraying in automatic control mode. It is set as a percentage either side of the current target rate.

NOTE: This can also be set from the "ALARMS SETUP" page.

Adjustable from 0 to 50% Default = 20%



4.2.3 SPEED RELATED: Options

Default = "YES" - This enables the flow rate to be automatically adjusted according to the forward speed, to match the target application rate (l/ha) in AUTO mode.

"NO" - The target application rate (l/ha) is replaced by the target flow rate (l/min). The control system will then seek to achieve this target rate.

NOTE: This is also configurable from the "MACHINE OPTIONS" page.

4.3 Boom Cutouts / Inputs

Figure 19
"Boom/Cutouts Inputs" page

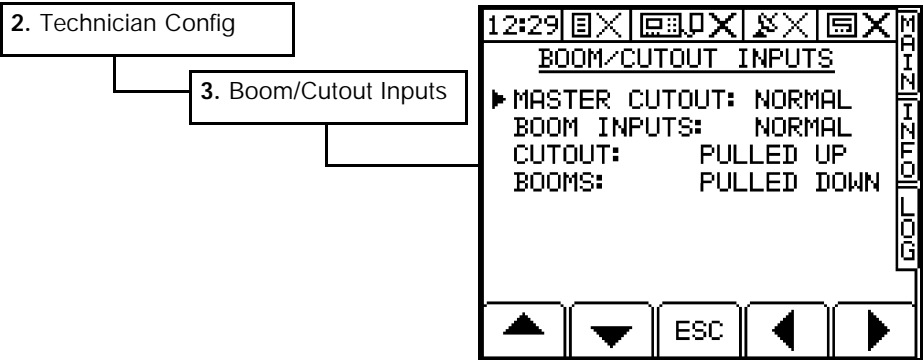

Master Cutout

NORMAL: The sprayer is ON when the cutout input is NOT recognised.
INVERTED: The sprayer is ON when the cutout input is recognised.

Boom Inputs

NORMAL: The boom section is ON when the boom section input is recognised.
INVERTED: The boom section is OFF when the boom section input is recognised.

Cutout

PULLED UP; Master cutout input is recognised when it closes to 0V.
PULLED DOWN: Master cutout input is recognised when it closes to +V.

Booms

PULLED UP; Boom section input is recognised when it closes to 0V.
PULLED DOWN: Boom section input is recognised when it closes to +V.

Default settings shown in bold. Change as required using the arrow keys.

4.4 Print Calibration Data

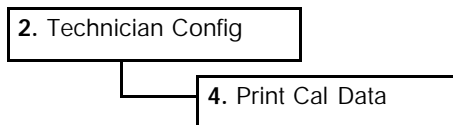

It is always a good idea to keep a record of calibration data either in the back of the manual, or as a printout. Connect the printer to the upper serial port. Ensure first that the port has been configured for a printer (section 4.5.1).

Selecting the "PRINT CAL DATA" menu function immediately sends the data to the serial port. The message "**Printer Busy**" is displayed while data transfer is occurring.

If the bar on the screen stops filling up part way, the instrument cannot communicate with the printer. Check the connections.

4.5 Ports Setup - Top Port (Apollo only)

4.5.1 Enabling Printer Output

Set the top port to "RDS PRINTER TYPE I" for an RDS ICP 100 printer, or "RDS PRINTER TYPE II" for an RDS ICP 200 printer. The data protocol is:

	Printer Type I	Printer Type II
Baud rate:	4 800	4 800
Data Bits:	7	8
Stop Bits:	2	1
Parity:	None	None
Handshake:	Hardware	Hardware

These settings cannot be changed. If you are connecting a different printer, it must conform to either of these protocols.

4.5.2 **Connecting an RDS Data Module**

Set the top port to "RDS PF MODULE".

4.5.3 **Receiving Variable Rate Treatment instructions from other control systems**

The *Pro-Series 8000* can act on variable-rate treatment instructions received from another controller. Presently it can receive instructions from FIELDSTAR (TYPE 1), SOYL OPTI, AGROCOM ACT and HYDRO-N SENSOR instruments.

Set the top port as appropriate.

4.5.4 **Direct Transfer of Field Data to a PC**

If you are connecting a PC using an RDS Download Lead in order to transfer ordinary field data and job memos, set the top port to "PC DOWNLOAD".

4.6 **Ports Setup - Bottom Port (Apollo only)**

4.6.1 **Enabling GPS Input**

If the *Pro-Series 8000* is installed with an RDS control system, then set the bottom port to either "GPS (4800) ONLY" or "GPS (9600) ONLY", according to the baud rate that your GPS receiver has been configured.

4.6.2 **Sending Variable Rate Treatment instructions to other control systems**

The *Pro-Series 8000* can also output variable-rate instructions to other control systems other than an RDS control system. Currently it can send instructions to Vicon, Bogballe and Amatron systems.

Set the bottom port to the appropriate baud rate/control system option from the menu:

GPS (4800) + VICON
 GPS (9600) + VICON
 GPS (4800) + BOGBALLE
 GPS (9600) + BOGBALLE
 GPS (4800) + AMATRON
 GPS (9600) + AMATRON

NOTE: Ignore "RDS MODE B" and "RDS DEBUG" options.

4.7 **Change PIN for Technician Menu**

2. Technician Config

6. PIN # Change

You can re-programme your own PIN for this menu. Just follow the screen instructions.

If you forget your personalised PIN, you will need to contact RDS for instructions.

5 Factory Configuration Menu

The operator is unlikely to need access in normal use. Access to this menu can be restricted by changing the PIN number from within the menu.

Enter the default PIN number 1234 to access the menu.

5.1 Machine Options (Apollo only)



The "MACHINE OPTIONS" screen allows you to configure each of up to 4 control channels.

Figure 20
Selecting the "Machine Options"

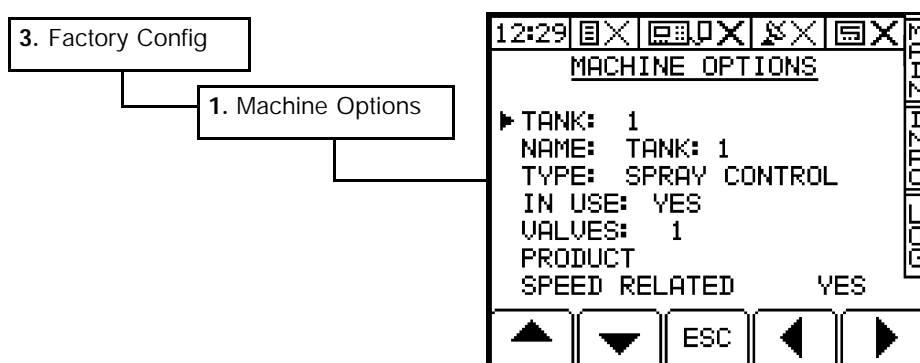

5.1.1 TANK: Enable / Disable "Tanks"

Selects Tank 1 to 4. Using the arrow keys, move to the "IN USE" line and select "YES" or "NO". By default, only Tank 1 is enabled.

5.1.2 TYPE: Type of machine

Preset to "SPRAY CONTROL".

NOTE: If you want to transfer the head unit e.g. over to a spreader or for soil mapping, re-configure from the "INSTRUMENT SELECT" page. You must have the appropriate software module installed in the back of the instrument.

5.1.3 NAME: Edit Tank Name

You can edit the default name ("Tank #"). The maximum length is 20 characters.

5.1.4 SPEED RELATED: Options

Default = "YES" - This enables the flow rate to be automatically adjusted according to the forward speed, to match the target application rate (l/ha) in AUTO mode.

"NO" - The target application rate (l/ha) is replaced by the target flow rate (l/min). The control system will then seek to achieve this target rate.

NOTE: This is also configurable from the "CONTROL OPTIONS" page.

5.2 Total Software Reset

Figure 21
Resetting the calibration factors to the factory default values

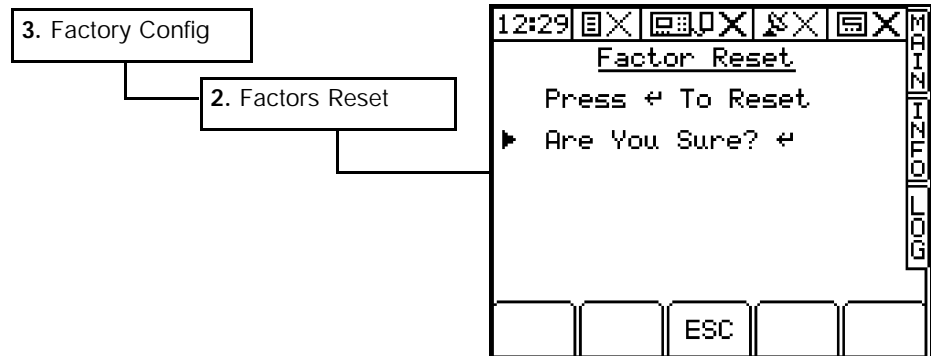

A "FACTOR RESET" should be considered in two instances. Firstly, if the instrument is to be transferred to a different sprayer, it may be easier to re-calibrate the instrument from the factory default settings in a systematic way. Secondly, if you are encountering problems with the instrument during operation but cannot successfully resolve them, a total software reset may help in the troubleshooting procedure.

Follow the screen prompts to reset the instrument to the factory default settings.

NOTE: *All customised factors and other data will be lost. It is recommended you keep a record of the existing calibration data.*

5.3 Backing Up and Restoring Calibration Data

For extra security, calibration data can be manually saved to a separate memory area called "STORE A". This data will NOT be overwritten each time the instrument is switched off, but it WILL be cleared after a Total Software Reset ("RESET FACTORS").

If for example, any calibration data is unwittingly changed without keeping a record of previous settings or data is corrupted, you can restore the calibration data from "STORE A" at any time.

Figure 22
Save / Restore CAL Data

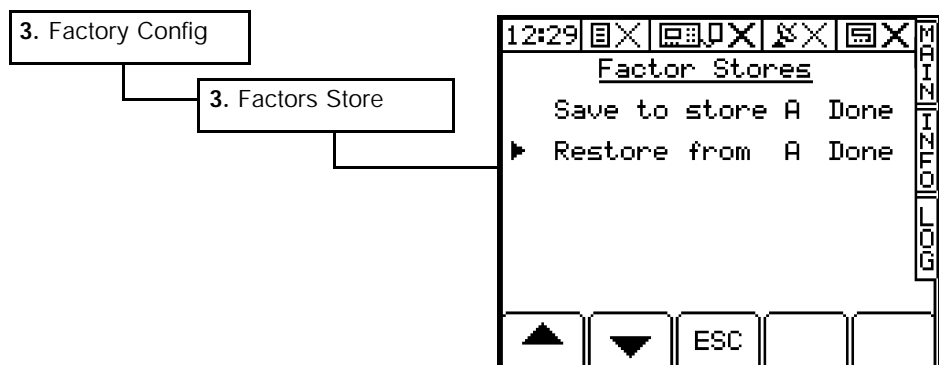

5.4 Change PIN for Factory Configuration Menu

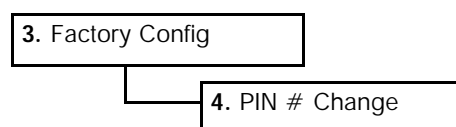

You can re-programme your own PIN for this menu. Just follow the screen instructions. If you forget your personalised PIN, you will need to contact RDS for instructions.

6 User Options

6.1 Set Time and Date

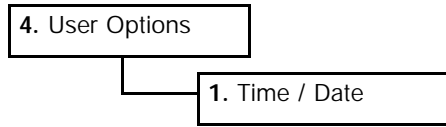

If you need to change the time or date setting, position the cursor against the relevant line, key-in the new value and press .

6.2 Adjust Screen Contrast and Brightness

Figure 23
Adjusting Contrast and Brightness

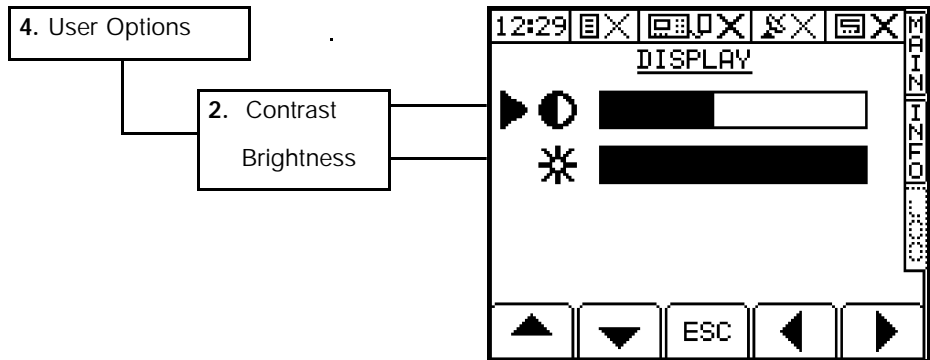

The screen may go darker at very high or very low temperatures. For example, on a very cold morning it may take a short period of time for the display to gain normal contrast as the instrument warms up. This is a normal characteristic of this type of display and does not mean the display is faulty.

If by accident the contrast setting is adjusted so that the screen graphics can no longer be viewed (i.e. completely light or dark), don't panic! - you can navigate directly to the "DISPLAY" screen by pressing and holding the  key for at least 20 seconds. The instrument will bleep at 0.5 second intervals as long as the key is depressed.

You can then adjust the display using the arrow keys.

6.3 Set Units

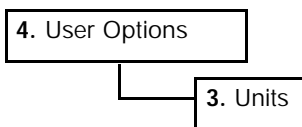



Units are either Metric (litres/hectare) or Imperial (gallons/acre).

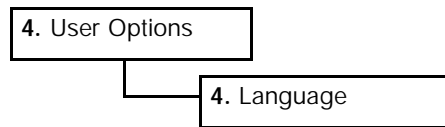

They can be set independently for each tank enabled from the "MACHINE OPTIONS" page.

6.4 Select Language





Select the language using the up / down arrow keys and press .

6.5 Select Control Software (Apollo only)

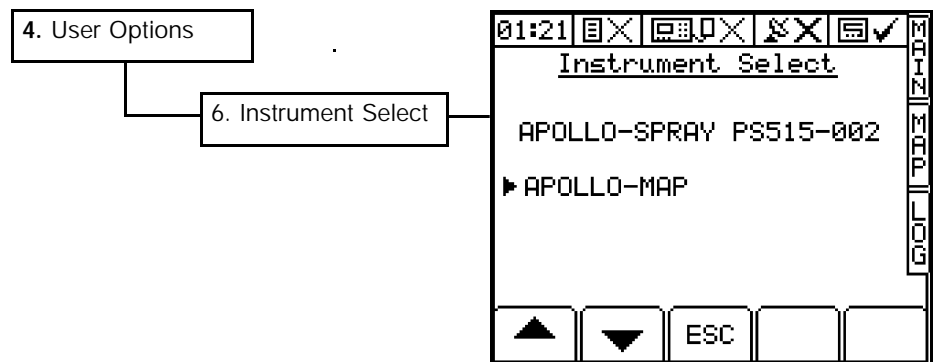
Figure 24
Select Control Software



There are two lines displayed. If the head unit does not have a secondary software module fitted, both lines will be the same and switching between them has no effect.

If a software module is fitted, then simply select between the two software options displayed and press . The instrument will take several seconds to load the control software and then  automatically re-start.

7 General PF Setup (Apollo only)

THE PS8000 must be setup to recognise the Data Module (section 4.5.1) and GPS Input (section 4.6.1).

The "GENERAL PF SETUP" menu is common to all PS8000 control software modules PS515-xxx (Sprayers), PS516-xxx (Belt Spreader), PS805-xxx (Disc Spreader) and PS517.xxx (Route / Soil Mapping), and PS302-xxx (Ceres 8000 Yield Monitor) so some settings may not apply in your current application.

For information on connecting and configuring RDS PF hardware e.g. the Data Card Module, Secondary Software Module, DGPS Receiver, cables etc, and data transfer to your PC, please refer to the "Precision Farming Supplement".

7.1 Set Logging Interval

Figure 25
Select Control Software

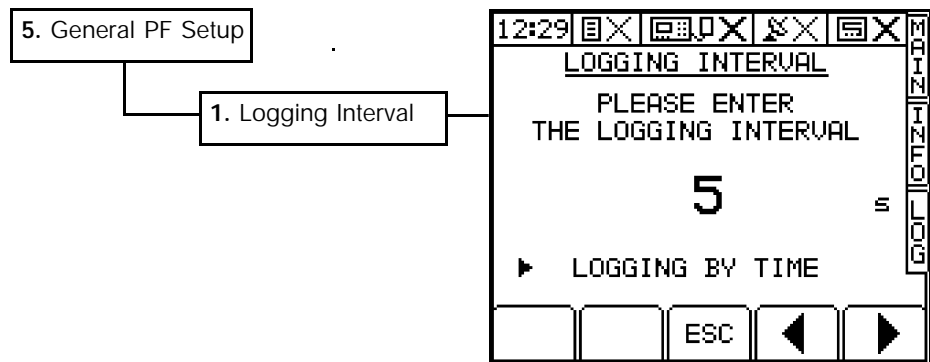

It is recommended that you use the default setting of 5 seconds. This should be adequate for variable-rate treatment and yield mapping.

Decreasing the logging interval may affect the responsiveness of the control system and generate very large log files, therefore reducing the number of jobs that can be accommodated on the PCMCIA card. An exception is when you are boundary mapping (where less data is being generated), you can reduce the logging interval to get better definition of the field boundary.

Simply enter the interval value and press to confirm.

Although the option to select the logging interval by distance is available (using the left / right arrow keys), it no longer recommended you do so.

7.2 Edit Tag Names

Figure 26
Edit Tag Names

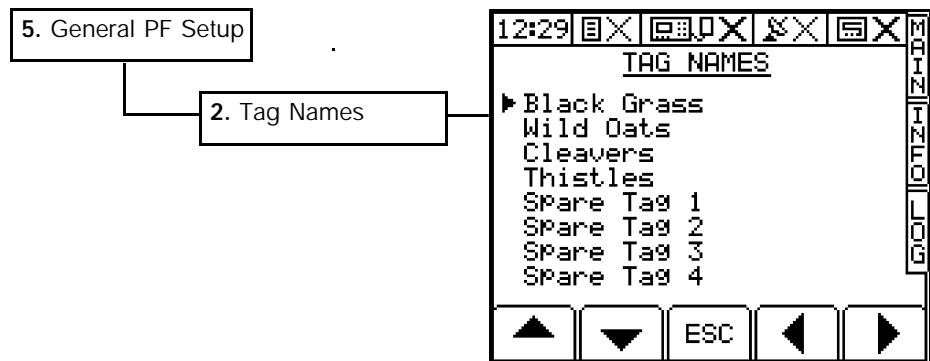

Applies to yield mapping only.

While dynamic logging is in progress the operator can switch on or off any of up to 8 'tags' which effectively place markers on subsequent yield maps to denote particular features such as weed patches etc. Each tag can be named (up to 20 characters) to denote its meaning on the yield map. The first 4 tag names are factory preset as:-

Black Grass
Wild Oats
Cleavers
Thistles

To change a name, first position the menu pointer against a 'Tag number' (fig. 26). Using the RIGHT ARROW key, move the screen cursor across to the tag name and enter the data (up to 20 alpha-numeric characters) via the alpha-numeric keypad.

Press  to confirm the data entry then repeat the procedure as required for further tag names.

7.3 Edit Function Names and Values

Figure 27
Edit default Extended
Function Names and values

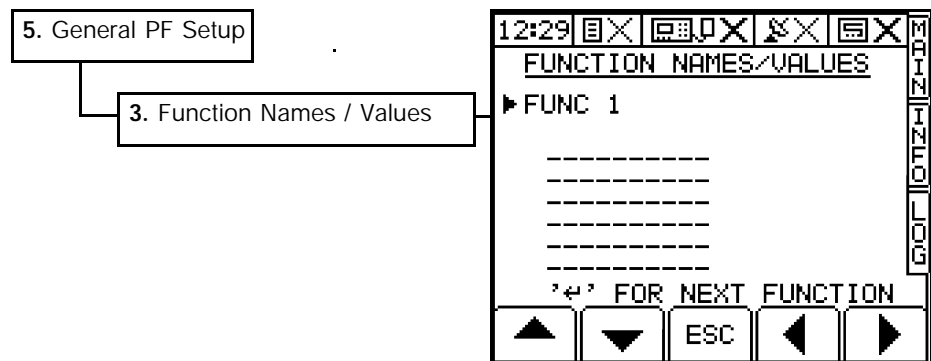

The default settings can be re-programmed for any of the extended data functions (default names = "FUNC 1" - "FUNC 12") e.g. Crop variety, Contractor information etc.

To change a name, first select the function number using the  key (fig. 27). Using the RIGHT ARROW key, move the screen cursor across to the function name and enter the data (up to 20 alpha-numeric characters) via the alpha-numeric keypad.

To enter a value, move the cursor down to the first line and enter the data. You can enter up to 6 lines each of 10 characters.

7.4 Set GPS Antenna Offset

Figure 28
Set GPS Antenna Offset

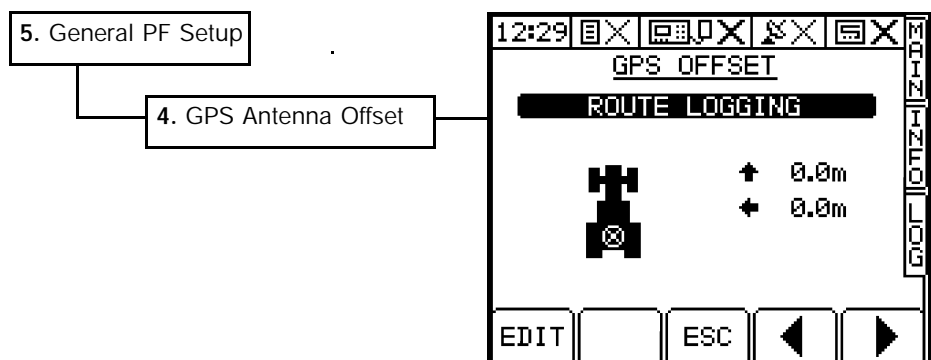

The "Antenna Offset" allows you to compensate for the difference in position between the GPS antenna and the feature being logged, centre of the spray boom/cutter bar/coulter bar, or the centre point of a spreading pattern. For example you might need a 2 metre side offset for boundary mapping from a quad bike. If you are using a front or rear-mounted sprayer/spreader (or both in some cases), you can make front / rear offsets for up to 4 "tanks".

You can have six separate configurations for,

- ROUTE LOGGING
- SOIL SAMPLING
- PLAN CHANNEL 1
- PLAN CHANNEL 2
- PLAN CHANNEL 3
- PLAN CHANNEL 4

(Default for all configurations = no offset).

- 1 Select the configuration that you wish to edit and press the EDIT key (fig. 28).
- 2 Use the arrow keys to offset the antenna position in 0.5 metre increments (fig. 29).

Figure 29
Offsetting the antenna position

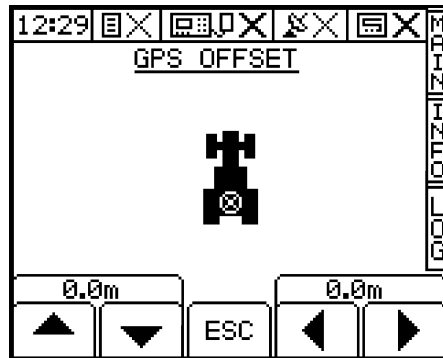

7.5 GPS Home Location

Figure 30
Set GPS Antenna Offset

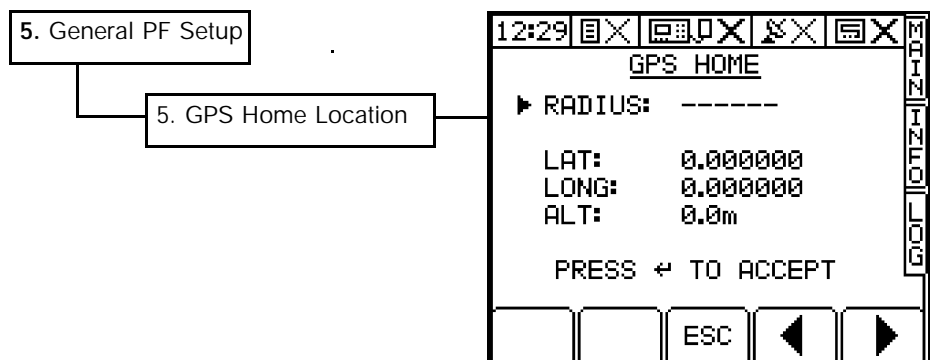

7.5.1 Setting the Home Location and Operating Radius

This page should display your current position from your GPS receiver. Press  to store this position as the "home location" e.g. the farm.

Enter a radius value. Any position received outside the operating radius will be ignored and is assumed to be corrupt data.

7.5.2 ***Moving to another location***

If you subsequently move outside the radius circling the home location, the instrument will automatically reset the "home location" to the current position ONLY IF it receives 10 consecutive, full differential GPS signals.

At any time, you can press the  key to manually set the home location to your current position.

Document History

Issue 1	25/11/99	Original Issue for S/W Ver. PS505-010
Issue 2	13/3/01	Update to S/W Ver. PS515-002 rev.004
Issue 3	23/7/01	Update to S/W ver. PS515-002rev25 (Apollo0 and also covers Delta 34 (S/W PS521-000rev10)