

APOLLO SPRAYER INSTALLATION (SINGLE CHANNEL / SINGLE CONTROL VALVE) FLOW-BASED OR PRESSURE-BASED CONTROL

HEAD UNIT
S/HU/268-5-002

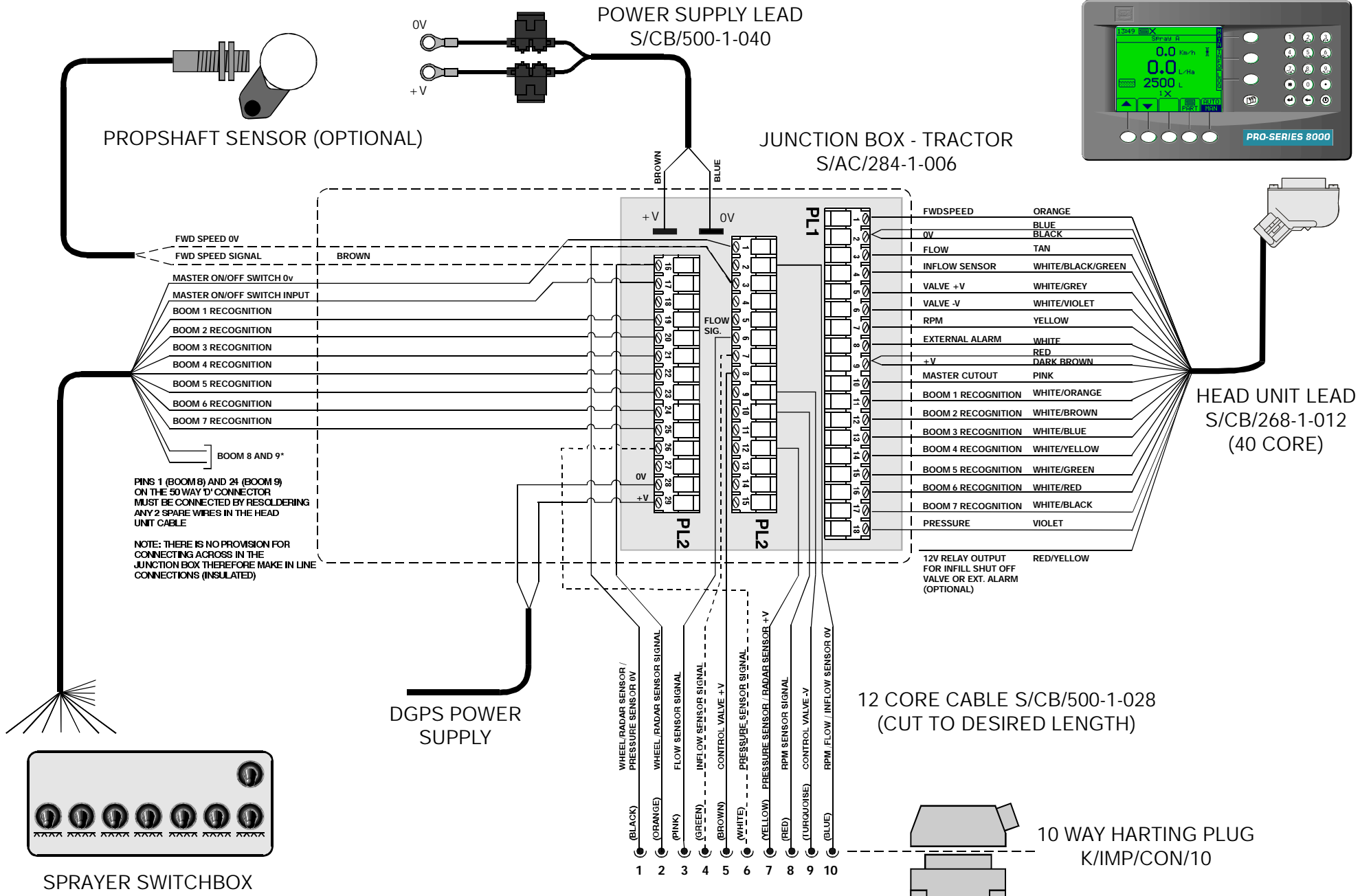

APOLLO SPRAYER INSTALLATION (SINGLE CHANNEL / SINGLE CONTROL VALVE) FLOW-BASED OR PRESSURE-BASED CONTROL

