

Electro-Magnetic Compatibility (EMC)

This product complies with EC Directive 2004/108/EC when installed and used in accordance with the relevant instructions.



Service and Technical Support

PLEASE CONTACT YOUR NEAREST DISTRIBUTOR

If unknown then fax: 44 (0) 1453 733322

© Copyright RDS Technology Ltd 2006

Document number

S/DC/500-10-464: [Issue 1e : 7/4/06](#)

[\UK464-1e.DOC](#)

User Guide

“SPRAYMASTER 200”

Sprayer Monitor / Controller

Installation and Calibration

Software Reference WZ402-002 rev.02

Contents

1.	Installation - Overview	3
1.1	Base Kit	4
1.2	Flow-and/or Pressure-based Plumbing	5
1.3	Terminator	6
1.4	Cutout Switch/ACI	7
2.	Calibration	8
2.1	Boom/Cutout Switch Setup	8
2.1.1	Enable Single Boom Configuration (Standard)	8
2.1.2	Enable Multiple Boom Configuration	8
2.1.3	Select Default Boom	8
2.1.4	Set No. of Nozzles per Section	9
2.1.5	Nozzle Spacing	9
2.2	Select Pressure or Flow-based Regulation	9
2.3	Pressure-based Setup	10
2.3.1	Pressure Sensor Auto Calibration	10
2.3.2	Manually adjust the Pressure Sensor Gain Factor	11
2.3.3	Adjust Nozzle Flow Rate and Reference Pressure	12
2.4	Flow-based Setup	13
2.4.1	Enable / Adjust Flow Sensor Cal Factor	13
2.4.2	Select Default Flow Sensor	13
2.4.3	Set No. of Sensed Nozzles	14
2.4.4	Valve Type	14
2.5	Control Valve Settings	14
2.5.1	Response Factor	14
2.5.2	Minimum Pulse Width	15
2.5.3	Deadband	15
2.5.4	Startup Delay	15
2.6	Speed Sensor Setup	16
2.6.1	'AutoCal'	16
2.6.2	Manually calculating the Factor	16
	Number of Sensor magnets	17
	Example Calculation 1	18
	Example Calculation 2	18
	Manually setting the Factor	18
2.7	Other Settings	19
2.7.1	Set Step % in Automatic Mode	19
2.7.2	Units	19
	Functions summary	20

1. Installation - Overview

Figure 1

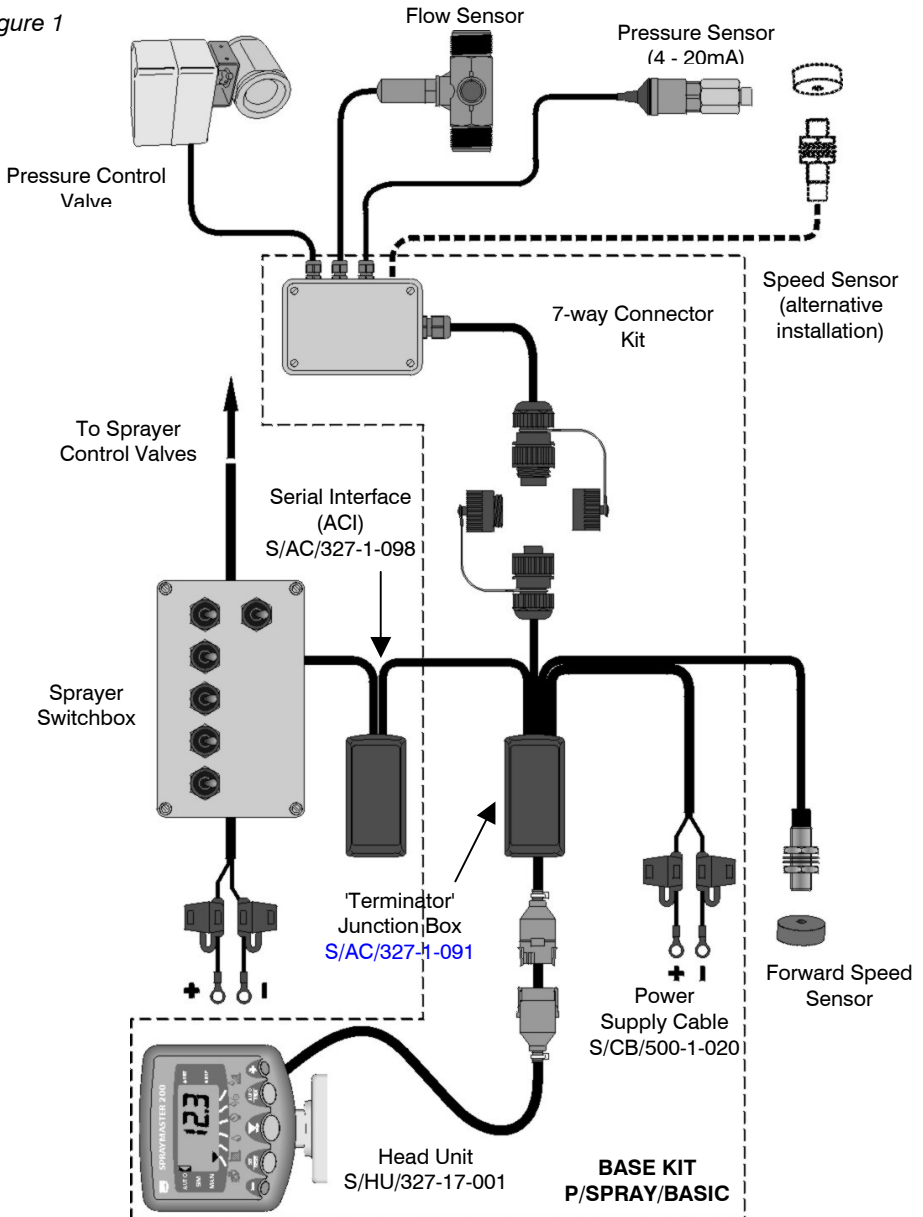

The Spraymaster 200 can be retrofitted to almost any make or model of sprayer - self-propelled, trailed or demountable, and configured for either flow-based or pressure-based regulation. It is therefore, supplied as a modular system comprising a Base Kit, plus individual kits specified as required for the particular installation, e.g.

- **Pressure sensor** (mA output only)
and/or:
- **Flow sensor** (1/2", 3/4", 1", 1-1/4", 1-1/2" or 2" kit)
plus:
- **Forward speed sensor** (range of kits)
- **Control valve** (3/4", 1" or 2" kit)
- **Cutout Switch** (range of kits)
or:
- **Serial ACI Interface** (interfaces with sprayer switchbox)

1.1 Base Kit

The Base Kit comprise the following parts:-

P/SPRAY/BASIC			
Item	Part Number	Description	Qty
1	K/WIZ/MTG/BKT	Head Unit mounting Bracket kit	1
2	K/INSTRUMENT/HC	Power Supply Kit	1
3	K/7WAY/CONN/MK2	Demountable Kit	1
4	K/ACI/WIZARD	ACI Interface	1
5	S/HU/327-17-001	Head Unit	1
6	S/HU/327-1-091	Terminator	1
7	S/DC/500-10-470	Terminator Label	1
#	S/DC/500-10-464	Installation/Calibration Manual	1
#	S/DC/500-10-467	Quick Reference Card	1
#	S/DC/500-10-508	Installation Leaflet	1
#	S/DC/500-10-463	Operation Manual	1

1.2 Flow-and/or Pressure-based Plumbing

Figure 2 illustrates the general plumbing arrangement for the RDS components.

- [1] General installation instructions are included in the individual kits. Please refer to these as required. Any additional instructions specific to a Spraymaster installation are given in section 1.3.

Figure 2

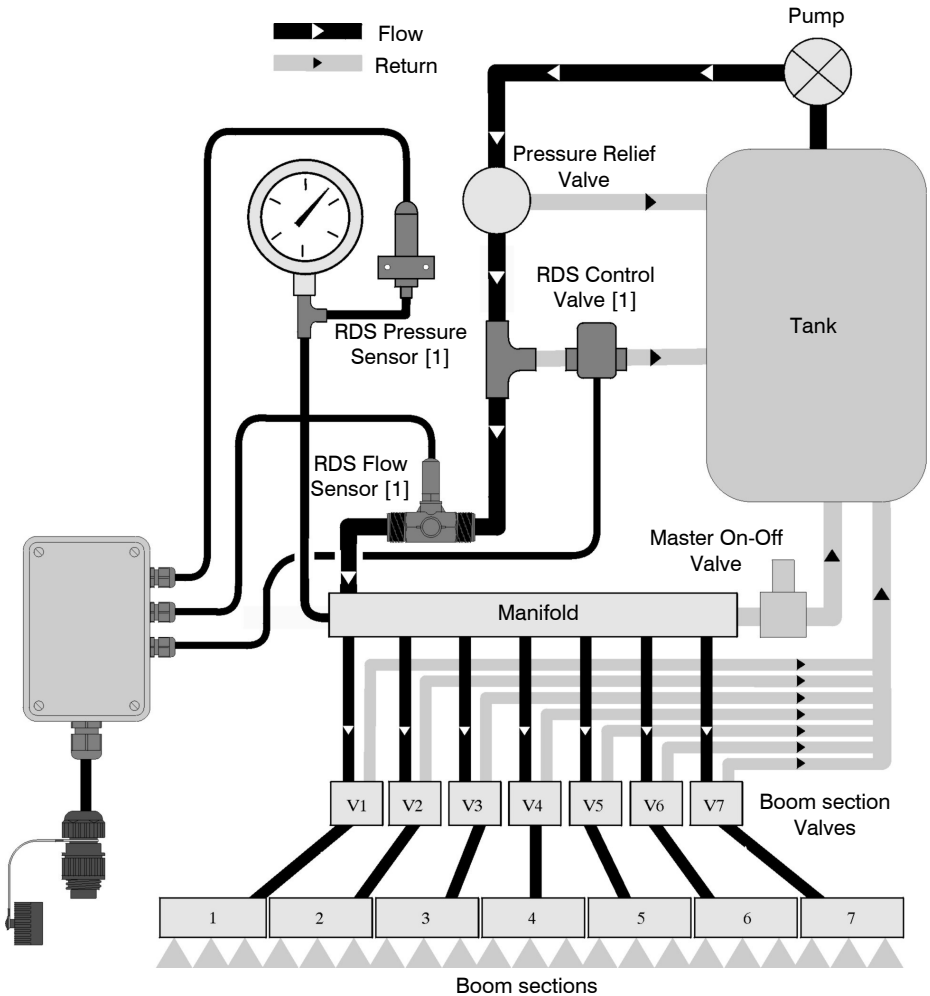

1.3 Terminator

Figure 3

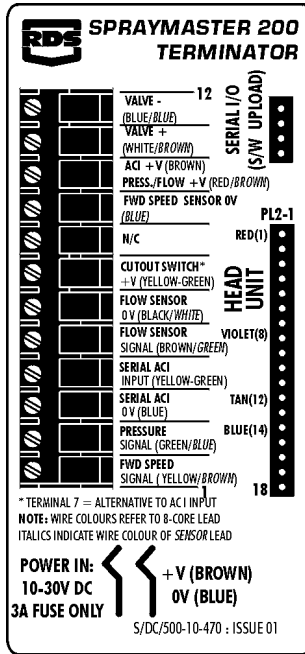

Additional information not covered by the individual kit instructions

The "Terminator" is the central junction box to which all other components are connected, including the power supply.

NOTE: *The Terminator is not sealed. It must be located where it will be protected from EXCESSIVE MOISTURE AND DIRT*

The Head Unit and Sensors operate satisfactorily over the voltage range 11-30V DC. Power is fed to the system via the Terminator.

Reverse Polarity and Power LED

The head unit has reverse polarity protection and therefore will not be damaged if you inadvertently have the power supply connections reversed. The LED on the Terminator PCB will not light when the 0V and +V connections are reversed. If after connecting the power supply, the instrument does not power up when you switch the ignition on, then:

- (a) check you have connected to a suitable point on the vehicle electrical system as described above.
- (b) If (a) is OK but the LED is not lit, check the polarity is correct.
- (c) If the LED is lit but the head unit does not come on, check the 18-way connector is properly connected (as per the wire colours marked on PCB).

Connecting the Head Unit Cable

Connect the IDC connectors as indicated on the Terminator label (fig. 3), and cable tie to the box to provide strain relief.

Connecting the other system components

Connect the other components as indicated on the Terminator label (fig. 3), and cable tie to the PCB to provide strain relief.

1.4 Cutout Switch/ACI

If fitting an ACI then please refer to the installation leaflet included in that kit.

Single section sprayers only require a simple on-off cutout switch. A range of cutout switch kits are available to suit any installation

Connect the cutout switch instead to terminal 7 (CUTOOUT SWITCH +V) and terminal 3 (SERIAL ACI 0V).

2. Calibration

2.1 Boom/Cutout Switch Setup

Boom configuration enables the instrument to automatically recognize the correct number of nozzles in use at any moment in time.

2.1.1 Enable Single Boom Configuration (Standard)

Cal Mode 3 ( + Power-up) - Channel 3: Setting = '[FuLL]', '1'

For the vast majority of sprayers, only a single boom configuration is needed, in which case set the following,

- (i) For single section sprayers fitted with a simple cutout switch, select "**FuLL**".
- (ii) If connecting an ACI module into the sprayer switchbox, (it recognizes up to 9 boom sections), select "**1**". You can then proceed to programme the number of nozzles and nozzle spacing for the individual sections.

2.1.2 Enable Multiple Boom Configuration

Cal Mode 3 ( + Power-up) - Channel 3: Setting = '2', '3', '4', '5'

This is a special feature primarily for vineyard sprayers, enabling you to programme up to 5 different boom configurations. The operator can then simply select an appropriate boom configuration for a particular crop stage.

Select '**2**', '**3**', '**4**', or '**5**'. You can then proceed to programme the number of nozzles and nozzle spacing for the individual boom sections, *for each of the boom configurations enabled*.

NOTE: *When 2 or more boom configurations are enabled, you will be prompted to select the boom at startup.*

2.1.3 Select Default Boom

Cal Mode 1 ( + Power-up) - Channel 3: Default = Channel disabled

This channel only appears if 2 or more boom configurations are set (see 2.1.2 above), and allows you to set the default boom.

NOTE: *You can also select the default boom during startup so you don't have to use this channel.*

2.1.4 Set No. of Nozzles per Section

Cal Mode 1 ( + Power-up) - Channel 6: Default = '0'

- (i) For single section sprayers fitted with a simple cutout switch, the number displayed is the total no. of nozzles for the boom.
- (ii) If connecting an ACI module into the sprayer switchbox, switch on one section at a time and then set the number of nozzles for that section. Repeat for each section in turn.

If none or more than one section is switched on, the display will show "1SEC" and you can't programme the no. of nozzles.

2.1.5 Nozzle Spacing

Cal Mode 1 ( + Power-up) - Channel 2: Default = '0.5 (m)'

Set the nozzle spacing as required.

2.2 Select Pressure or Flow-based Regulation

Cal Mode 2 ( + Power-up) - Channel 1: Default = 'Pres'

The Spraymaster can be configured as follows,

(i) Pressure sensor input only (default setting).

The display will simply show '**PrESS**'. A pressure gain setting of >0 (Cal 3, Channel 2) enables the pressure sensor input. Refer to section 2.2.2 for pressure sensor calibration.

NOTE: With the pressure sensor input enabled, you are prompted to select/adjust the nozzle type on normal startup.

(ii) Flow sensor input only (you can programme up to 6 configurations for different flow sensors).

The display will simply show '**turb**'. You can programme the instrument with up to 6 different flow sensor factors for sensors A to F. This is a not likely to be a common requirement and is intended for more specialist applications such as vineyard/orchard sprayers. A flow sensor factor of >0 set for one or more sensors A to F enables the flow sensor input.

NOTE: If more than one sensor factor is set >0, you are prompted to select/adjust the flow sensor on normal startup.

(iii) Pressure and flow sensor input.

If the pressure sensor gain is set >0, and one or more flow sensor factors are set >0, then you can select either '**PrESS**' or '**turb**' using the '+' and '-' keys.



NOTE: With both factors >0, you are prompted to select the regulation mode on normal startup.



2.3 Pressure-based Setup

Cal Mode 3 ( + Power-up) - Channel 2: Default (Gain) = '1.000'

The display will show '**GAIN**'.







2.3.1 Pressure Sensor Auto Calibration

1. Start with the engine running* but the PTO off.
2. Go to Cal. 3 channel 2.
3. Ensure pressure is actually at zero.
4. Hold the  button until beeps stop and 'zero' is displayed, followed by the milliamp signal from the sensor.
5. Press the  button, display shows '**PrES**', followed by the milliamp signal from the sensor.
6. Start the PTO and turn on the sprayer.
7. Use the '+' and '-' keys to set a typical sprayer pressure, e.g. 3 bar, – look at the external manual gauge for this, ignore the milliamp reading on the Spraymaster.
8. Press the  button. The display will briefly show '**PSI**' or '**bAr**' followed by the 'calculated' pressure.

9. Adjust the displayed pressure using the '+/-' buttons to make it agree with the external gauge reading.
10. Press the  button, the display will show '**done**' briefly, followed by '**GAIN**'.
11. The '**GAIN**' calibration factor can be viewed by pressing and holding the  button.

* The engine needs to be running because the instrument may re-boot and 'abort' the calibration routine during the voltage drop caused by starting.
Do-not carry out step '8' above until the pressure has been raised, otherwise the calibration routine will display '**Err1**' instead of '**done**' at step 10!



2.3.2 Manually adjust the Pressure Sensor Gain Factor

1. Press and hold the  key to change from '**GAIN**' to '**ZErO**'. The display shows '**ZErO**'.
2. Press and hold the  key until the display shows '0.0'.
3. Release the  key.
4. Press the  key to select '**GAIN**'.
5. Press and hold the  key to display the Gain value.
6. Adjust the factor using the '+' and '-' keys.
7. Release the  key when the Gain has been set.

2.3.3 Adjust Nozzle Flow Rate and Reference Pressure

Cal Mode 1 ( + Power-up) - Channel 4: Default - see table 1).

This channel allows you to set the default nozzle and set the correct nozzle flow rate for a given reference pressure following a jug test.

1. Press the '+' / '-' keys to select the appropriate nozzle. The display will show 'nn A' to 'nn I'
2. For the selected nozzle (A to I), press and hold the  key. After 5 seconds the default pressure is shown e.g. 'P3.00'. This is the reference pressure set for the jug test.
3. To adjust the reference pressure, continue holding the  key, and adjust the value using the '+' and '-' keys.
4. Release the  key to confirm the entry.

Press again within 5 seconds to display the flow rate e.g. 'Fx.xx'. This is the nozzle flow rate measured from the jug test.



5. To adjust the flow rate, continue holding the  key, and adjust the value using the '+' and '-' keys.
6. Release the  key to confirm the entry.

Table 1

Nozzle	Default Flow Rate (l/min @ 3 bar ref.)	User-defined nozzle description	User-defined	
			Flow Rate (l/min)	Reference Pressure (bar)
A	0.4			
B	0.6			
C	0.8			
D	1.0			
E	1.2			
F	1.6			
G	2.0			
H	2.4			
I	3.2			

NOTE: You can also select the default nozzle and adjust the flow rate during startup so you don't have to use this channel.

2.4 Flow-based Setup

2.4.1 Enable / Adjust Flow Sensor Cal Factor

Cal Mode 3 ( + Power-up) - Channel 4: Default - All factors zero).

To enable flow-based regulation, at least one cal factor must be set > 0.

1. Press the '+' / '-' keys to select the appropriate sensor.
2. For the selected sensor (A to F), simply press and hold the  key until the factor appears, and adjust the value using the '+' and '-' keys.

The nominal cal factors are as follows,

Turbine Size	pulse/litre	pulses/Imp gallon	pulses/US gallon
1/2"	3700	-	-
3/4"	1786	8119	6760
1"	650.0	2955	2460
1-1/2"	165.0	749.1	624.5
2"	100.0	454.6	378.5

These values will suffice until you do a jug test (please refer to the Operation Manual).

2.4.2 Select Default Flow Sensor

Cal Mode 1 ( + Power-up) - Channel 5: Default - Channel disabled (All factors set to zero).

If more than one sensor is enabled (i.e. the factor is >0), you can select which to make current. The operator is then prompted to select/adjust the flow sensor on normal startup.

For the selected sensor (A - F), simply press and hold the  key until the factor appears, and adjust the value using the '+' and '-' keys.

NOTE: You can also edit the cal factor for sensor A to F from here (as well as from Cal 3, Channel.4).

2.4.3 Set No. of Sensed Nozzles

Cal Mode 3 ( + Power-up) - Channel 5: Default =

This only needs to be set if an ACI and a flow sensor is installed.

Normally the sensed flow is for the full boom width, but in some installations for practical reasons, it may only be the flow to a particular boom section.

Programme the total number of nozzles on the boom section(s) to which liquid is delivered via the flow sensor.

You can set manually as follows. Press and hold the  key, and adjust the value using the '+' and '-' keys.

2.4.4 Valve Type

Cal Mode 3 ( + Power-up) - Channel 6: Default =

If each boom section valve when closed, simply shuts off the flow (e.g. solenoid valves), then set this channel to 'n' for a non-recirculating system.

If each boom section valve when closed, diverts the flow back to tank (e.g. Arag or Spray Systems rotary ball valves), then set this channel to 'r' for a recirculating system.

Press and hold the  key, and adjust the value using the '+' and '-' keys.

2.5 Control Valve Settings

2.5.1 Response Factor

Cal Mode 2 ( + Power-up) - Channel 2

The Response function sets the frequency at which the system adjusts the control valve when reacting to a change in forward speed. A lower setting results in a slower response, and increases the time taken for the application rate to match the target rate. A higher setting results in a faster response. If the application rate is unstable and varies about the target rate, then the response setting may be too high.

Press and hold the  key, and adjust the value using the '+' and '-' keys.

Default: Range: 0 - 9999

2.5.2 Minimum Pulse Width

Cal Mode 2 ( + Power-up) - Channel 3

This sets the minimum pulse length (milliseconds x 4) driving the flow control valve. The pulses becomes shorter as the application rate nears the target rate. A lower setting gives shorter pulses - too short and the flow rate may not change sufficiently. If the pulse is too long, the system may be unstable about the target rate.

Press and hold the  key, and adjust the value using the '+' and '-' keys.

Default: 4.0 (16 ms) Range: 0 - 9999

2.5.3 Deadband

Cal Mode 2 ( + Power-up) - Channel 4

The Deadband function sets the range over which the flow rate will vary about the target rate before the control valve will respond. A lower value will make the control respond to a smaller variation in flow and vice versa. If the value is too low the system may be unstable about the target rate.

Press and hold the  key, and adjust the value using the '+' and '-' keys.

Default: 2.0% Range: 0 - 99.9%

2.5.4 Startup Delay

Cal Mode 2 ( + Power-up) - Channel 5

If a spray boom is empty of liquid, the flow into it is rapid until it pressurises. The flow rate then reduces to the correct flow rate. Consequently the system takes some time to stabilise at the target rate. The instrument must be stopped from reacting to the initial flow surge.

Set the delay time to equal the time it takes for the sprayer system to reach normal working pressure. When the whole boom or individual section is switched on, the control valve will not operate for this time period.

Press and hold the  key, and adjust the value using the '+' and '-' keys.

Default: 2.0 seconds Range: 0 - 99.5 seconds

2.6 Speed Sensor Setup

Cal Mode 1 ( + Power-up) - Channel 1

In order to display the correct speed and accumulate distance correctly, the instrument must be programmed with the correct Speed Sensor Factor (SSF). This is the distance travelled between pulses received from the sensor.

The factory default setting is 2.000 m (78.78").

The S.S.F. can be calculated theoretically and then manually programmed, or the instrument can automatically calculate it via the "Autocal" function. Carry out the calibration whenever soil conditions or wheel sizes change.

NOTE: An 'Autocal' is simpler to perform and is more accurate in field conditions

2.6.1 'AutoCal'

For maximum accuracy, perform an auto-calibration in field conditions.

1. Set two markers at 100 metres apart (328 feet). Choose a convenient reference point on the tractor/implement and position this point opposite the first marker.
2. Press and hold the  key for 5 seconds to start the 'Autocal' routine.

The display will show 'Auto' for 5 seconds, and then show the number of received pulses.

3. Drive the vehicle until the chosen reference point on the tractor/implement is opposite the second marker.

The instrument counts and displays the sensor pulses received over the distance travelled.

4. Press the  key to end the autocal. The new factor is then displayed.

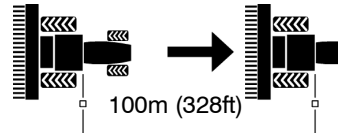

Autocal' distance

2.6.2 Manually calculating the Factor

The smaller the speed sensor factor the better the speed update will be. Aim for a factor less than 2.000 m (78.78").

NOTE: Perform the following calculations in inches or metres depending on whether the instrument is set for Imperial or Metric units. If you calculate the factor using any other unit of measurement e.g. feet or centimetres, the forward speed display will be incorrect.

- (i) **If a single magnet is installed (as with a standard RDS Propshaft Sensor kit)**, the distance travelled for each turn of the prop shaft must be determined. To determine this distance, drive the vehicle forwards for exactly **10** revolutions of the prop shaft. Measure this distance (in inches or metres) and divide by **10**, to find the Speed Sensor Factor.
 - (ii) **If 2 magnets are installed (as with a standard RDS Wheel Sensor kit)**, the distance is 1/2 the effective rolling circumference of the wheel. To determine this circumference, drive the vehicle forward in field conditions (with the implement attached if applicable), for exactly **10** revolutions of the sensed wheel. Measure this distance (in inches or metres) and divide by **20** to find the Speed Sensor Factor.
 - (iii) **If 4 wheel magnets are installed**, the distance is 1/4 the effective rolling circumference of the wheel. To determine this circumference, drive the vehicle forward in field conditions (with the implement attached if applicable), for exactly **10** revolutions of the sensed wheel. Measure this distance (metres) and divide by **40** to find the Speed Sensor Factor.
- Carry out this test whenever soil conditions or wheel sizes change.*
- (iv) **If an RDS Radar sensor is installed**, the Speed Sensor Factor is **0.008** m (or **0.312** inches).

If the calibration factor works out at over 2.000 m (78.78 inches), consider fitting additional magnets. Extra magnets are recommended if the vehicle has large diameter wheels or is slow-moving. In extreme circumstances you can find that the speed keeps going to zero as it times out before the next pulse arrives.

Number of Sensor magnets

The table gives the number of magnets required to enable a speed update of approximately once per second or faster on the display.

Tire diameter	Typical speed in normal operation:		
	up to 5mph (8km/hr)	6 to 9 mph (9 to 15 km/hr)	10mph (16 km/hr) or over
12" (0.3m)	1	1	1
24" (0.6m)	1	1	1
36" (0.9m)	2	2	1
48" (1.2m)	4	2	2
60" (1.5m)	4	4	2
72" (1.8m)	4	4	2

Example Calculation 1

The tractor is fitted with a single-magnet propshaft sensor. The measured distance for 10 rotations of the propshaft is 17'-6".

1. Convert the distance to inches :- $(17' \times 12") + 6" = 210"$
2. Divide by 10 (magnet pulses) to give the calibration factor:- $210" / 10 = 21"$
3. Programme the factor '021.0' as described overleaf.

Example Calculation 2

A vehicle with row crop wheels is fitted with 4 magnets. It is found to move 144 feet for 10 rotations of the sensed wheel.

Converting the distance to inches and dividing by 40 gives a calibration factor of $(144' \times 12") / 40 = \underline{43.2"}.$

Manually setting the Factor

With channel 1 selected, the existing speed factor is displayed. Press and hold the  key, and adjust the factor using the '+' and '-' keys.

2.7 Other Settings

2.7.1 Set Step % in Automatic Mode

Cal Mode 2 ( + Power-up) - Channel 6

In manual mode the '+' and '-' keys drive the valve directly. In automatic mode the target application rate is adjusted in % steps.

Set the % step here. Press and hold the  key, and adjust the factor using the '+' and '-' keys.

Default: 5%





2.7.2 Units

Cal Mode 3 ( + Power-up) - Channel 1 : Default = 'ME'

Press the '-' or '+' key to select 'Imp' for Imperial Units.

Units	Metric	Imperial
Forward Speed	km/hr	miles/hr
Area	hectares	acres
Volume	litres	gallons
Pressure	bar	p.s.i.
Flow Rate	litres/min	gallons/min
Application Rate	litres/hectare	gallons/acre

Functions summary

Mode	Ch.1	Ch.2	Ch.3	Ch.4	Ch.5	Ch.6
Normal Display	View Fwd Speed	View Part /Total Area	Part / Total Volume	View Liquid Pressure	View Full Boom Flow	Application Rate
+ Adjust 	Set Sim. Speed	/Total Area	Volume Cal. adjust		View Nozzle Flow Rate	
Hold 	View nozzles					
Cal 1  and power up	View/Edit Speed Cal. Factor Start Autocal	Set Nozzle Spacing	Select Boom	Nozzle Wizard	Select Flow Sensor	Set No. of Nozzles per sectionr
Cal 2  and power up	Select Pressure /Flow-based Regulation	Set Valve Response Factor-	Set Valve Minimum Pulse	Set Valve Deadband	Set Valve Regulating Delay	Set AUTO rate - Step %
Cal 3  and power up	Select Metric /Imperial Units	Pressure Sensor Calibration-	Set No. of Booms-	View/Edit Flow Sensor Factor-	Set No. of Sensed Nozzles-	Select Return/Non-return Flow measurement-
		AUTO Set Zero Set Press	MAN Set Zero Set Gain			

Issue 1: 24/1/05 Original
Issue 1b: 1/2/05 ref. p.3, 4, 6 : S/AC/327-1-091 now separate parts:-
S/AC/327-1-008 + S/CB/327-17-010
Issue 1c 23/5/05 Revised section 2.3.1
Issue 1d 3/3/06 Parts list revision: p.3, 4
Issue 1e 7/4/06 2.7.2 - correction