



**Bale Wrapper Controller  
(All RA/TW models)  
Technician Level Settings**

RDS Part No.:	S/DC/500-10-447
Document Issue:	1: 10/12/03
Software Issue:	EX 301-023

## Electromagnetic Compatibility (EMC)



This product complies with Council Directive 89/336/EEC when installed and used in accordance with the relevant instructions.

Our policy is one of continuous improvement and the information in this document is subject to change without notice. Check that the software reference matches that displayed by the instrument.

© Copyright RDS Technology LTD 2003

\\UK447-1.DOC

## Service and Technical Support

PLEASE CONTACT YOUR NEAREST TANCO DEALER OR TANCO

Tanco Autowrap Ltd

Bagenalstown

Co. Carlow

Ireland

Tel: +353 (0)503 21336

Fax: +353 (0)503 21737

e-mail: [info@tanco.ie](mailto:info@tanco.ie)

web: [www.tanco.ie](http://www.tanco.ie)

## Contents

<b>CONTENTS</b>	<b>2</b>
<b>1. The Technician Setup menu</b>	<b>3</b>
<b>1.1 Diagnostic Mode</b>	<b>3</b>
Inputs	3
Outputs	4
<b>2. Table Wrapper (TW) Operating Sequence</b>	<b>5</b>
<b>3. Table Wrapper (TW) Default Programmable Factors</b>	<b>6</b>
<b>4. Rotating Arm Wrapper (RA) Operating Sequence</b>	<b>7</b>
<b>5. Rotating Arm Wrapper (RA) Default Programmable Factors</b>	<b>8</b>

## 1. The Technician Setup menu

The 'Technician Setup' menu is not normally accessible to the operator and requires a PIN access code. The factory default code is 1234.

Use the 4-way switch to navigate the menu. Each menu screen indicates which keys to press to make the settings. The instrument will default back to the main operating display after 30 seconds if no other key is pressed

Here is the tree showing access to the Setup menu;

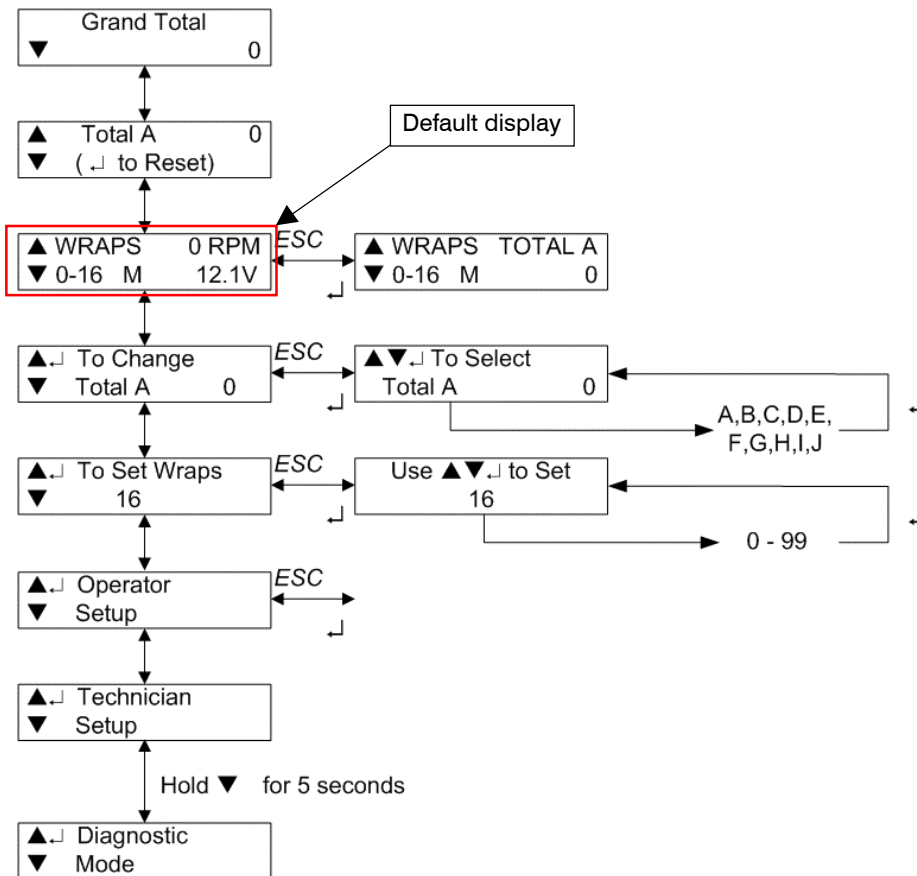

### 1.1 Diagnostic Mode

Switch the instrument on, then press and hold the ▼ key for 5 seconds to enter the diagnostic mode.

#### Inputs

The display then shows the status of the inputs. A ◀ pointing to an input number indicates that the input is working e.g. when the table sensor is closed an arrow will appear pointing to 1 on the display to confirm that the input is working correctly.



The input functions as follows:

Input	Function		J/Box Head unit lead	
	Table-type Wrapper	Rotating arm-type Wrapper	AMP Pin No.	Wire colour
1	Table sensor	Rotate sensor	21	White/Green
2	Film sensor	Film sensor	20	Green/Red
3	Load Arm sensor	Emergency Stop	23	Yellow/Blue
4	Not utilised	Not utilised	-	-
5	Tip sensor	Squeeze Pr. Switch	24	Red/Blue
6	Safety input	Safety input	22	Orange/Green

### Outputs

From the input status screen, press the ENTER key to select the output test mode.

Now use the keypad to test the outputs 1 to 10, e.g. pressing switch 1 powers the Load Up Solenoid. A ◀ pointing to an output number indicates that the output is switched on.

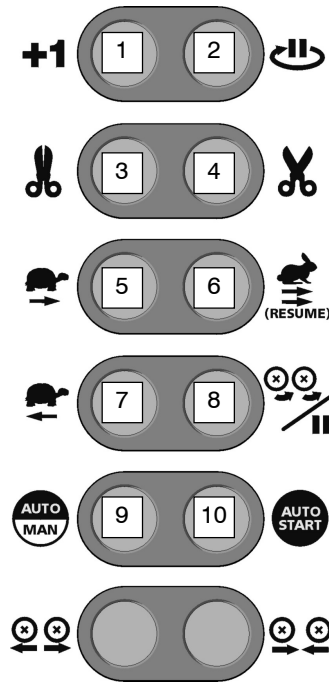

Output No.	Output function		J/Box Head unit lead	
	Table-type wrappers	Rotating-arm-type wrappers	AMP Pin No.	Wire colour
1	Load Up	Rollers In	3	White
2	Load Down	Rollers Out	2	Green
3	Fast Speed	Fast Speed	1	Blue
4	Forward Rotate	Forward Rotate	4	Orange
5	Reverse Rotate	Close Ctr Valve	5	Grey
6	C & S Open	C & S Open	7	Red
7	C & S Close	C & S Close	6	Black
8	Tip Down	Max Squeeze Valve	8	Yellow
9	Tip Up	Master Valve	9	Pink
10	System Pressure	Double Drive	13	Red/Black

Press the ENTER key a second time to select outputs 11 to 13 to test in the same way:

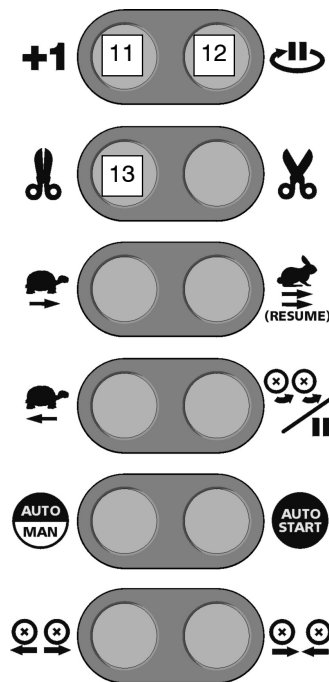

Output No.	Output function		J/Box Head unit lead	
	Table-type wrappers	Rotating-arm-type wrappers	AMP Pin No.	Wire colour
11	Beacon	Reversing	11	Brown
12	Squeeze In	Rollers Stop	12	White/Blue
13	Squeeze Out	Rotation after Wrap	10	Violet
14	Not utilised			
15				
16				
17				
18				
19				
20				

## 2. Table Wrapper (TW) Operating Sequence

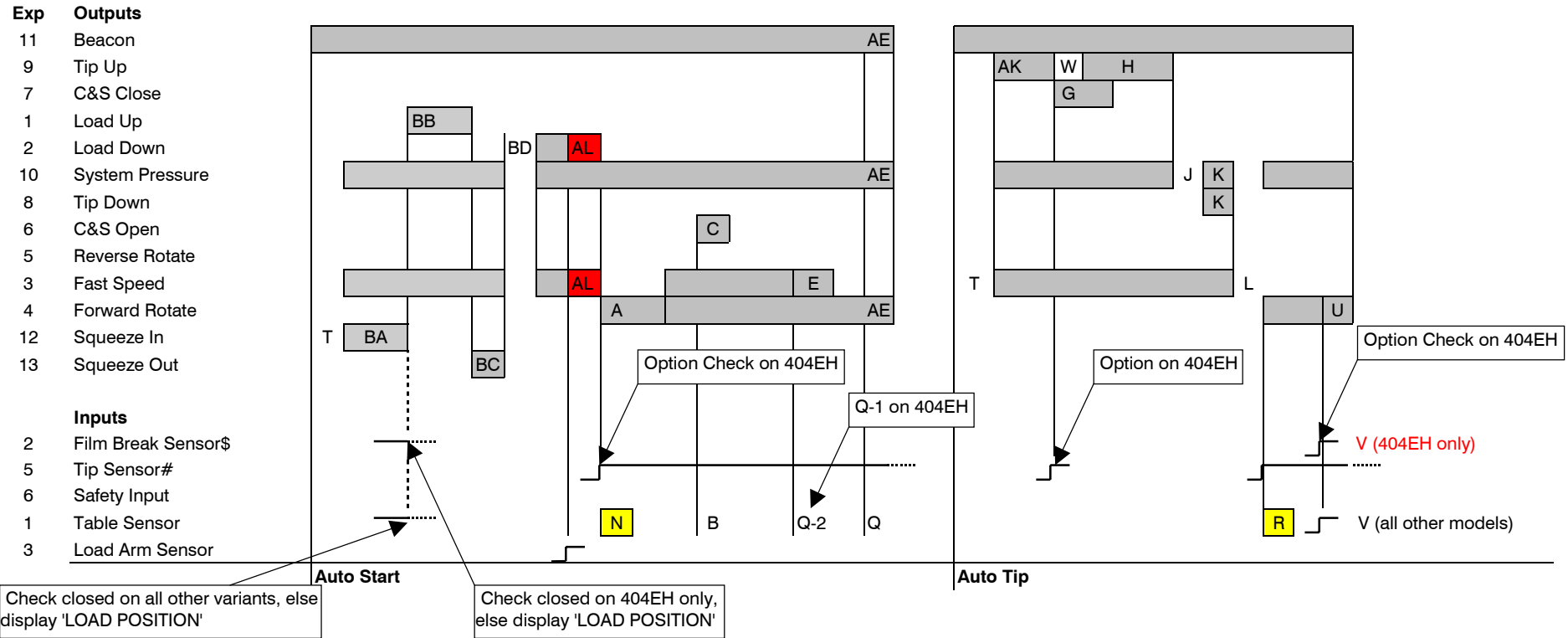

1. Film Break sensing works as follows. Input 2 senses rotation on the film roll. When pulses are detected, film is being applied correctly. If the pulse stream stops for >1 second the display should show FILM BREAK and the alarm should sound. At this point, wrapping will stop. Resuming wrapping at the point where it stopped is possible using the fast rotate switch. This feature should only be enabled when the normal rotation speed is > 15 RPM. This feature is disabled when the target number of wraps has been reached.
2. If the load arm sensor opens during wrapping, the load up function should be inhibited.
3. Resume possible after emergency stop by pressing fast wrap.
4. Enhance diagnostic capabilities. Input check remains as is, checking inputs 1-6. Outputs 1-20 are checked as follows; switches L1,R1..L5,R5 switch O/P'S 1-10 respectively. Press ENT again to access second batch of 10 outputs. In this case, Switches L1,R1..L5,R5 switch O/P'S 11-20 respectively. In each case, the status of the output is displayed eg: ON- OK; ON-Open Cct; ON-Short Cct. (This applies to TW and RA machines).
- #. Optionally, Tip sensor is not used as such on 404EH programme, hence delay AK. Sensor is now used to confirm that table is Horizontal before wrapping. See above. If sensor opens during wrapping. Stop rotation and display 'TIP DOWN!' Delay AK must be >0 for this to function. If AK=0 then Tip sensor is used conventionally.

**3. Table Wrapper (TW) Default Programmable Factors**

<b>Programmable Factors</b>											
<b>Factor</b>	<b>Sequence</b>	<b>580A /1080A +1/4t (Default Seq.)</b>	<b>404EH</b>	<b>280ARC+ 1/4t</b>	<b>580A/ 1080A</b>	<b>280ARC</b>	<b>580A Auto Load</b>	<b>1080A Auto Load</b>	<b>Range</b>	<b>Resolution</b>	<b>Notes</b>
<b>A</b>	Slow Start Duration	2.0	2.0	2.0	2.0	2.0	2.0	2.0	0-9.9	0.1	
<b>C</b>	C&S Open Duration	2.5	2.5	2.5	2.5	2.5	2.5	2.5	0-9.9	0.1	
<b>G</b>	C&S Close Duration	1.5	2.0	1.5	1.5	1.5	1.5	1.5	0-9.9	0.1	
<b>L</b>	Tip down to 1/4 rev delay	0.3	0.3	0.3	0.0	0.0	0.0	0.0	0-9.9	0.1	
<b>N</b>	No pulse detected (Wrap)	0.8	0.8	0.8	0.8	0.8	0.8	0.8	0-9.9	0.1	
<b>R</b>	No pulse detected (1/4 Rev)	0.8	0.8	0.8	0.0	0.0	0.0	0.0	0-9.9	0.1	
<b>F</b>	Delay to stop after last pulse (Wrap)	0.0	0.0	0.0	0.0	0.0	0.0	0.0	0-9.9	0.1	
<b>U</b>	Delay to stop after last pulse (1/4 rev)	0.0	0.0	0.0	0.0	0.0	0.0	0.0	0-9.9	0.1	
<b>W</b>	Tip pause delay	1.5	2.0	1.5	1.5	1.5	1.5	1.5	0-9.9	0.1	
<b>AK</b>	Tip to C&S close Duration		2.0						0-9.9	0.1	
<b>B</b>	Pulses to C&S open	4	2	4	4	4	4	4	0-9	1 Pulse	
	Check Snr before Tip		YES						Yes/No	N/A	
	Check Snr before Load		YES						Yes/No	N/A	
<b>Z</b>	Table over-speed alarm	26	26	26	26	26	26	26	0-99	1Wrap	
<b>Non-programmable Factors</b>											
<b>T</b>	Beacon Delay	0.0	0.0	3.0	0.0	3.0	0.0	0.0			
<b>V</b>	Pulses after Q to Stop Position	1	1	1	0	0	1	1			
<b>Q</b>	Pulses per target number of wraps	Targ x 2-1	Targ #	Targ x 2-1	Targ x 2	Targ x 2	Targ x 2-1	Targ x 2-1			

#### 4. Rotating Arm Wrapper (RA) Operating Sequence

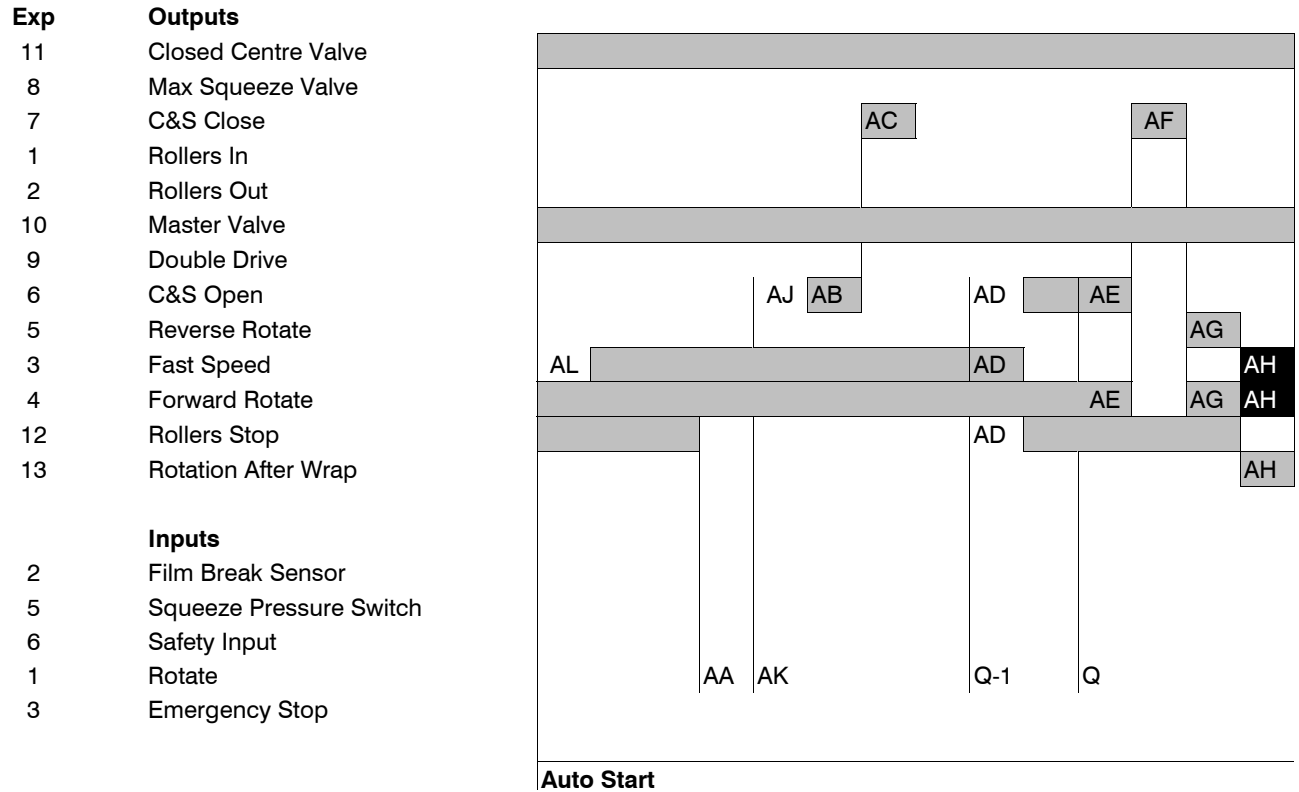

1. Operation of the film break sensing to be defined.
2. Resume possible after emergency stop by pressing fast wrap.

**AH** 1300 model only

### 5. Rotating Arm Wrapper (RA) Default Programmable Factors

Programmable Factors									
Factor	Sequence	1300	1510	1514	1510T	1514T	Range	Resolution	Notes
AA	Stop Bale Rotation	0	0	4	4	4	0-9	1 Pulse	
AL	Slow Start Duration	3.0	3.0	3.0	3.0	3.0	0-9.9	0.1	
AK	Wraps until Film Release	2	2	2	4	2	0-9	1 Pulse	
AJ	Delay after AK to Film Release	0.5	0.5	0.5	0.0	0.0	0-9.9	0.1	
AB	C&S Open Duration	0.4	0.4	0.4	0.3	0.3	0-9.9	0.1	
AC	C&S Close Duration	3.0	3.0	3.0	3.0	3.0	0-9.9	0.1	
AF	C&S Close Duration	2.0	2.0	2.0	2.0	2.0	0-9.9	0.1	
AG	Reverse Duration	0.0	0.0	0.0	1.5	1.5	0-9.9	0.1	
	Index Enable	OFF					ON/OFF		